

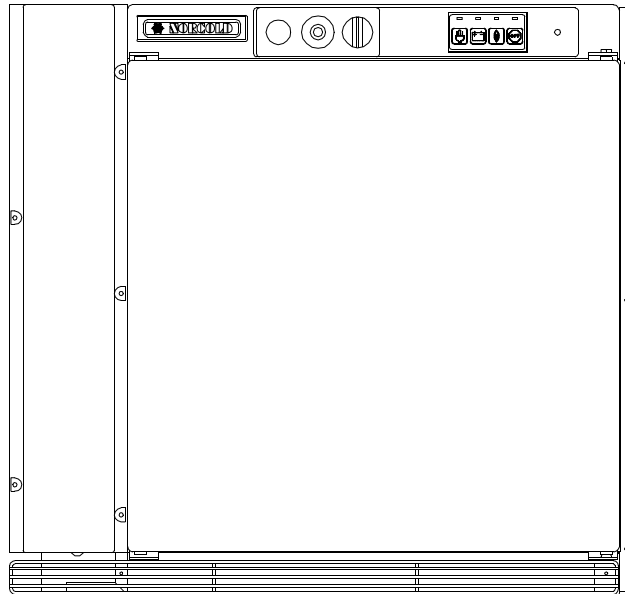

# Service Manual

## Model 3163



### Contents

Important Safety Information . . . . .	1	No Spark at Burner . . . . .	12-13
Specifications . . . . .	2	Burner Ignites But Flame Will Not Hold . .	14-15
General Information . . . . .	2	Trouble Shooting - Ventilation Fan . . . .	16-17
Direct Vent Requirements . . . . .	2	Diagnosing Cooling Problems . . . . .	18
Propane System . . . . .	4	Refrigerator Removal & Re-Installation Procedure (EuroVan Camper) . . . . .	19
Description of Controls . . . . .	5	Refrigerator Removal & Re-Installation Procedure (Rialta) . . . . .	20
Lighting and Start-Up Instructions . . . . .	6	Wiring Pictorial & Diagram . . . . .	21
Limited Warranty Time Allowance Chart . . . .	7	Parts List & Exploded Views . . . . .	22-27
Refrigerator Will Not Operate on AC . . . . .	8-9		
Refrigerator Will Not Operate on DC . . . .	10-11		

## Important Safety Information

### **WARNING**

Read this information before attempting to perform service on this refrigerator.

Page 8 shows a wiring pictorial and diagram. Review both the wiring pictorial and diagram to understand the electrical circuits and the relationship to the individual components.

Understand the service procedures before performing the service.

Always apply the safety precautions listed below when servicing this refrigerator. Failure to follow these safety precautions can result in substantial property damage, severe personal injury, or death.

- Hazardous voltage can cause property damage, severe personal injury, or death. Disconnect both the AC and DC electrical sources to the refrigerator before performing service.
- To prevent short circuits, connect the positive battery lead to the refrigerator before attaching the negative lead.
- The 120 VAC circuit must be properly grounded. Never cut or remove the round grounding prong from the refrigerator's AC power cord. Do not use a two-prong adapter. Do not use an extension cord.
- The use of improper rated fuses can lead to an electrical fire. In the event of a circuit overload, replace blown fuses with a fuse specified by Norcold. Fuse specifications are found in the "Specifications" section on page 2 of this manual. The correct fuse size is printed adjacent to the fuse on the refrigerator.
- Keep liquids away from electrical connections. Many liquids are electrically conductive and could cause serious arcing damage and, in some cases, fires.
- Never bend, drop, drill, weld, or hammer the cooling unit. Doing so can cause the cooling unit to rupture, releasing chemicals under high pressure. Contact with these chemicals may cause severe burns to the eyes or skin.
- Never attempt to repair or recharge the cooling unit. A defective cooling unit must be replaced.
- Hazardous vapors. Propane gas can cause an explosion, resulting in property damage, severe personal injury, or death. Use caution when working with or near a propane gas system. Do not smoke. Do not create sparks or use an open flame to check gas supply lines or gas connections.
- To prevent gas leaks and damage to the gas supply lines and fittings, use two wrenches when connecting or disconnecting gas fittings (See Figure 1 below).

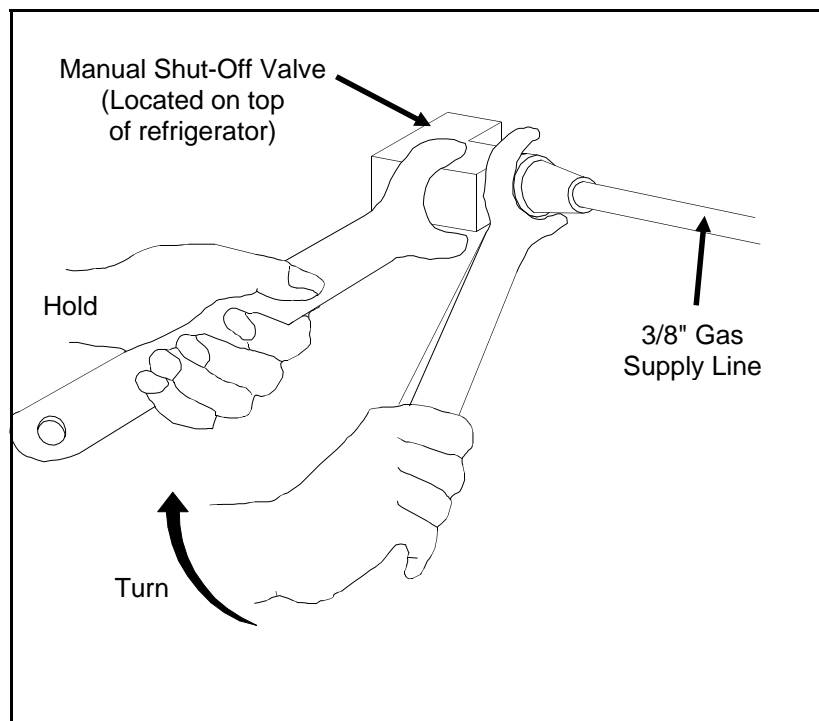

Figure 1 - Double-Wrenching Gas Fittings

# Specifications

## Operating Limits

AC Mode: 132 volts AC max. - 108 volts AC min.  
DC Mode: 15.4 volts DC max. - 11.5 volts DC min.  
Gas Mode: 11" W.C. max. - 10.5" W.C. min.  
15.4 VDC max. - 10.5 VDC min.

## Current Draws

AC Heating Element - 1.3 amp @ 110 volts AC  
1.4 amps @ 120 volts AC  
DC Heating Element - 11.7 amps @ 12 volts DC  
13.6 amps @ 14 volts DC  
Ignition Relighter - 150 milliamps during ignition  
100 milliamps steady state  
Ventilation Fan - 240 milliamps

## Ratings

LP Gas Mode: 640 BTU/Hr. Input  
11" W.C. Gas Supply  
.010" Orifice (LP10)  
AC Mode: 110 volts AC - 140 watts  
DC Mode: 12 volts DC - 140 watts

## Fuse Replacement Data

AC Circuit: 3 amp Type 3AG (1/4" x 1/4")  
Norcold Part No.: 61654622  
DC Circuit: 20 amp Type 3AG (1/4" x 1/4")  
Norcold Part No.: 61440522  
Gas Circuit: 1 amp Type 3AG (1/4" x 1/4")  
Norcold Part No.: 618079

## General Information

### **WARNING**

*This refrigerator is not intended to be operated as a Free-Standing refrigerator (i.e. the products of combustion must be completely isolated from the living area) or installed in such a way as to conflict with these installation instructions. Unapproved installations could result in safety risks or performance problems.*

The model 3163 is designed for built-in installation and operates on propane gas, 120 volts AC, or 12 volts DC.

The propane gas mode of operation is that of a sealed combustion unit. A sealed combustion installation utilizes a single fresh vent-air intake/exhaust assembly to supply fresh air to the burner and to remove the products of combustion. This insures the products of combustion are isolated from the living area of the vehicle. The vent-air intake/exhaust assembly is routed through the vehicle's outside wall and is connected to the refrigerator's burner assembly and exhaust flue tube by flexible piping. The vent-air intake/exhaust assembly used for this installation has been certified for this refrigerator and must not be modified.

## Direct Vent Requirements

### Interior Ventilation

The refrigerator's cooling system requires a continual air flow to maintain proper refrigeration. An inlet and exhaust vent is required to insure adequate air flow. The refrigerator is equipped with an inlet vent located at the bottom front of the refrigerator. The installer is required to provide the exhaust vent. The exhaust vent must have a cross sectional area of 30 square inches minimum. The exhaust vent is to be installed above the top surface of the refrigerator so as not to trap hot air generated by the cooling unit. The refrigerator is equipped with a DC ventilation fan to assist the air flow across the refrigerator's cooling system while operating the refrigerator in the Gas mode.

### Ventilation Fan

A thermostat controlled mechanical fan is used to move air across the refrigerator's cooling system. The

thermostat is calibrated to activate the fan whenever the vehicle's interior temperature reaches 85 degrees or higher.

When leaving the vehicle unattended, it is advisable to leave windows or roof exhaust vents open to maintain the vehicle's interior temperature below 85 degrees. This will allow the refrigerator to operate efficiently, minimize fan operation, and limit current draw from the battery.

### Installing the Vent-Air Intake/Exhaust Assy

### **WARNING**

*Improper location and installation can cause injury or property damage. This refrigerator and it's vents are design certified by the American Gas Association and the Canadian Gas Association. Any deviation or sub-*

stitution will void the agencies' certifications and the Norcold warranty. Refer to this manual for proper instructions. Install the refrigerator and vents as directed by Norcold without modification.

The clearance from the refrigerator's left side (facing the front of the refrigerator) to the vehicle's exterior wall is important. This is the area in which the inlet and outlet flexible piping will be connected to the vent terminal housing during installation. Refer to Figures 3 and 4 for maximum clearances from refrigerator cabinet to vehicle exterior wall.

The wall thickness the vent terminal housing will accommodate is .030" minimum to 1.250" maximum. Figure 2 illustrates the configuration of the opening for the vent terminal housing. Do not make the opening in the vehicle wall larger than required. The clearance should be enough for the terminal housing to pass through the opening. If the opening is too large, the outer gasket will not cover the vent housing opening.

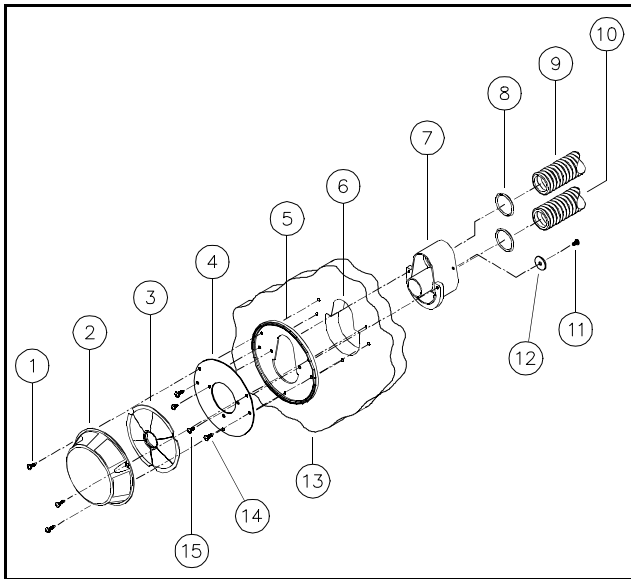

Figure 2 - Air Intake/Exhaust Assembly

- |                                  |                           |
|----------------------------------|---------------------------|
| 1. Mounting Screw                | 8. O Rings                |
| 2. Vent Cover                    | 9. Intake Piping          |
| 3. Outer Disk                    | 10. Exhaust Piping        |
| 4. Inner Disk                    | 11. Locking Washer Screw  |
| 5. Rubber Gasket                 | 12. Locking Washer        |
| 6. Vent Terminal Housing Cut-Out | 13. Vehicle Exterior Wall |
| 7. Vent Terminal Housing         | 14. Mounting Screw        |
|                                  | 15. Mounting Screw        |

It is imperative that the wall opening for the vent terminal housing not be too low. The flexible piping (inlet and outlet pipes) must rise from the refrigerator to the terminal housing. There are two specific vent-air intake assembly kits available to accommodate most installations. Figures 3 and 4 illustrate two installations with the maximum flexible piping lengths and the vent terminal housing locations.

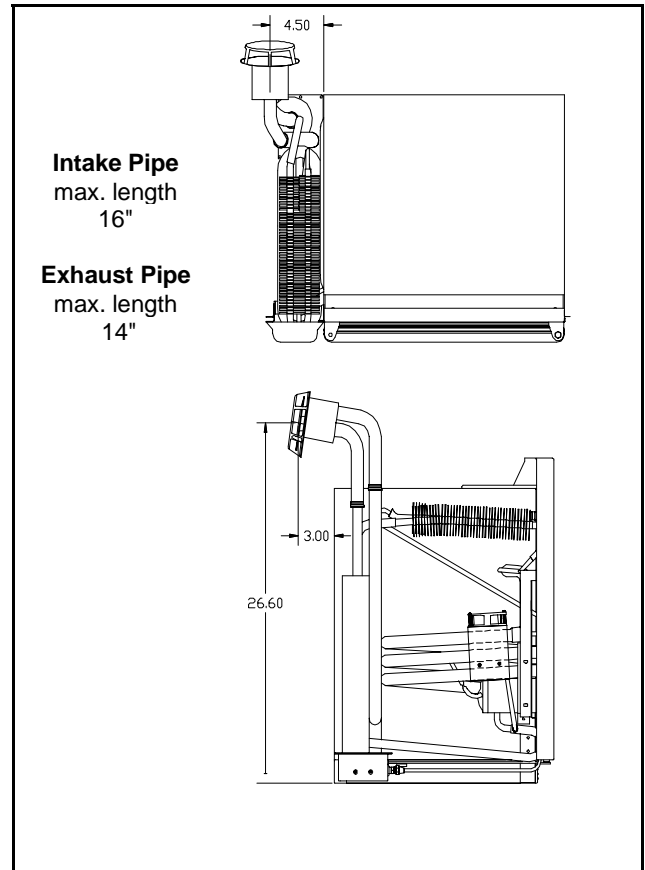

Figure 3 - Kit #617941 Flexible Piping & Vent Location

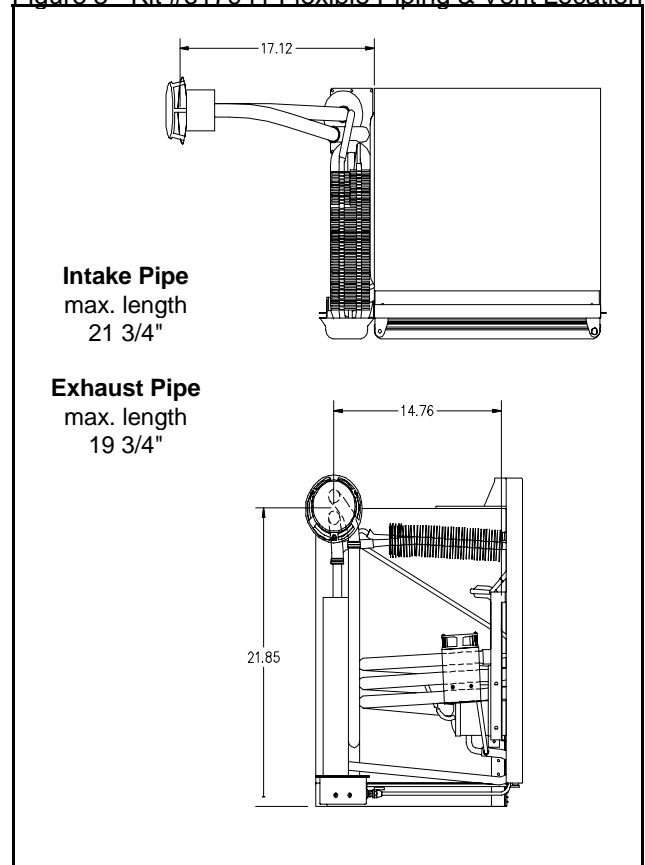

Figure 4 - Kit #617943 Flexible Piping & Vent Location

## Insulating the Flexible Exhaust Piping

The flexible exhaust pipe must be insulated prior to installation into the vent terminal housing. The flexible exhaust pipe connects to the flue tube of the refrigerator's cooling unit and routes to the bottom opening of the vent terminal housing. Use the non-combustible insulation material supplied with the vent-air intake/exhaust kit. Do not insulate the Air Intake pipe.

## Installing Refrigerator into the Enclosure

Set the refrigerator into the enclosure and slide it back enough to connect the gas supply piping to the manual shut-off valve located at the top of the refrigerator. Connect the 12 volt DC supply to the terminal block also located at the top of the refrigerator. Connect the AC

power cord to the receptacle. Place the "O" rings onto the ends of both flexible pipes. Bend the flexible pipes so they clear the top of the enclosure. Connect the piping as follows:

**Exhaust Pipe** - This pipe is insulated and connects to the flue tube of the cooling unit. Route and connect to the bottom opening of the vent terminal housing.

**Intake Pipe** - This pipe is not insulated and connects to the burner cover. Route and connect to the top opening of the vent terminal housing.

Secure both flexible pipes to vent terminal housing with locking washer and screw. Slide refrigerator completely into enclosure.

## Propane System

### Testing of the Vehicle's Gas Supply Piping

When installation is complete, the propane gas supply piping must be inspected and tested for leaks from the refrigerator to the main gas supply tank. Use a leak detection solution. Do not test for leaks with an open flame.

If compressed air is used for leak testing, the pressure must not exceed 1/2 psig (14 inches water column).

The appliance and its individual shutoff valve must be disconnected from the gas supply piping system during any pressure testing of that system at test pressure in excess of 1/2 psig (14 inches water column).

The appliance must be isolated from the gas supply piping system by closing its manual shutoff valve during any pressure testing of the gas supply piping system at test pressure less than or equal to 1/2 psig (14 inches water column).

Check the gas pressure to the refrigerator without other gas appliances operating. The pressure should not exceed 11 inches water column. With other appliances operating the pressure should not be less than 10.5 inches water column.

### Gas Burner Flame

The gas operation of the refrigerator is controlled by the correct burner flame which supplies the heat input to the refrigerator's cooling system. The correct burner flame is dependent upon correct input gas pressure and the burner and burner orifice being clean. The propane gas piping and the supply pressure must be inspected and tested at least twice a year. All inspections and tests must be performed by the propane gas supplier or a qualified service agency.

A visual check of the burner flame should be made regularly. The burner flame can be observed through the air inlet grille as shown in Figure 5.

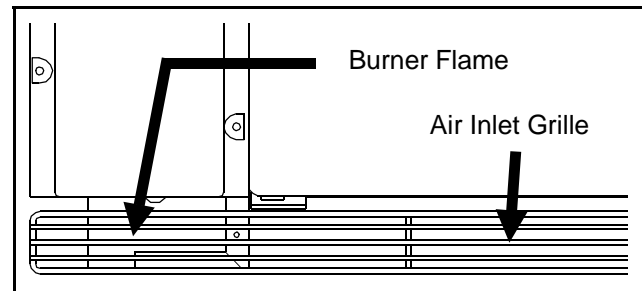

Figure 5

As illustrated in Figure 6, the flame should be sharp blue with a stable burning appearance. If there is a constant yellow component observed or if the flame appears erratic and unstable, perform the following inspection. Check the gas supply pressure to insure the pressure is between 10.5" W.C. min. - 11" W.C. max.. Inspect the Air Intake pipe between the burner and the vent terminal housing for obstructions. If the gas supply pressure is within specifications, and the Air Intake pipe is clear of obstructions, clean the burner, orifice, and cooling unit's flue tube. Also observe the position of the flame; it must be centered under the flue tube without touching the inner wall of the tube.

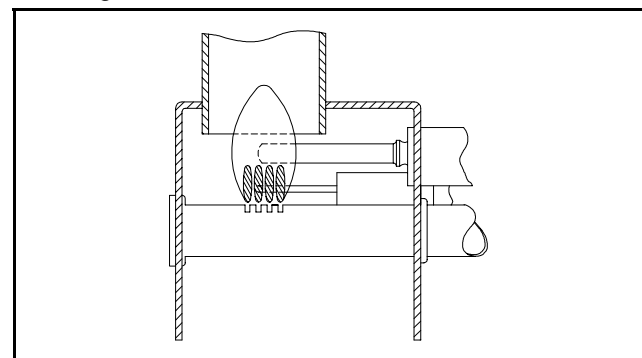

Figure 6

## Check Out of Flame Failure Safety Device

1. To verify operation of the flame failure safety device, start the refrigerator in the gas mode (refer to lighting instructions on page 6) and verify the presence of a flame.
2. Turn off the gas at the manual shut-off valve or at the main gas supply tank.
3. The flame will go out and within 3 minutes the flame safety device will automatically close (an audible click will be heard as this device closes).
4. Turn the gas on at the manual shut-off valve.
5. Attempt to light the burner by placing the mode selection button to the gas mode. Do not push in the safety valve.
6. Without holding the safety valve in, the burner flame will not re-light. This indicates the flame failure safety device is functioning.

## Description of Controls

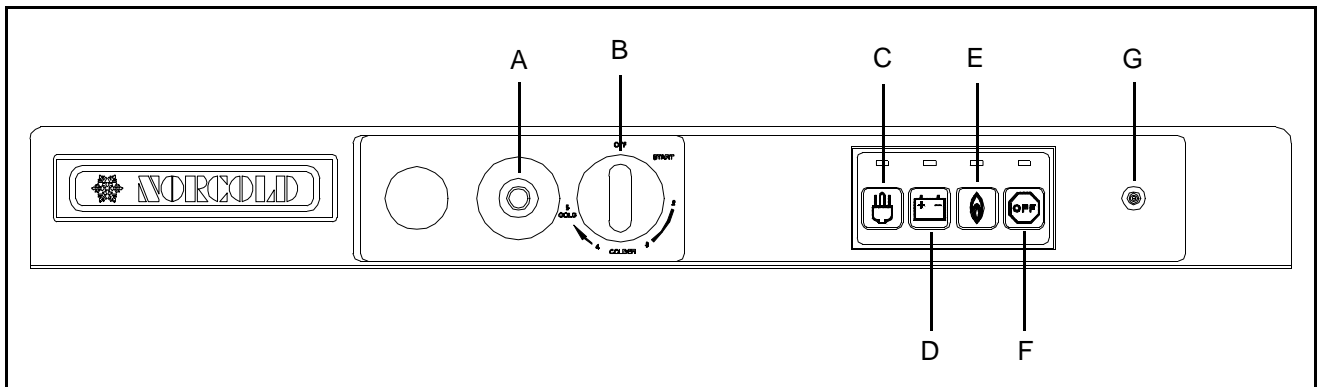

Figure 7

The refrigerator's operating controls are located on top of the refrigerator. The control panel is located on the top front surface directly above the refrigerator door.

### (A) Safety Valve

The safety valve is designed so that any loss of flame will stop the gas flow to the burner. It is controlled by means of a thermocouple that is positioned in the flame. As long as a flame is detected by the thermocouple, the valve will remain open. Upon flame failure, the valve closes, shutting off the gas flow to the burner. During the gas ignition process, the safety valve button must be held in until a flame is established at the burner.

### (B) Thermostat

The thermostat on the Norcold refrigerator controls both the gas and AC electric operations, *thereby eliminating the necessity of resetting each time a different power source is selected.* Rotate the thermostat knob clockwise to make the refrigerator cabinet colder.

### (C) 120 Volts AC Operation

Pressing button (C) selects the AC mode of operation. When the AC mode is selected and AC voltage is supplied to the refrigerator, the refrigerator will operate on 120 volts AC.

### (D) 12 Volts DC Operation

Pressing button (D) selects the DC mode of operation. When DC is selected and DC is available to the refrigerator, the refrigerator will operate at full cooling power. The DC operation is a continuous run (no thermostat control) mode.

### (E) Gas Operation

Pressing button (E) selects the Gas mode of operation. The refrigerator is equipped with electronic ignition. When the gas mode is selected, the electronic ignition is energized and sparking is generated at the burner (Note: Push safety valve button in and hold until flame is present at burner). Sparking will continue until a flame is present at the burner. When a flame is sensed by the electronic ignition module, the sparking ceases and the flame indicator (G) illuminates indicating the refrigerator is operating on gas.

### (F) Off

Pressing button (F) will interrupt all power sources and cease operation of the refrigerator.

## Lighting and Start-Up Instructions

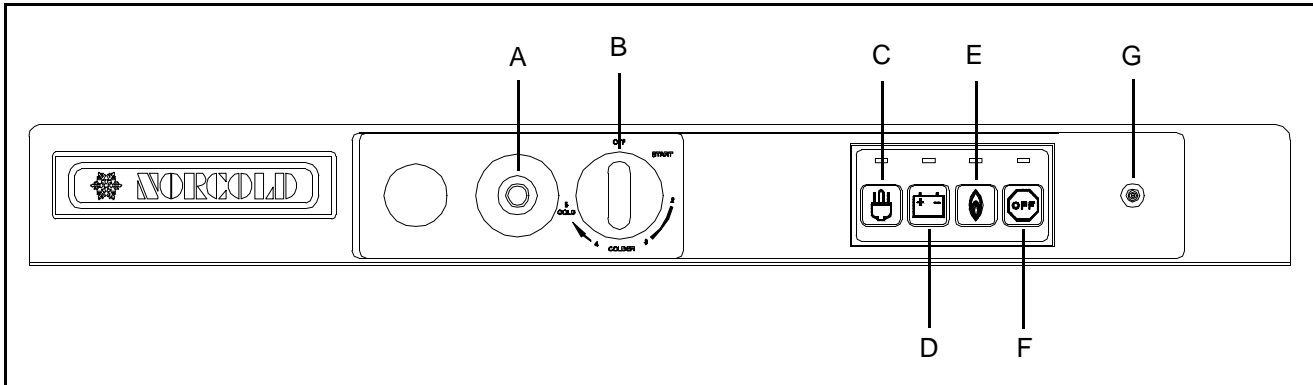

Figure 8

The Lighting and Start-Up Instructions are located on the top portion of the interior door liner.

Refer to Figure 8 for location of the operating controls.

**Notice:** When warm humid weather conditions are observed, operate the refrigerator on either AC or DC electric for a minimum of five (5) minutes before attempting to follow the Start-Up Instructions for Gas operation.

### AC Operation

1. Press mode selection button (C).
2. Set the thermostat (B) to the coldest (maximum) setting. Allow to operate at maximum setting for 6 to 8 hours before setting to mid range.

### DC Operation

1. Press mode selection button (D). There is no need to set thermostat to any setting. The DC operation is a continuous run (no thermostat control) mode.

### Gas Operation

1. Set thermostat (B) to the start setting.
2. Press mode selector button (E). Ignition spark will be present at the burner.

3. Push and hold the safety valve button (A) until the indicator lamp (G) glows steady. Continue to hold the safety valve button in for 15 seconds and then release. The indicator lamp should remain a steady glow. If the lamp turns off, repeat this step.

**Notice:** On initial start-up, it may take longer for the burner to light because of air being purged from the gas supply line.

## WARNING

*Do not hold gas valve in more than 30 seconds. If the flame is not indicated within this time, press selector switch (F), wait 2 minutes, and retry. Continuing to hold the gas valve in will cause gas to build up in the burner area and can result in an explosion which can cause property damage or severe personal injury.*

1. Set thermostat to desired temperature setting.

### Shut-Down: All Modes

Press mode selector button (F). This will interrupt all AC and DC power and stop operation of the refrigerator.

## Norcold Limited Warranty Time Allowance Chart

### Rialta

To gain access to the operating controls of the refrigerator, remove the drawer directly above the refrigerator. The interrupter can be replaced without removing the refrigerator.

### EuroVan

To gain access to the operating controls of the refrigerator, remove the control panel assembly located directly above the refrigerator.

### Heater Wires

To gain access to the AC and DC heater wires, remove the system cover located on the front left side of the refrigerator.

### Time Allowance

Norcold will pay the time allowance multiplied by the service facility prevailing shop labor rate.

*Note: The time allowances which follow include diagnostic times, defective part replacement, refrigerator removal and reinstallation (when applicable), and gas leak test times.*

A gas leak test is required when gas connections, either the main supply line to the refrigerator or the refrigerator gas components, have been disconnected.

*Note: In the event of a cooling unit failure, the complete refrigerator will be replaced. The time allotted to remove and replace the defective refrigerator will be 1 hr..*

Replacement Part	EuroVan Time Allowance (Hours)	Rialta Time Allowance (Hours)
Burner	1.5	1.5
Burner Tube	1.4	1.4
Electrode Assembly	1.4	1.4
Heater - AC	1.3	1.3
Heater - DC	1.3	1.3
Flame Indicator Lamp	.3	.3
Interrupter	1.3	.5
Mode Selector Switch	1.3	1.3
Orifice	1.3	1.3
Relighter	.4	.4
Safety Valve	1.5	1.5
Thermocouple	1.5	1.5
Thermostat	1.6	1.6
Thermostat By-Pass Screw	.3	.3



# Wiring Pictorial & Diagram

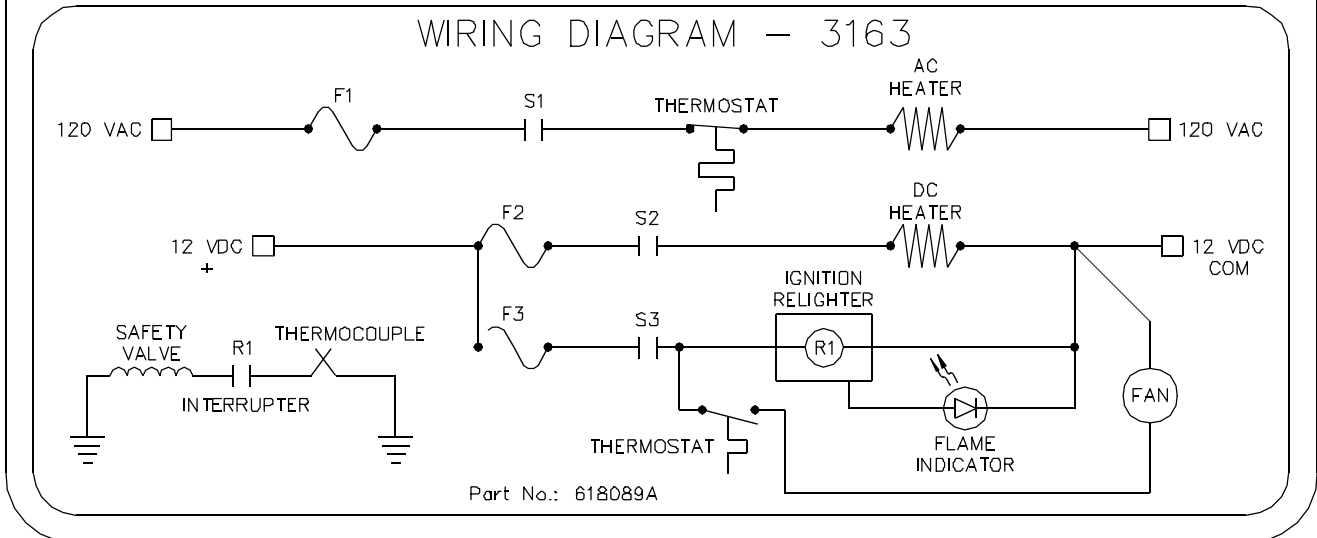
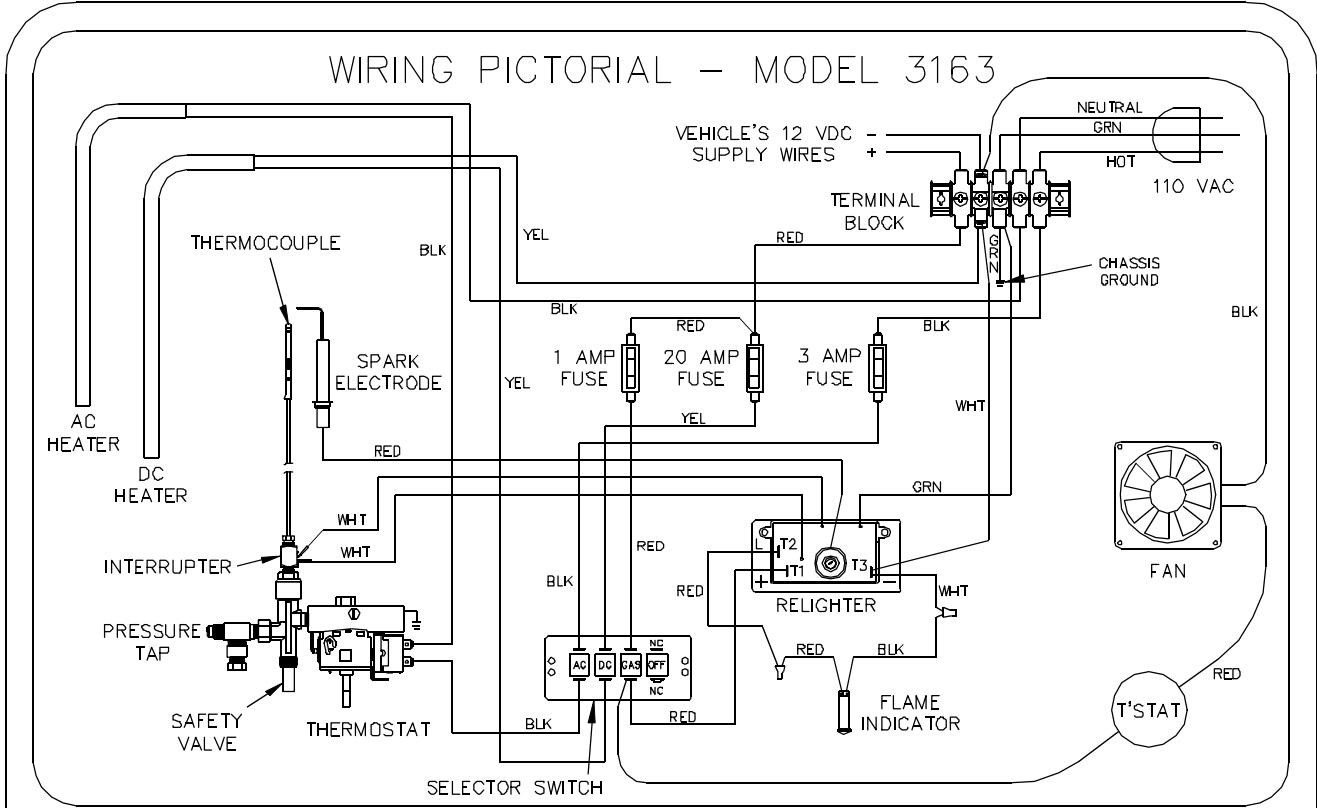

## Important Safety Information - AC Circuit

Read this information before attempting to perform service on this refrigerator. Understand the service procedures before performing the service.



*Always apply the safety precautions on page 1 and the precautions listed below. Failure to follow these safety precautions can result in substantial property damage, severe personal injury, or death.*

- Use caution when performing the AC diagnostic procedures. Disconnect the AC electrical power source to the refrigerator before replacing any AC electrical component.
- Do not remove or cut the round grounding prong from the refrigerator's AC power cord. Do not use a two-prong adapter.
- Replace blown fuses with a fuse specified by Norcold. Refer to "Specifications" section of this manual, or the fuse size printed adjacent to the fuse on the refrigerator.
- Keep liquids away from AC electrical connections. Liquids are electrically conductive and could cause fires.

## WIRING PICTORIAL – AC CIRCUIT MODEL 3163

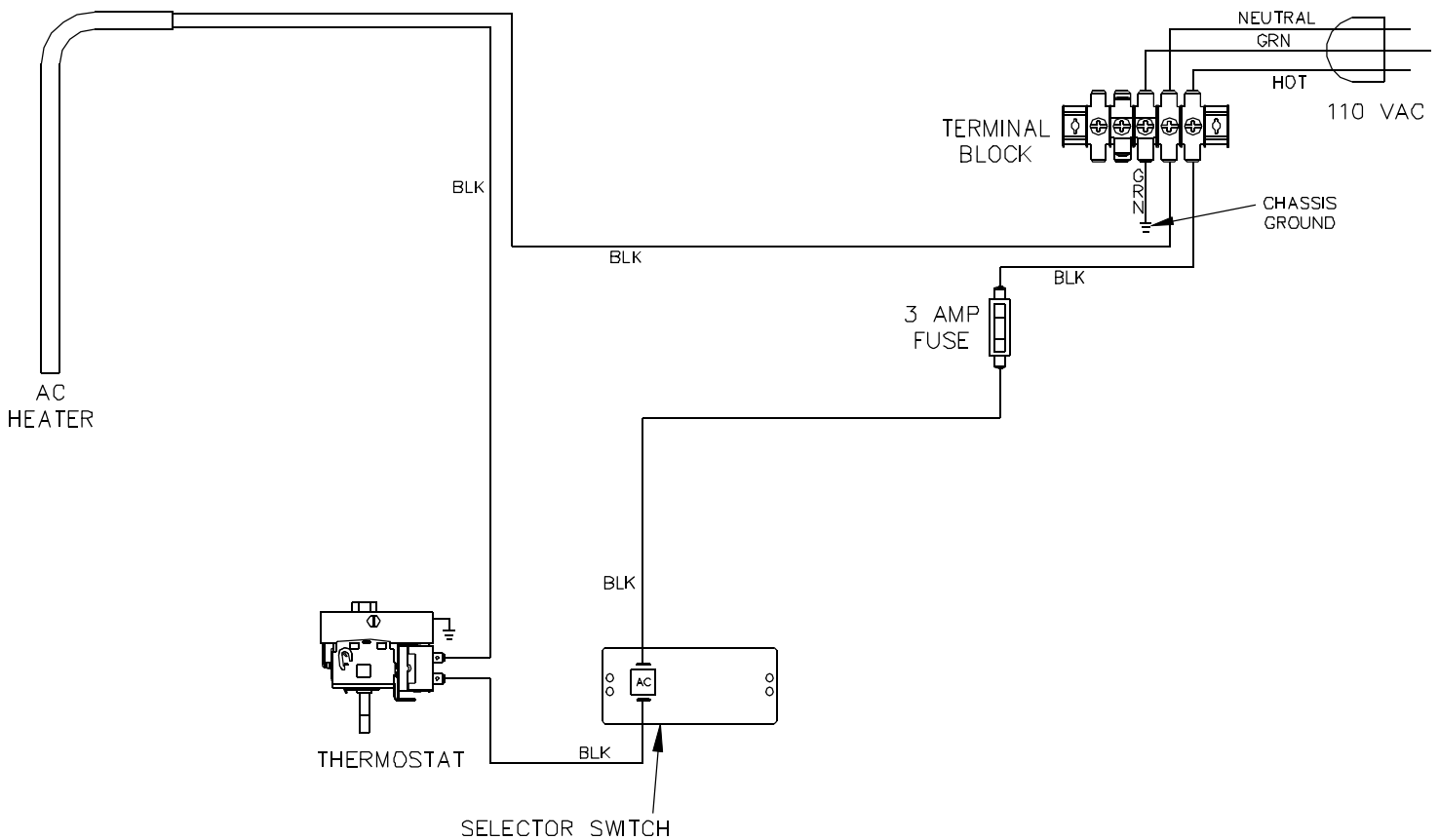

## Refrigerator Will Not Operate on AC

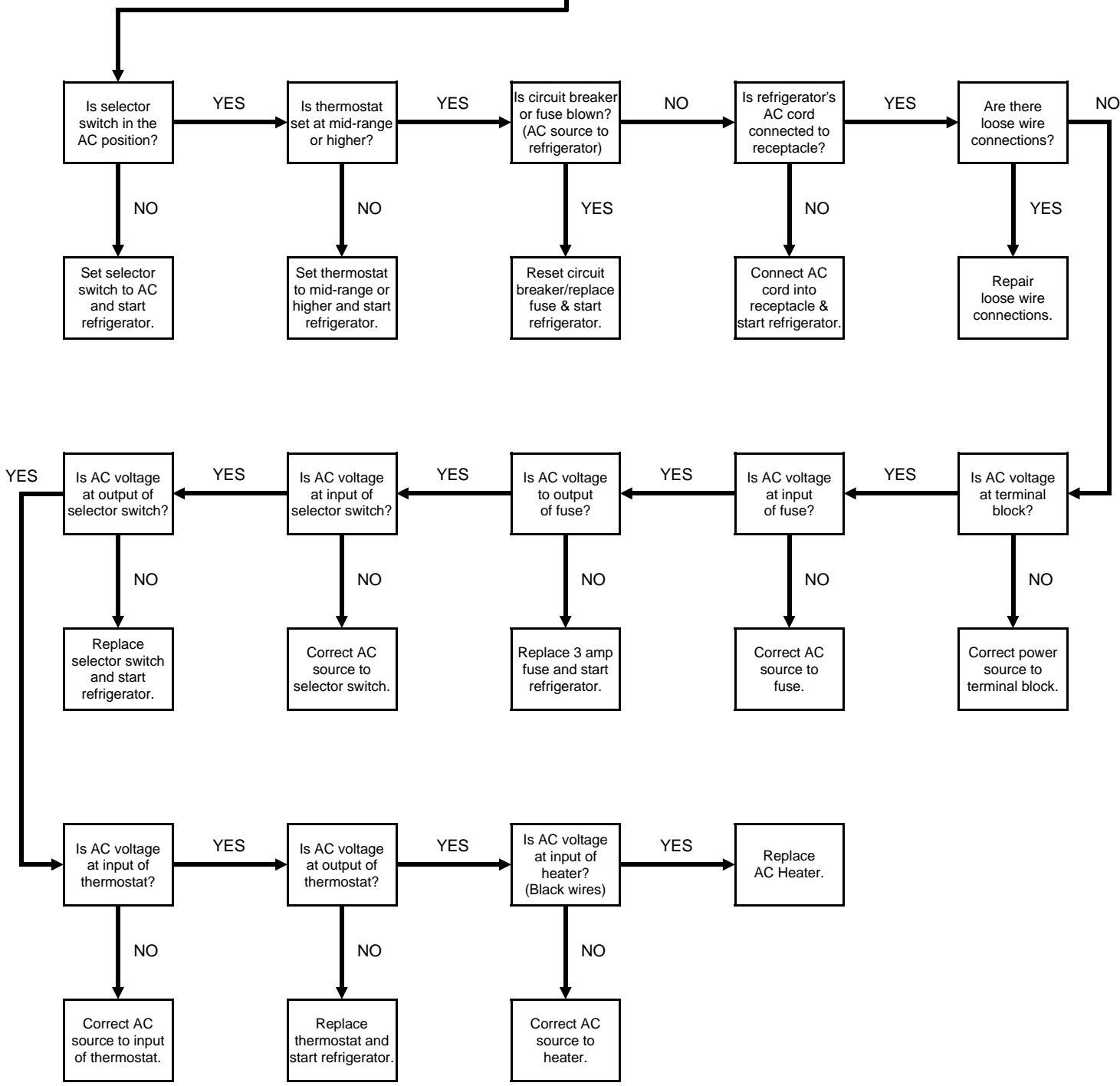

Specifications		
AC Voltage: 108 - 132 VAC	Current Draw: 1.3 - 1.4 amps	Heater Resistance: 81.7 - 90.3 ohms

## Important Safety Information - DC Circuit

Read this information before attempting to perform service on this refrigerator. Understand the service procedures before performing the service.



*Always apply the safety precautions on page 1 and the precautions listed below. Failure to follow these safety precautions can result in substantial property damage, severe personal injury, or death.*

- Use caution when performing the DC diagnostic procedures. Disconnect the DC electrical power source to the refrigerator before replacing any DC electrical component.
- Replace blown fuses with a fuse specified by Norcold. Refer to "Specifications" section of this manual, or the fuse size printed adjacent to the fuse on the refrigerator.
- Connect the positive battery lead to the refrigerator first to prevent short circuits.
- Use caution when connecting or disconnecting the DC supply to the refrigerator. DC supply is close to the propane gas supply to the refrigerator. Arcing can occur and ignite a leak in the propane gas supply piping.

## WIRING PICTORIAL – DC CIRCUIT MODEL 3163

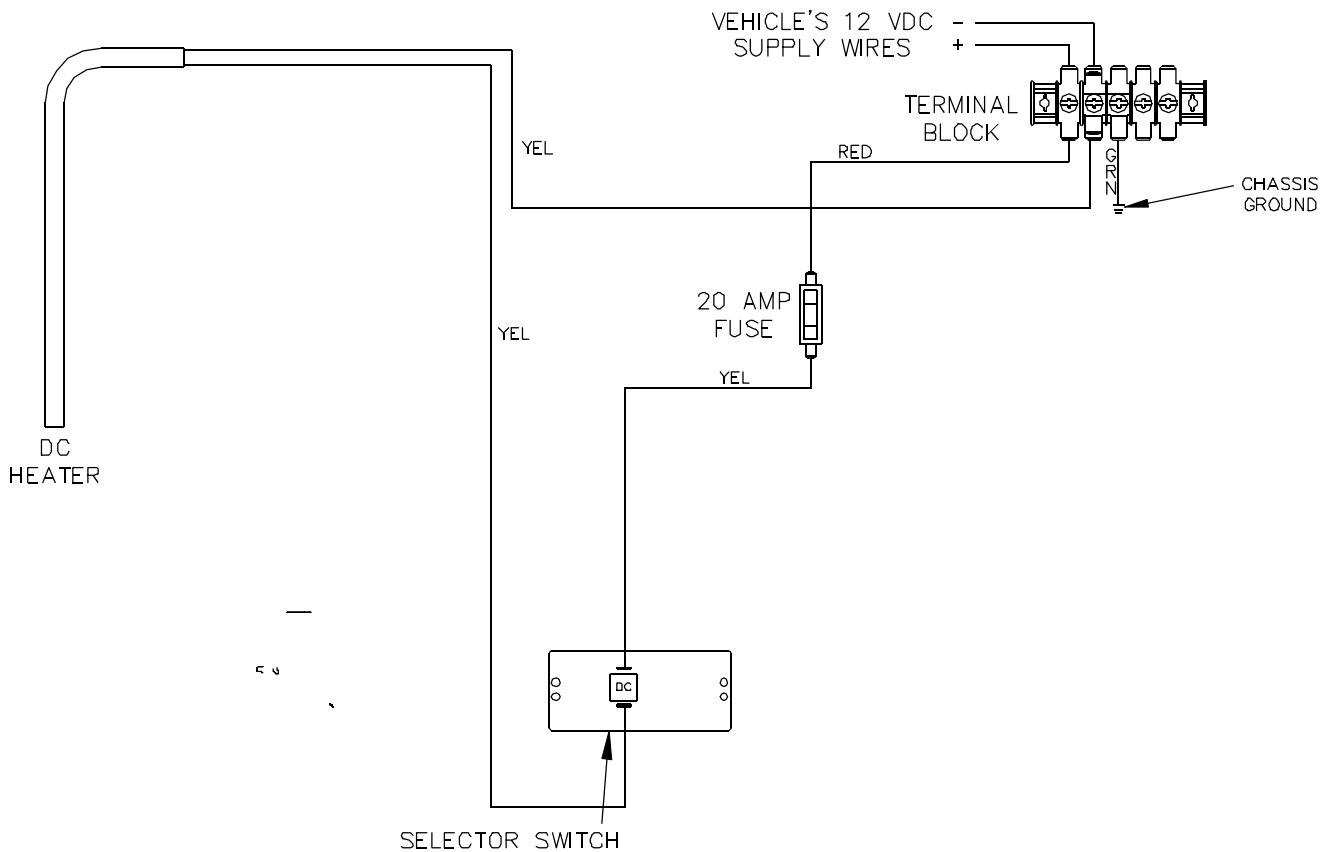

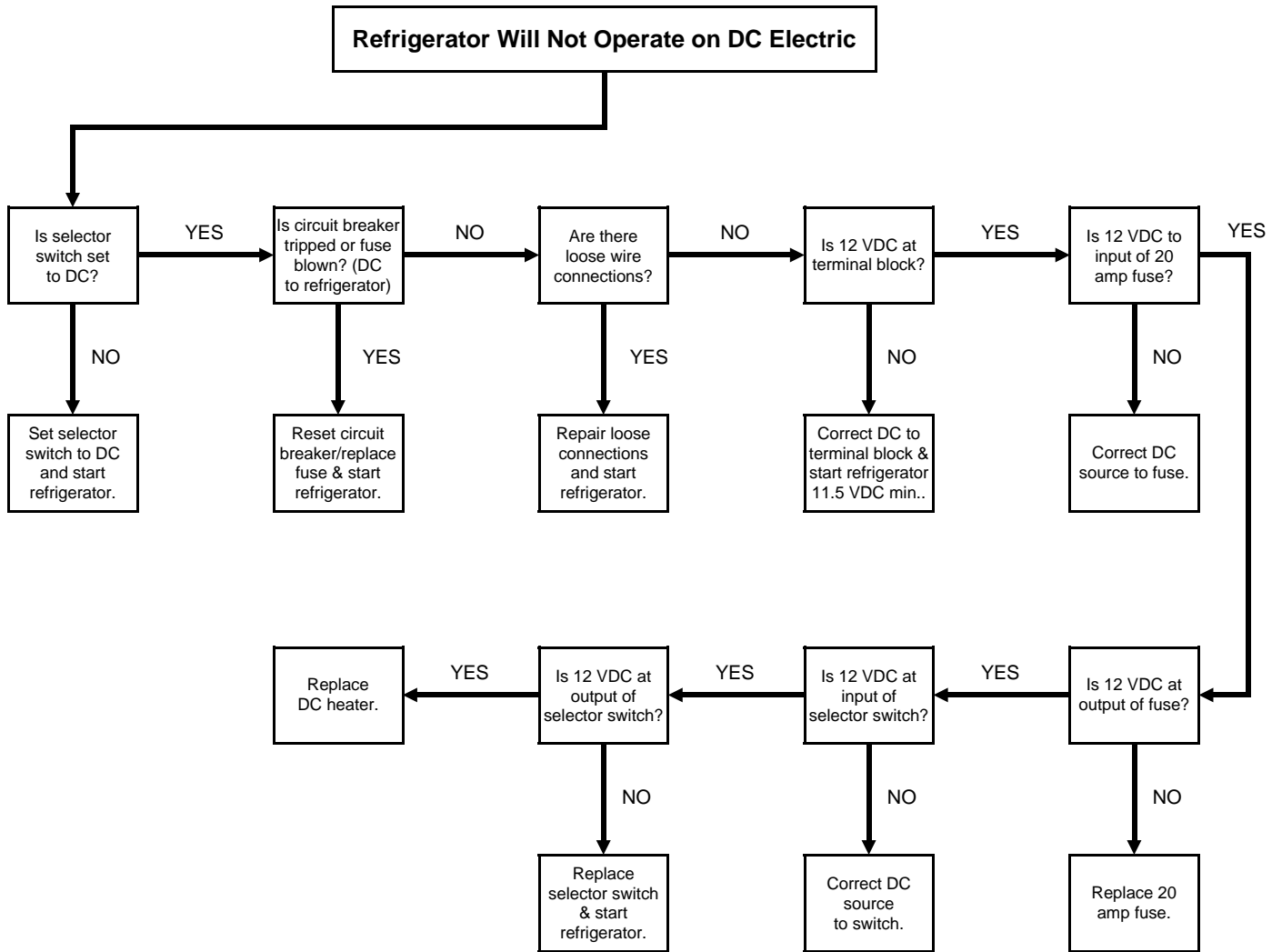

<b>Specifications</b>		
DC Voltage: 11.5 - 15.4 VDC	Current Draw: 11.7 - 13.6 amps	Heater Resistance: .95 - 1.05 ohms

## Important Safety Information - Gas Circuit

Read this information before attempting to perform service on this refrigerator. Understand the service procedures before performing the service.



*Always apply the safety precautions on page 1 and the precautions listed below. Failure to follow these safety precautions can result in substantial property damage, severe personal injury, or death.*

- Propane gas can cause an explosion. Use caution when working with or near a propane gas system. Do not smoke, create sparks, or use an open flame to check gas supply lines or gas connections.
- To prevent gas leaks and damage to the gas supply lines and fittings, use two wrenches when connecting or disconnecting gas fittings (See Figure 1 on page 1).
- Use caution when performing the gas diagnostic procedures. Disconnect both the AC and DC electrical sources to the refrigerator before replacing any gas component.
- Connect the positive battery lead to the refrigerator first to prevent short circuits.
- Replace blown fuses with a fuse specified by Norcold. Refer to "Specifications" section of this manual, or the fuse size printed adjacent to fuse on the refrigerator.
- Use caution when connecting or disconnecting the DC supply to the refrigerator. DC supply is close to the propane gas supply to the refrigerator. Arcing can occur and could ignite a leak in the propane gas supply piping.
- Keep liquids away from electrical connections. Liquids are electrically conductive and could cause a fire.

## WIRING PICTORIAL – GAS CIRCUIT MODEL 3163

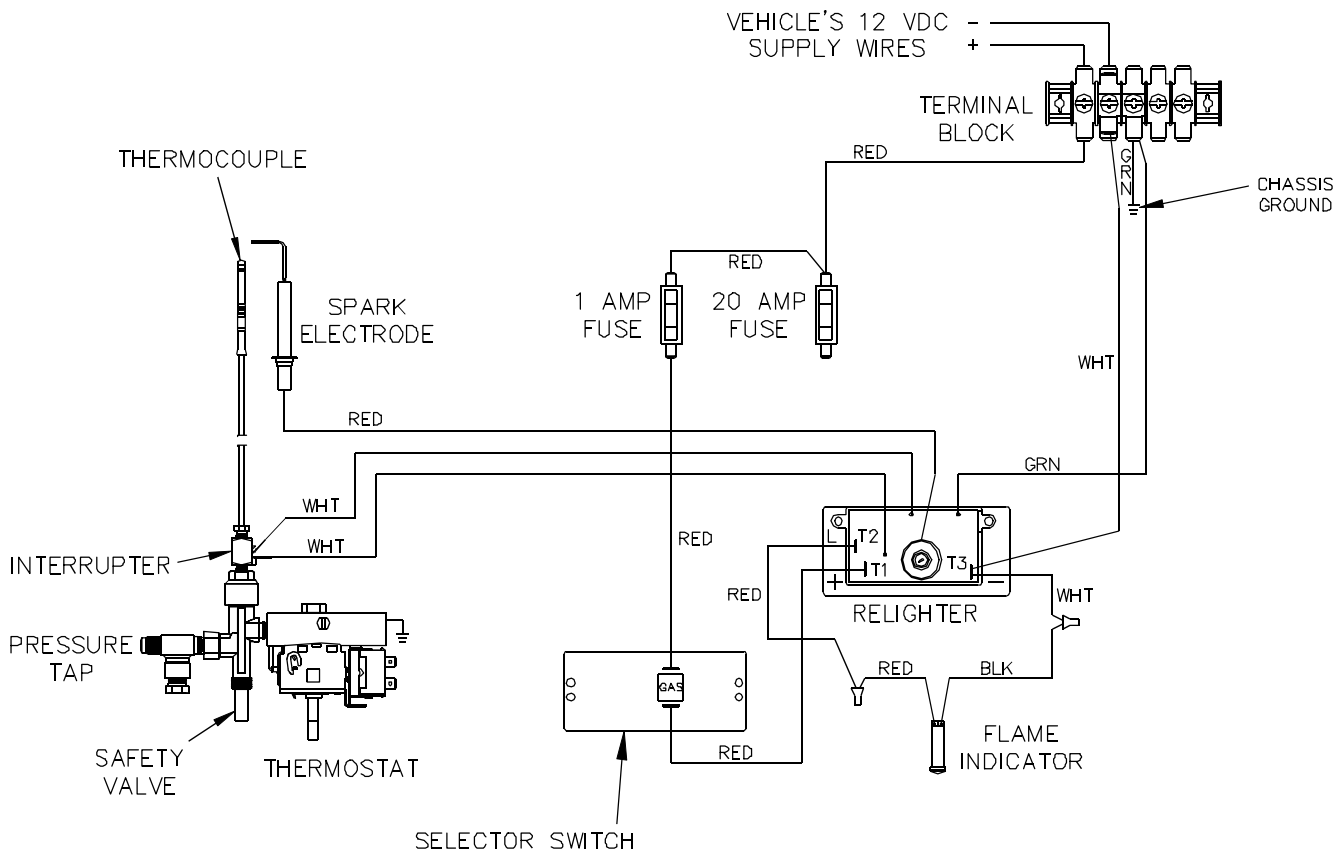

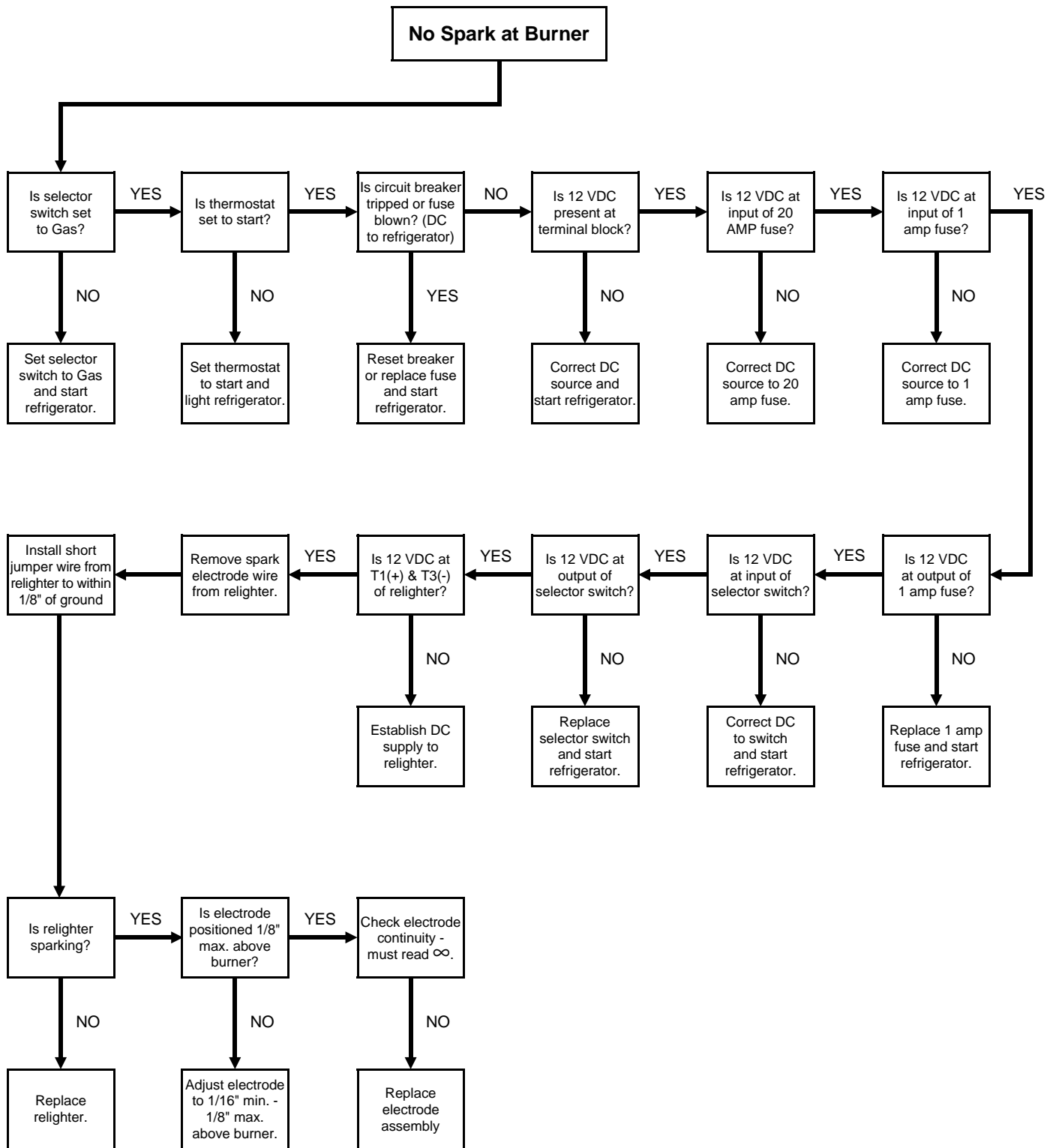

<b>Specifications</b>	
Gas Pressure: 10.5" W.C. - 11" W.C.	DC Voltage: 10.5 - 15.4 VDC

**Note:** If the negative DC supply connection is lost, the flame indicator light will remain on all the time, even without the flame present.

## WIRING PICTORIAL — GAS CIRCUIT MODEL 3163

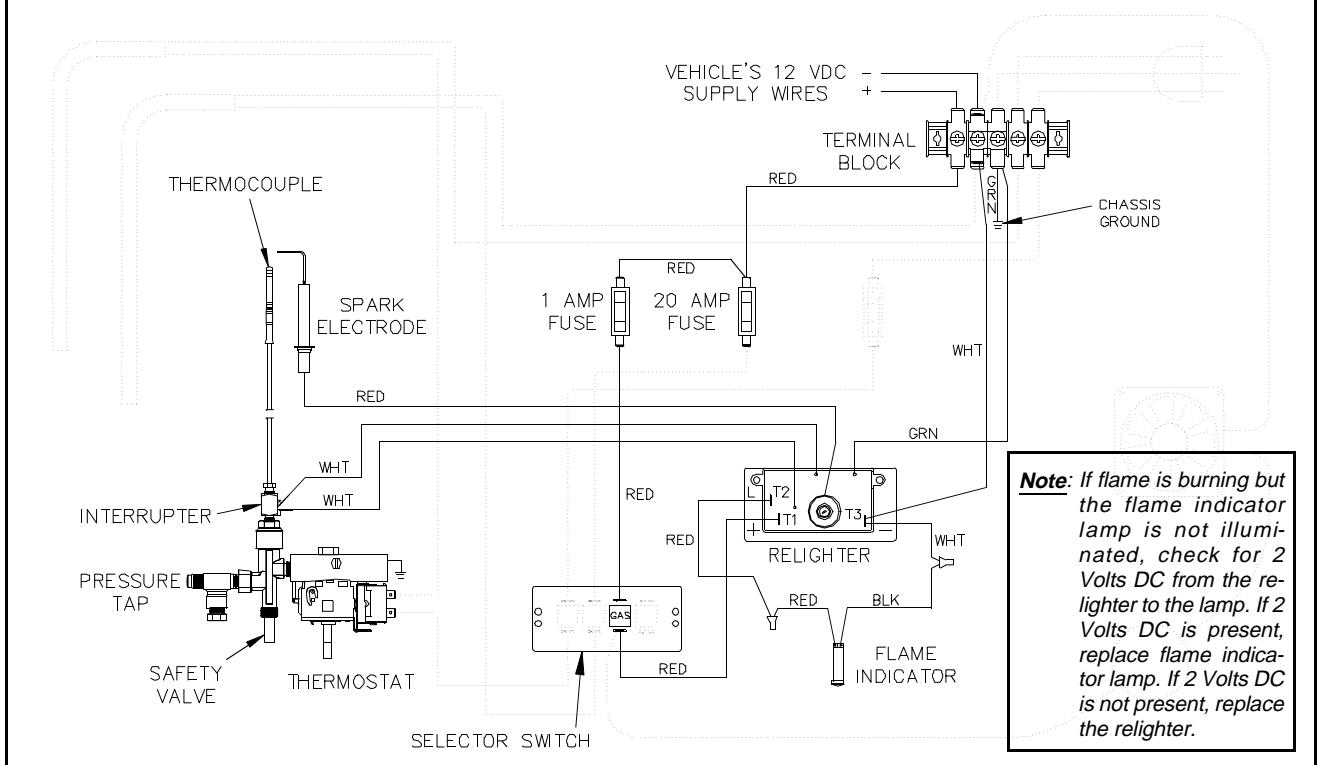

Figure 9

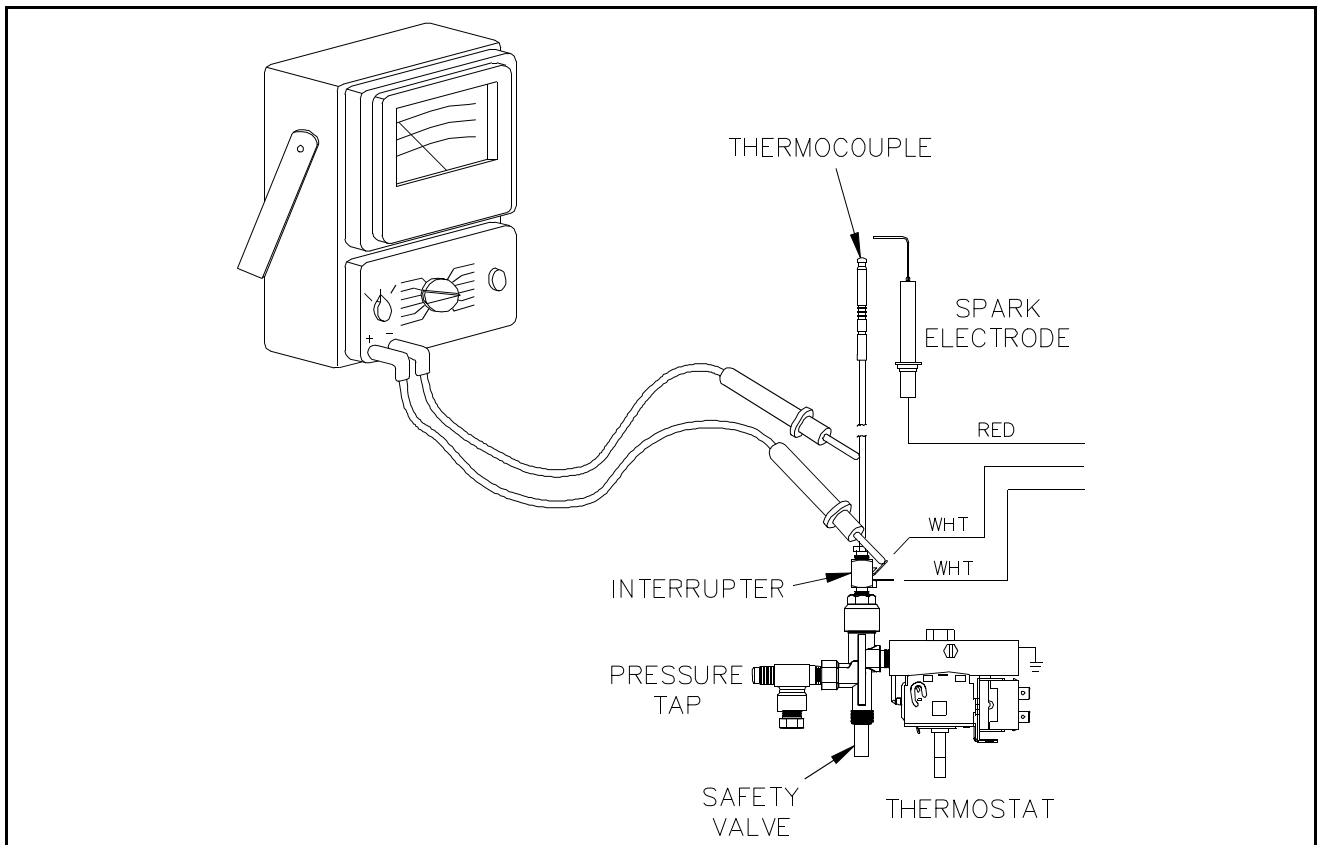
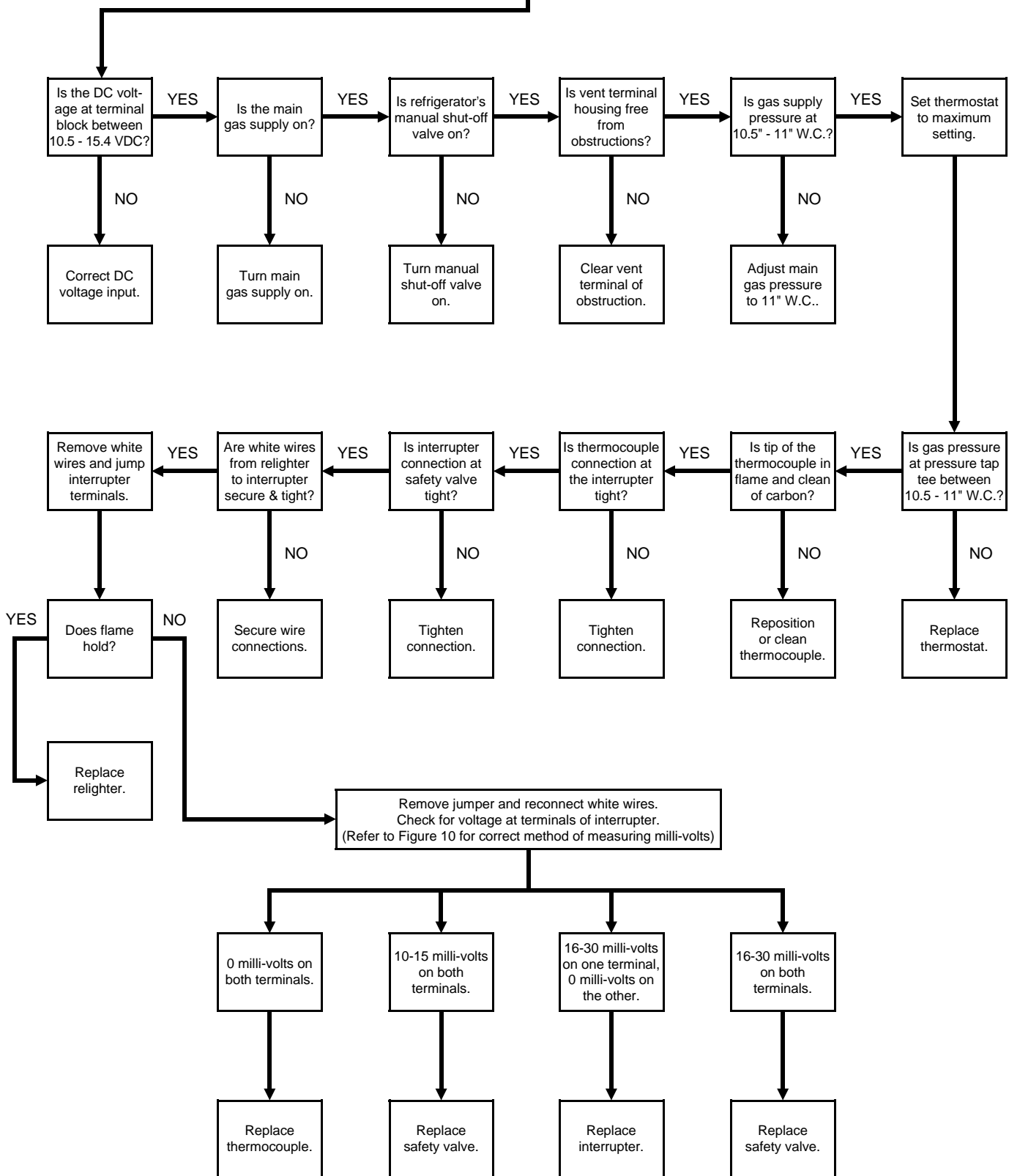

Figure 10



## Burner Ignites But Flame Will Not Hold



**Note:** If the negative DC supply connection is lost, the flame indicator light will remain on all the time, even without the flame present.

## Important Safety Information - DC Fan Circuit

Read this information before attempting to perform service on this refrigerator. Understand the service procedures before performing the service.



*Always apply the safety precautions on page 1 and the precautions listed below. Failure to follow these safety precautions can result in substantial property damage, severe personal injury, or death.*

- Propane gas can cause an explosion. Use caution when working with or near a propane gas system. Do not smoke, create sparks, or use an open flame to check gas supply lines or gas connections.
- To prevent gas leaks and damage to the gas supply lines and fittings, use two wrenches when connecting or disconnecting gas fittings (See Figure 1 on page 1).
- Use caution when performing the gas diagnostic procedures. Disconnect both the AC and DC electrical sources to the refrigerator before replacing any gas component.
- Connect the positive battery lead to the refrigerator first to prevent short circuits.
- Replace blown fuses with a fuse specified by Norcold. Refer to "Specifications" section of this manual, or the fuse size printed adjacent to fuse on the refrigerator.
- Use caution when connecting or disconnecting the DC supply to the refrigerator. DC supply is close to the propane gas supply to the refrigerator. Arcing can occur and could ignite a leak in the propane gas supply piping.
- Keep liquids away from electrical connections. Liquids are electrically conductive and could cause a fire.

## WIRING PICTORIAL – DC FAN CIRCUIT MODEL 3163

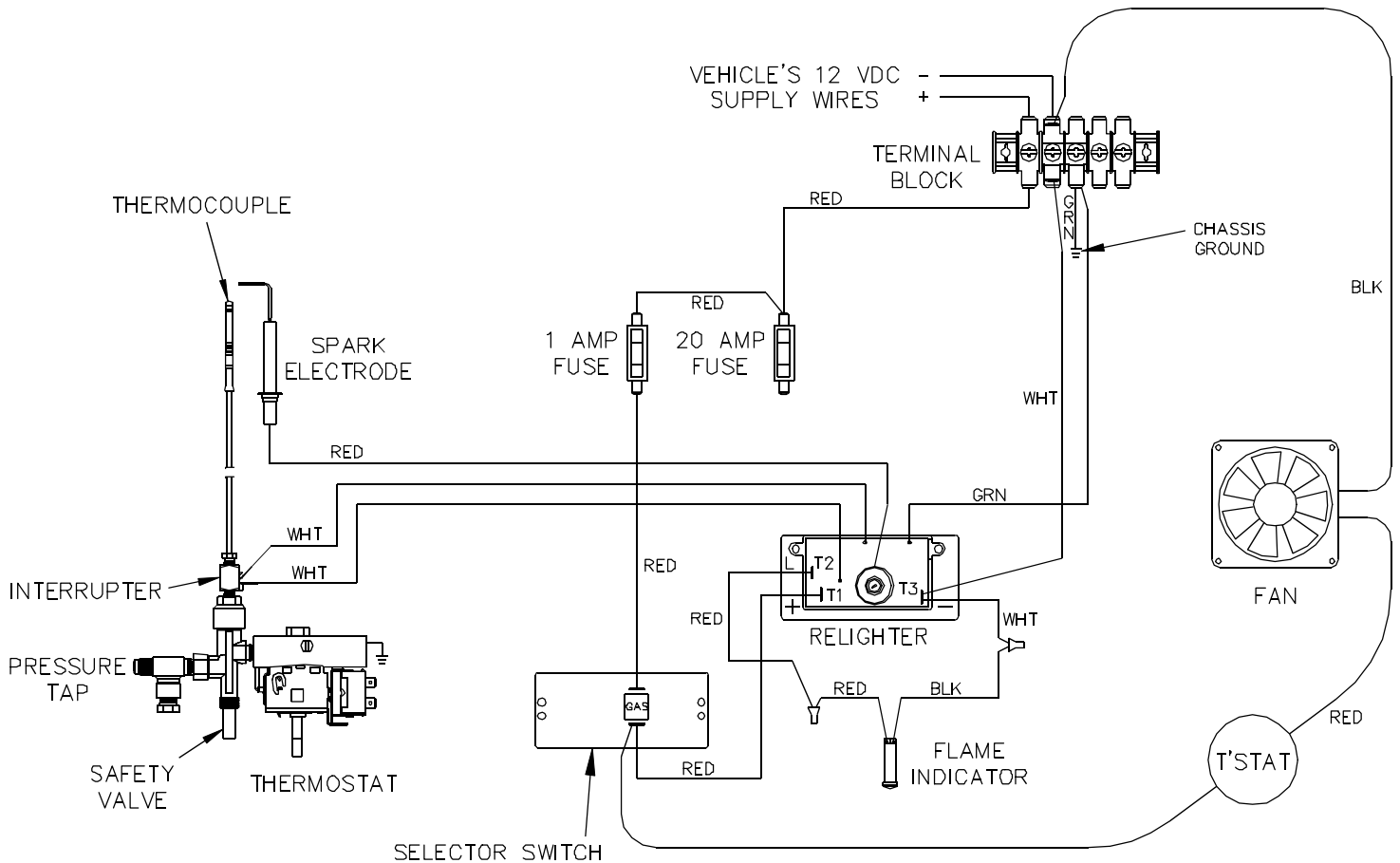

## Trouble Shooting - Ventilation Fan

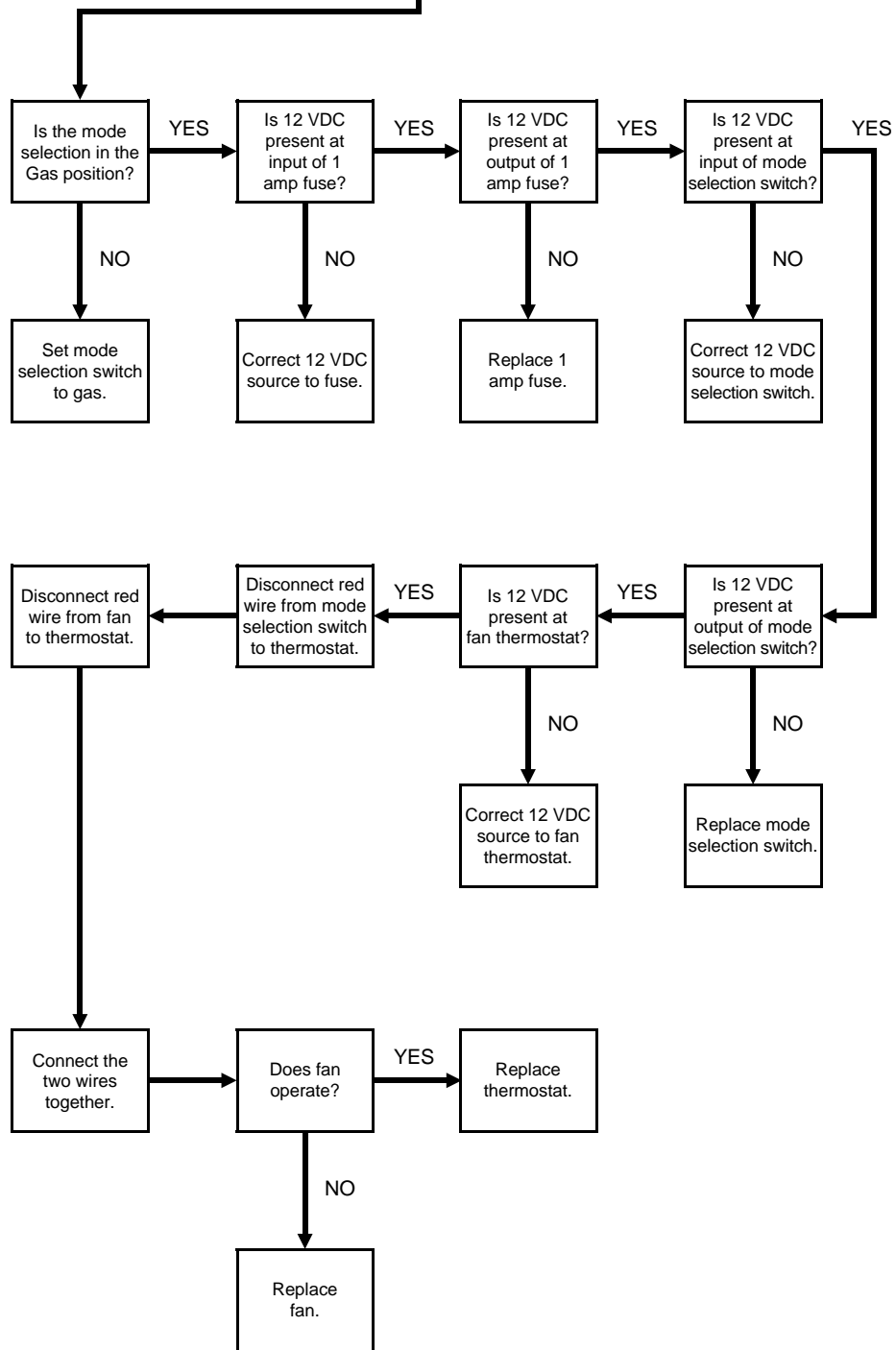

### Specifications

DC Voltage: 12 VDC

Current Draw: .240 milliamps

## Diagnosing Cooling Problems

Read this information before attempting to perform service on this refrigerator. Understand the service procedures before performing the service.



*Always apply the safety precautions on page 1 and the precautions listed below. Failure to follow these safety precautions can result in substantial property damage, severe personal injury, or death.*

- Never bend, drop, drill, weld, or hammer the cooling unit. Doing so can cause the cooling unit to rupture, releasing chemicals under high pressure. Contact with these chemicals may cause severe burns to the eyes or skin.
- Never attempt to repair or recharge the cooling unit. A defective cooling unit must be replaced.

### Diagnostic Procedures

1. Make sure the cooling problem occurs while operating the refrigerator in each mode of operation. If not, the cooling problem is not the cooling unit. Refer to Trouble Shooting sections to determine cause for insufficient cooling on identified mode of operation.
2. Make sure the interior venting is not obstructed and is providing air circulation across the cooling unit's absorber coils and condenser fins.
3. Make sure the 12 VDC ventilation fan is functional. The fan will operate whenever the vehicle's interior temperature reaches 85° or higher.

See pictorial and trouble shooting guide on pages 17 & 18.

4. An off-level situation, if the infraction is marginal, will allow the refrigerator to continue to operate at a reduced level of cooling until the refrigerator is leveled. Greater off-level situations will stop the refrigerant circulation and cease cooling. Normal vehicle leveling to provide comfort for the occupants is within the refrigerator's operating limits. The refrigerator's operating limits are 3 degrees off-level front-to-back and 6 degrees off-level side-to-side. Operating the refrigerator outside of these operating limits for an extended time will cause irreparable damage to the cooling unit.
5. Check the input voltages and gas pressure to insure correct heat input and voltage limits. The specifications are as follows:
  - a. 120 VAC - 108 VAC min. to 132 VAC max.
  - b. 12 VDC - 11.5 VDC min. to 15.4 VDC max.
  - c. Gas - 10.5" W.C. min. to 11" W.C.Correct input voltages and propane gas supply are critical for the cooling unit to function properly.
6. Check the area of the cooling unit for refrigerant leaks. The smell of ammonia is a positive sign of a refrigerant leak. When an ammonia smell is detected, the cooling unit must be replaced. Another sign of a refrigerant leak is the appearance of a yellow powder in the vicinity of the cooling unit. When this powder is observed, the cooling unit must be replaced.
7. Check the absorber coils; the bottom coil will be warm and the top coil will be cooler. If the coils are cold and the cooling units flue enclosure is too hot to touch, there is a blockage in the cooling unit and the cooling unit must be replaced.

## Refrigerator Removal Procedures

### **⚠ WARNING**

Improper removal and installation of the refrigerator can cause injury or property damage. Before attempting the procedures below, review the "Important Safety Information" on page 1 and the procedures below.

### EuroVan Camper

1. Turn off the gas supply at the main tank.
2. Turn the refrigerator's mode selector to "OFF".
3. Remove the vehicle's middle bench seat.
4. Remove the refrigerator's system cover located on the left front of the refrigerator by removing 5 retaining screws.
5. Remove 5 retaining screws securing refrigerator to enclosure.
6. Remove the monitor panel located directly above the refrigerator by removing 6 retaining screws.  
**CAUTION: It is not necessary to disconnect wiring from the monitor panel. Pull panel forward and away from the monitor panel's mounting bracket. Lay monitor panel on galley top. Take care not to scratch the galley and its surrounding surfaces, or the face of the control panel.**
7. Remove the monitor panel's mounting (frame) bracket by removing four retaining screws. The retaining screws are located on both the left and right sides of the bracket.

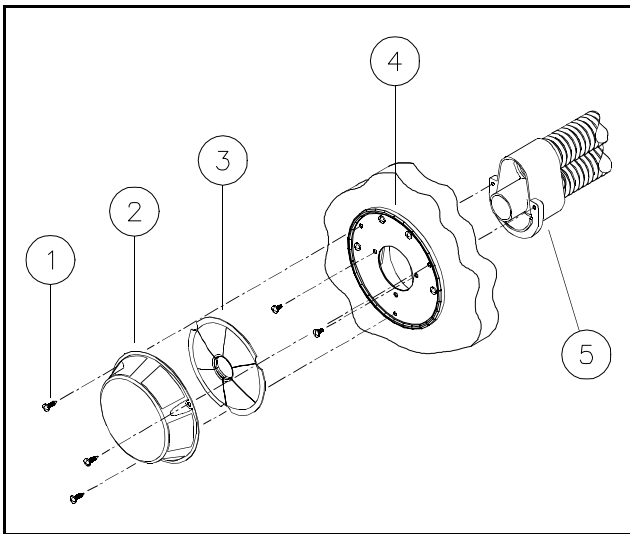

Figure 11 - Vent Terminal Housing

8. Turn the manual shut-off valve located on top of the refrigerator to "OFF". See Figure 12.

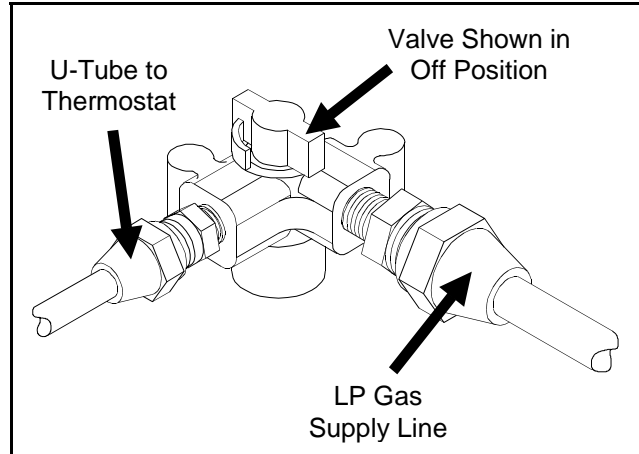

Figure 12 - Manual Shut-Off Valve

9. Remove both the positive and negative leads from the vehicle's battery.
10. Disconnect the vehicle's 12 volt DC supply wires from the refrigerator's terminal block.
11. Disconnect the LP gas supply line from the refrigerator's manual shut-off valve. See Figure 12.  
**CAUTION: To prevent gas leaks or damage to the gas supply lines and fittings, use two wrenches when connecting or disconnecting gas fittings.**
12. Remove the three (3) screws securing the vent cover to the vehicle's exterior surface. See Figure 11.
13. Remove the two (2) screws securing the inner disk to the vent terminal housing. See Figure 11.
14. Carefully push the vent terminal housing inward until free from the vehicle's wall.
15. Carefully pull the refrigerator forward to gain access to the refrigerator's AC power cord. Disconnect the refrigerator's AC power cord from the wall receptacle.
16. Remove the refrigerator from its enclosure.
17. To re-install the refrigerator, reverse the removal procedure.
18. After connecting the vehicle's gas supply line to the refrigerator's manual shut-off valve, turn the valve on. Use a manometer and verify that the input gas pressure is at 11" W.C..
19. Turn off the gas supply at the manual shut-off valve. Observe the manometer and verify that the gas pressure is maintained. If not, locate the source of the leak, correct it, and re-test the unit.
20. Apply leak test solution to all gas fittings and verify that there are no leaks. **Do not test for gas leaks with an open flame.**

## Rialta

1. Turn off the gas supply at the main tank.
2. Turn the refrigerator's mode selector to "OFF".
3. Remove the refrigerator's system cover located on the left front of the refrigerator by removing 5 retaining screws.
4. Remove 5 retaining screws securing the refrigerator to the enclosure.
5. Remove the drawer directly above the refrigerator.
6. Turn the manual shut-off valve located on top of the refrigerator to "OFF". See Figure 12.
7. Disconnect the vehicle's 12 volt DC supply wires from the refrigerator's terminal block.
8. Disconnect the LP gas supply line from the refrigerator's manual shut-off valve. See Figure 12.  
**CAUTION: To prevent gas leaks and damage to the gas supply lines and fittings, use two wrenches when connecting or disconnecting gas fittings.**
9. Disconnect the refrigerator's AC power cord from the wall receptacle.
10. Open the cabinet door to the left of the refrigerator. Remove the access panel at the rear of the cabinet. This will allow access to the refrigerator's vent-air intake and exhaust piping.

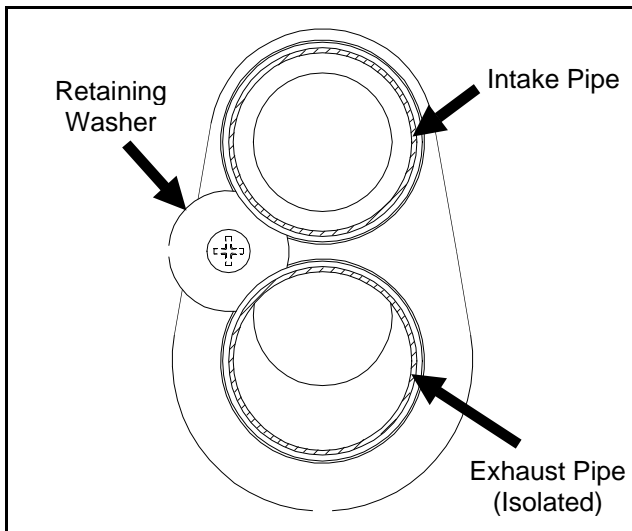
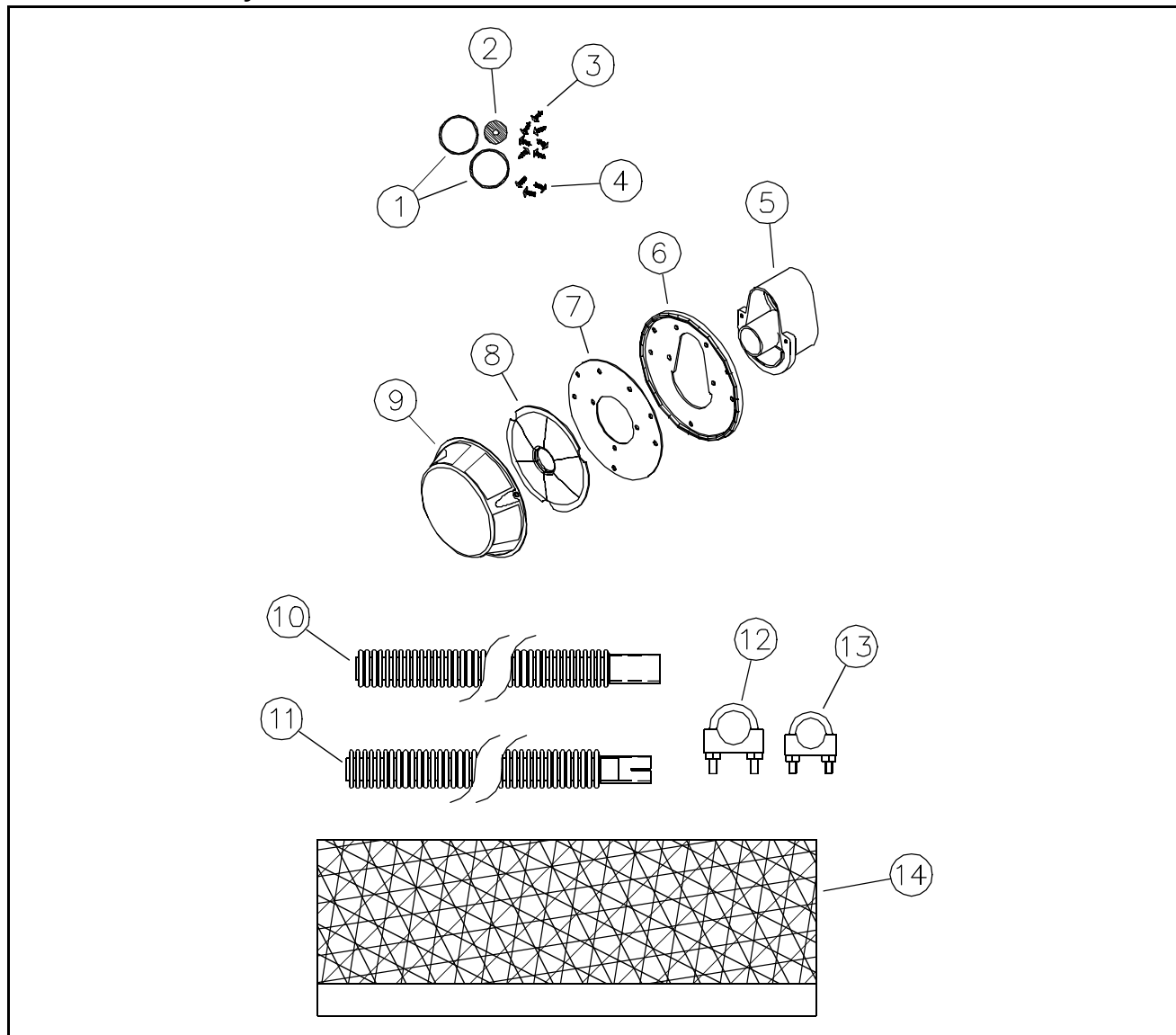

Figure 13 - Vent Terminal Housing

11. Remove the phillips head screw and retaining washer which secure the vent-air exhaust and intake flexible vent piping to the vent terminal housing. See Figure 13.
12. Remove both the intake and exhaust vent piping from the vent terminal housing. ***Care must be taken not to damage the "O" ring seals when removing the piping.***
13. Remove right dinette assembly cover panel to access the refrigerator retaining bracket. Reference "Right Dinette Assembly Cover Panel Removal" in the Interior Section.
14. Loosen and remove the refrigerator's retaining screws at rear base of the refrigerator.
15. Position the flexible vent-air intake and exhaust piping to remove the refrigerator from its enclosure.
16. To re-install the refrigerator, reverse the removal procedure.
17. After connecting the vehicle's gas supply line to the refrigerator's manual shut-off valve, turn the valve on. Use a manometer and verify that the input gas pressure is at 11" W.C..
18. Turn off the gas supply at the manual shut-off valve. Observe the manometer and verify that the gas pressure is maintained. If not, locate the source of the leak, correct it, and re-test the unit.
19. Apply leak test solution to all gas fittings and verify that there are no leaks. **Do not test for gas leaks with an open flame.**

## Vent Kit Assembly - 3163



No.	Part No.	Description
1	617980	O-Ring
2	617773	Washer
3	61761122	Screw #8 - 15 x 1/2" S.S.
4	61633330	Screw #8 - 32 x 5/16"
5	617923	Vent Terminal Housing
6	617924	Vent Terminal Gasket
7	617922	Back Plate
8	617921	Exhaust Disk
9	617920	Vent Cover
10	617985	Air Inlet Tube (EuroVan)
	618007	Air Inlet Tube (Rialta)
11	618428	Air Exhaust Tube (EuroVan)
	618429	Air Exhaust Tube (Rialta)
12	618008	Clamp 1.125
13	618030	Clamp 1.000
14	618022	Insulation 14"
	618023	Insulation 19"

# Final Assembly - 3163

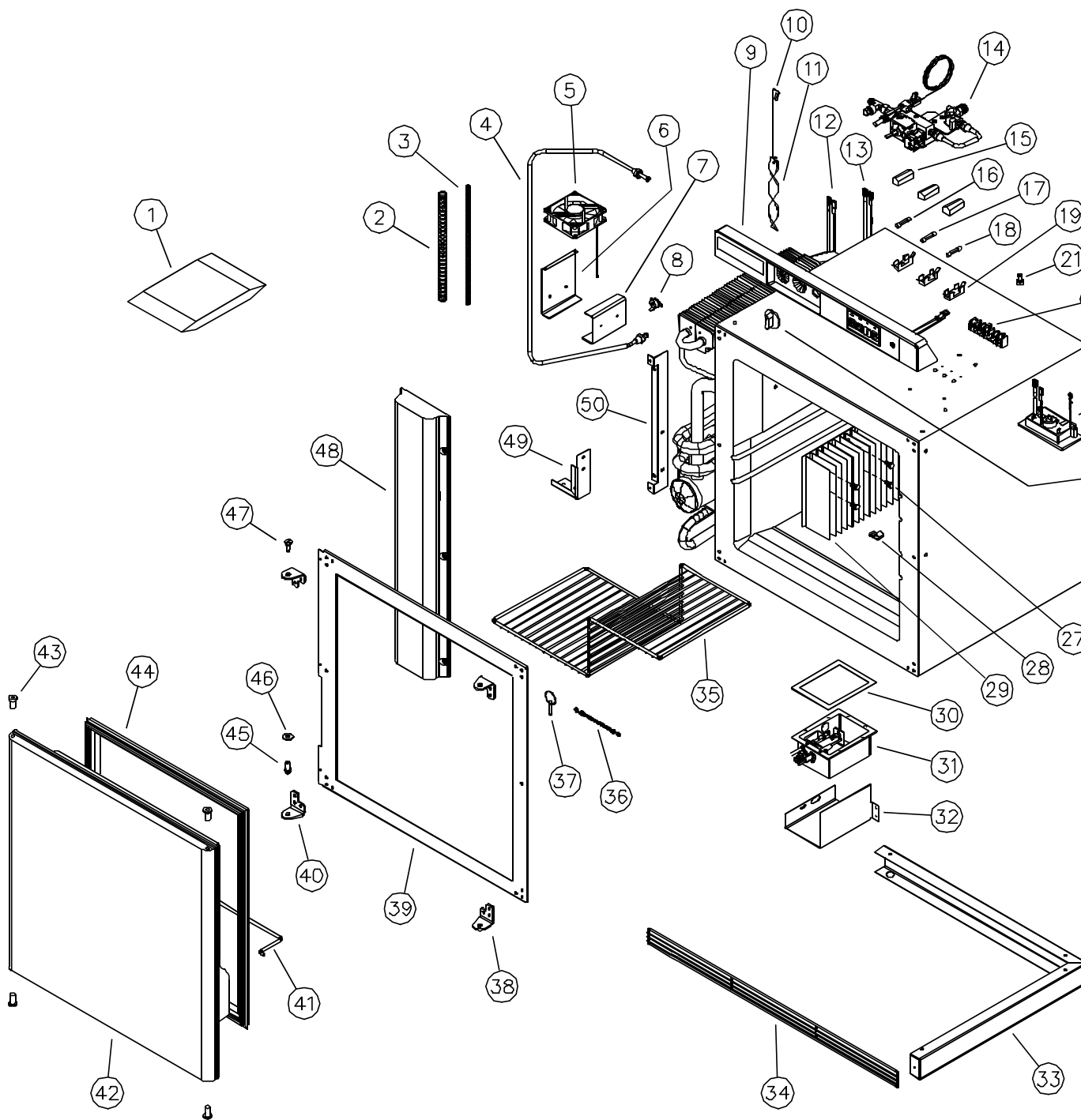



## Final Assembly - 3163

<u>No.</u>	<u>Part No.</u>	<u>Description</u>
1	617916	Information Packet
2	618014	Wire Conduit
3	618013	Wire Conduit
4	617989	Burner Tube
5	618073	DC Fan
6	618403	Fan Support
7	618404	Fan Support Bracket
8	618093	Thermostat (Fan)
9	618021	Control Cover Assembly
10	617961	Flue Baffle Wire
11	617960	Flue Baffle
12	61562622	DC Heater (Yellow Leads)
13	61562522	AC Heater (Black Leads)
14	617998	Control Assembly
15	61583322	Fuse Cover
16	618079	1 Amp Fuse
17	61440522	20 Amp Fuse
18	61654622	3 Amp Fuse
19	61584222	Fuse Holder
20	617918	AC Power Cord
21	61705422	End Splice
22	617979	Terminal Block
23	617993	Cabinet Assembly (w/Cooling Unit)
24	617964	Relighter
25	617971	Gas Valve/Thermostat Knob
26	617947	Mounting Angle (Right)
27	61749622	Fin Screws
28	61728722	Fin Clip
29	61721122	Fins
30	617977	Burner Box Cover Gasket
31	617937	Burner Box Assembly
32	618067	Burner Box Heat Shield
33	617908	Lower Support Panel
34	618032	Grille
35	618063	Wire Shelf (White)
36	618047	Chain (Travel Latch)
37	618046	Pin (Travel Latch)
38	617911	Hinge
39	617912	Breaker
40	617910	Hinge
41	618064	Wire Door Rail
42	617914	Taupe Door Assembly (w/Gasket & Door Rail)
	618000	Taupe Foamed Door (wo/Gasket & Door Rail)
	617915	Gray Door Assembly (w/Gasket & Door Rail)
	617999	Gray Foamed Door (wo/Gasket & Door Rail)
43	617420	Hinge Bushing
44	617906	Door Gasket
45	61550722	Hinge Pin
46	61645522	Spacer
47	611114600	Hinge Pin
48	617905	System Cover (Gray)
	617904	System Cover (Taupe)
49	617909	Mounting Bracket (Left Front)
50	617946	Mounting Angle (Left)

## Control Cover Assembly - 3163

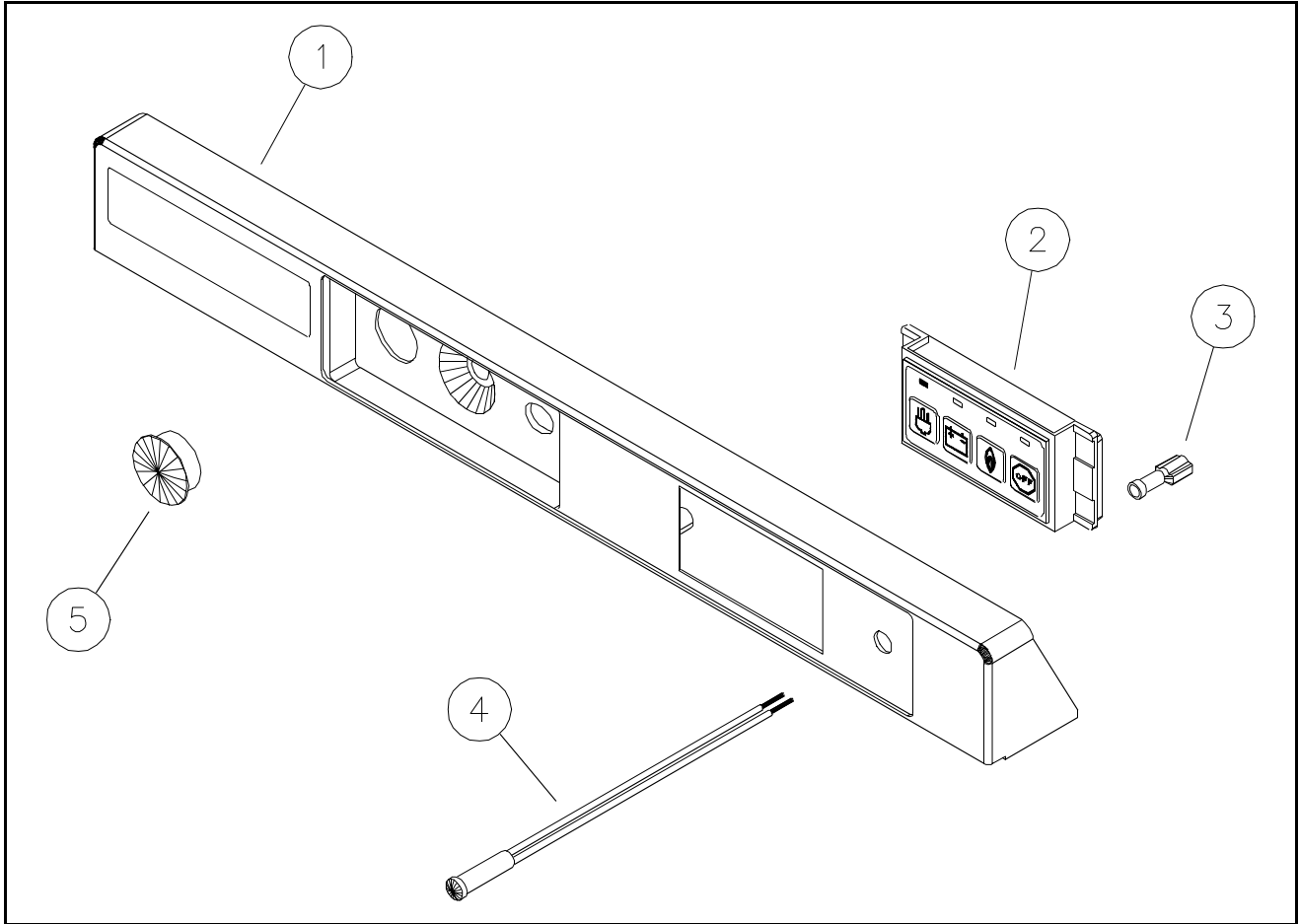

No.	Part No.	Description
1	617913	Control Cover
2	617945	Mode Selection Switch
3	618040	Terminal Connector
4	61609022	Indicator Lamp
5	617981	Hole Plug

## Control Assembly - 3163

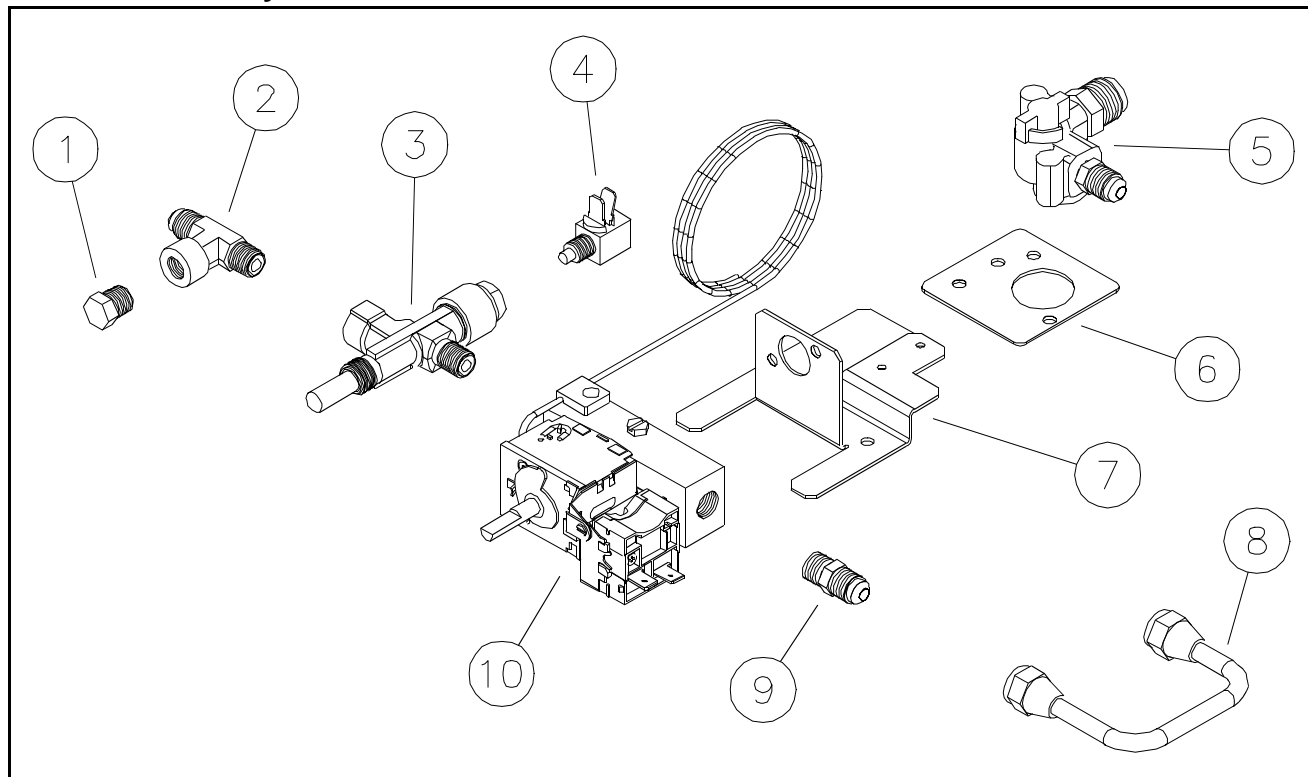

No.	Part No.	Description
1	61445322	Plug
2	61594422	Fitting
3	617965	Safety Valve
4	61750522	Interrupter
5	617976	Manual Shut-Off Valve
6	61749822	Gas Valve Mounting Bracket
7	617952	Thermostat Control Mounting Bracket
8	61694622	U-Tube
9	61546822	Fitting
10	617944	Thermostat Control

## Burner Box Assembly - 3163

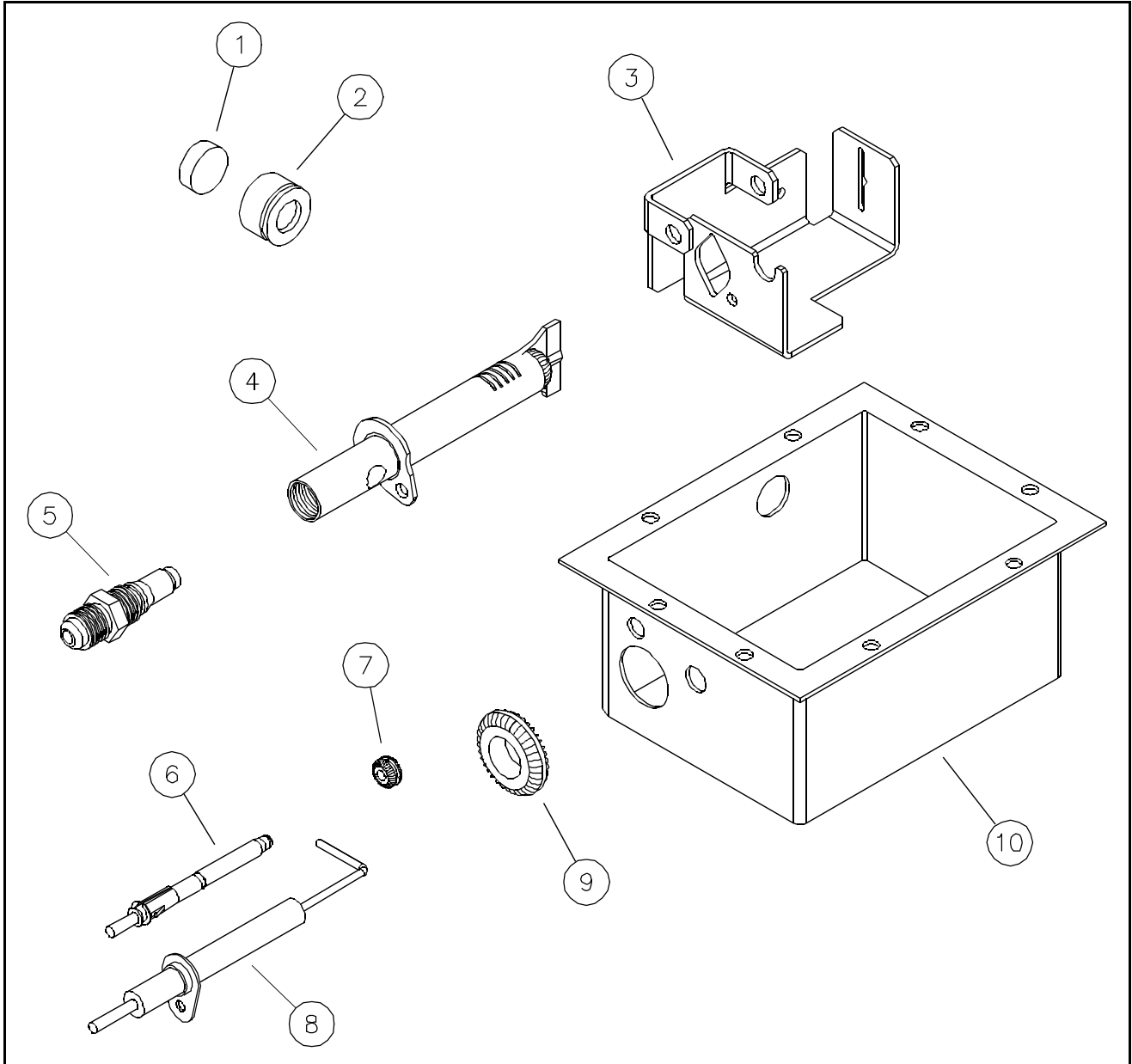

No.	Part No.	Description
1	617995	Sight Glass
2	617933	Sight Glass Grommet
3	617927	Burner Support Bracket
4	617936	Burner Assembly
5	61753137	Orifice Adapter Assembly
6	617983	Thermocouple
7	617997	Thermocouple Grommet
8	617966	Spark Electrode
9	617996	Burner Grommet
10	617925	Burner Box Bottom