

FOR YOUR SAFETY

- If you smell gas:
1. Open windows.
 2. Don't touch electrical switches.
 3. Extinguish any open flame.
 4. Immediately call your gas supplier.

INNOVATORTM
SERVICE MANUAL^{S975}

GAS/ELECTRIC REFRIGERATORS
IM-40, IM-60, IM-70, and IM-90 Series





IMPORTANT

The installation must conform with the following American National Standards:

1. National Fuel and Gas Code: ANSI Z223.1-1974
2. Mobile Homes: A119.1-1975
3. Recreational Vehicles: A119.2-1975
4. The unit must be electrically grounded in accordance with the National Electrical Code: ANSI C1-1975

In Canada, the appliance must be installed in accordance with:

1. CSA Standard Z240.4 — Gas Equipped Recreational Vehicles and Mobile Housing
 2. CSA Standard Z240.6.1 — Electrical Requirements for Mobile Homes
- OR**
3. CSA Standard Z240.6.2 — Electrical Requirements for Recreational Vehicles
 4. Any applicable local codes and regulations



WARNING:

Tampering with cooling unit will void warranty . . . UNLESS by an Instamatic Certified Cooling Unit Technician

**CONTENTS HIGHLY
FLAMMABLE
AND TOXIC!**

See page 47.

Table of Contents

Absorption Cooling Unit

Air Circulation	4
Analysis Tips	8
Diagram	2
Fill Valve	47
Refrigeration Cycle	1
Replacement	22
Things to Do Before Returning	47
Types and Part Numbers	21

Burner

Changing:	
Gas Line	23
Orifice	23
Thermocouple	23
Drawings: Parts List	28, 32
Flue Assembly	13
Pressure Measurement	20
Orifice Sizes	12
Odors	11
Service Hints	11
Start-Up	9
Trouble-Shooting	24

Cleaning	10
----------------	----

Cooling Unit

Before Returning;	
"Things to Do"	47
Changing	22
Identification	21
Trouble-Shooting	45, 46

Doors

Access Doors:	
#1422, #1422R	7
Changing Decorative Panel ..	14
Changing Swing	15, 16
Replacing Freezer Door	17
Travel Lock	15

Electric

Element Identification and Wiring	39-44
Operation Analysis	46
Recommended Wire Gauges ..	6
12 Volt Wiring Instructions ...	6
Thermostat: "Lost Charge" ...	11
Wiring Diagrams	33-47

Flue Assembly

Cleaning	12
Diagrams	13
Obstructions	11

Gas Trouble-Shooting	24
Burner Parts	
Identification	27, 32
Ruby Orifice	23

Heating Elements

Schematics and Wiring ...	33-47
Specification Drawings ...	39-44

Innovator Refrigerator	3
Absorption System	1
Air Circulation	4

Installation Instructions	12
Built-in Dimensions	6, 7
12 Volt Wiring	6
Wiring Diagrams	33-37
Gas Connection	5, 11, 28
Installation Kits	6, 7

Leveling	8
----------------	---

Maintenance	12
-------------------	----

Operating Instructions	9
------------------------------	---

Operation Analysis (Gas) ...	8, 45
------------------------------	-------

Parts List	17, 30, 32
------------------	------------

Pressure Measurement	20
----------------------------	----

Replacing

Cooling Unit	22
Electric Selector Switch	25
Gas Line	23
Gas/Electric Control	
Assembly	25
Heating Element	38-42
Lamp Cartridge	29
Lamp Switch	26
Orifice	23
Thermocouple	23

Wiring Diagrams	33-47
-----------------------	-------

When ordering parts, please refer to model number and serial number of refrigerator.

The Absorption System Cooling Unit

Absorption cooling units have many configurations (see page 21) but they all use the same working principle to transfer heat from one place to another.

The refrigerant, designated R 717 (ANSI B79.1-1968), is a solution of ammonia and water ($\text{NH}_3 + \text{H}_2\text{O}$). To enhance performance, an internal pressure of 20 to 25 atmospheres of hydrogen (H) is added.

Heat applied or removed at various points in the system (see **Figure 1**) causes a change of state (*liquid to gas or gas to liquid*) of the refrigerant, but unlike mechanical systems, there are *no moving parts*.

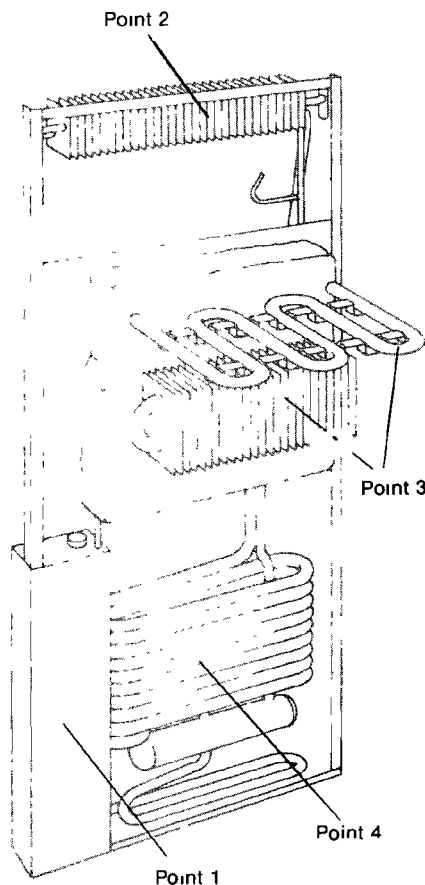

1

POINT 1 Generator-Boiler

Here a precise application of measured heat energy (*either gas or electric*) is applied. Refer to **Figure 1**, "Absorption Cooling Unit."

At point (A) a gas flame or at point (G) a resistance heat element causes the strong ammonia solution to boil. The rising ammonia vapor carries with it some weak ammonia solution through the system pump (*percolator*), point (B). The weak ammonia solution enters the smaller inner tube while the ammonia vapor enters the outer tube (D) where it passes down to point (E) through the strong liquid ammonia solution, picking up additional ammonia. It then rises through vapor tube (F) where remaining water runs back into the boiler and the dry ammonia vapor continues its rise to the system condenser.

POINT 2 Condenser

The system pressure at this point allows ammonia to condense at room temperature.

Here the condenser fins carry away some of the heat being transferred to the condenser tubes, thus lowering the temperature of the ammonia vapor enough to cause condensation.

The ammonia changes state (*from vapor to liquid*), and from this point (*the high point of the system*), gravity pulls the liquid ammonia (NH_3) down into the ammonia tube.

POINT 3 Evaporators

Pure liquid ammonia leaves the ammonia tube and spills into the low temperature evaporator (*freezer box coil*) where a large quantity of very light hydrogen gas creates an atmosphere around the pools of ammonia which permits the ammonia to boil off at low pressure and low temperatures. The more hydrogen and the less ammonia, the lower the temperature.

A portion of the liquid ammonia runs through the freezer box coil into the higher temperature evaporator (*secondary*) where it continues to boil at temperatures just below freezing. The heat required for this change of state (*boil-off*) is pulled away from the interior of the refrigerator and is carried away by the mixed ammonia-hydrogen vapor.

The mixed ammonia-hydrogen vapor, being heavier than hydrogen alone, settles downward to the absorber vessel.

POINT 4 The Absorber

As the ammonia-hydrogen vapor contacts the strong ammonia solution in the absorber, the ammonia goes into solution (*is absorbed*) and the very light hydrogen is freed to rise and return to the evaporators.

Heat liberated by absorbing the ammonia vapor is carried away by air passing over the outside of the absorber coils.

FIGURE 1. ABSORPTION SYSTEM FOR ...

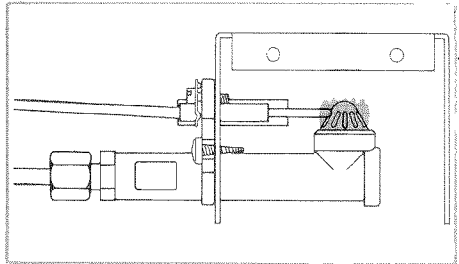
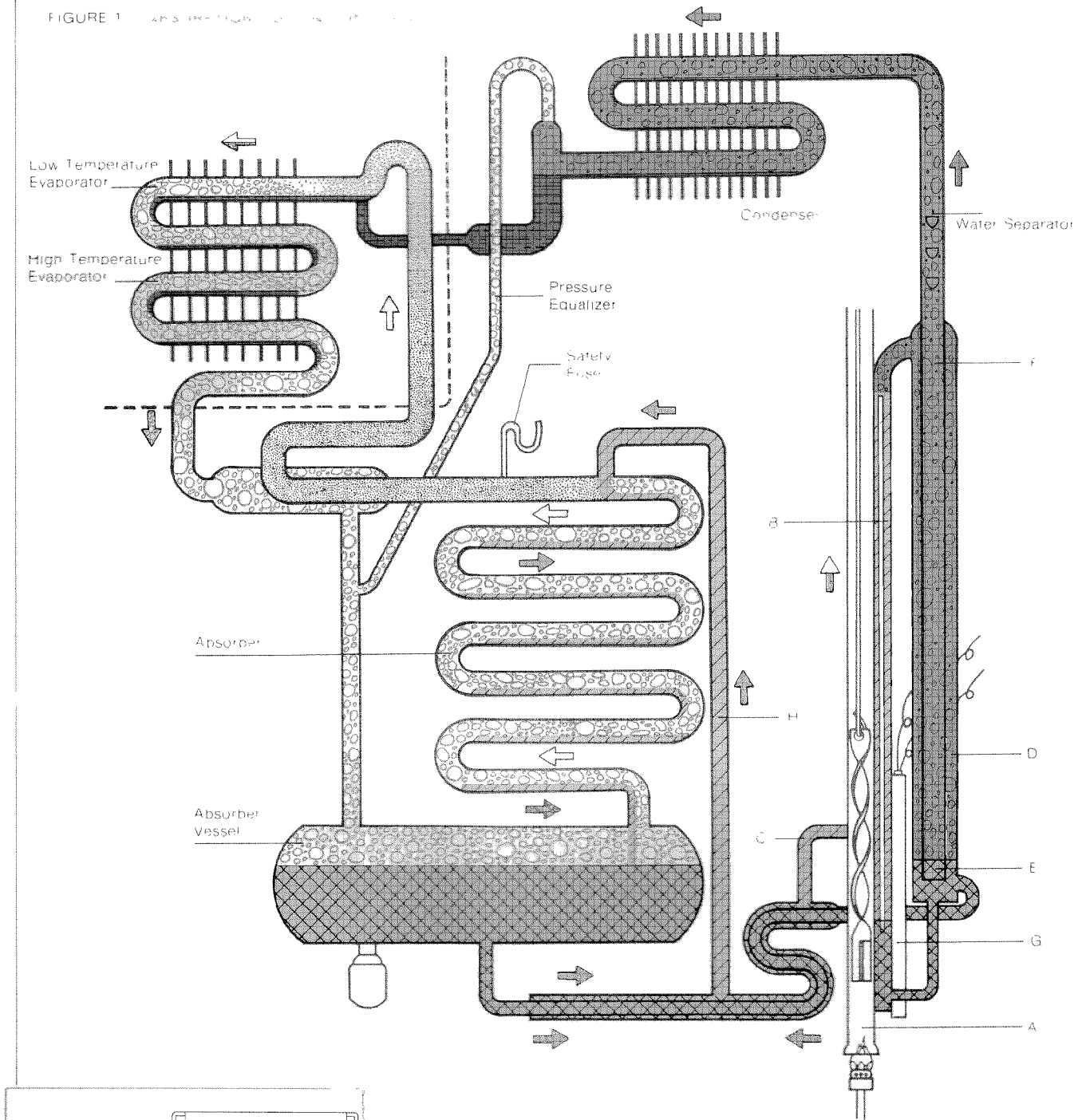

- | | | | |
|--|------------------------------|--|-------------------------|
| | Ammonia vapor | | Hydrogen gas |
| | Ammonia hydrogen mixed vapor | | Strong ammonia solution |
| | Weak ammonia solution | | Liquid ammonia |

The Innovator Refrigerator

Electronic ignition, automatic burner re-light, a 12V interior lamp, increased storage capacity, standard width and depth dimensions, removable food bins, interchangeable parts and components, service door servicability — all of these honor the name "Innovator"!

Home-like styling, color design coordination and advanced engineering techniques have been brought together to produce this modern, truly, functional refrigerator for a recreational vehicle owner or serviceman

Certifying agency standards have been faithfully kept in areas of safety and performance. Some of the new ideas built into the *Innovator* may well set future industry standards and some of the trouble shooting methods could be new to even the most experienced serviceman.

Considerable time can be saved by going through and becoming familiar with the trouble shooting techniques in this manual

A single thermostat and temperature sensing tube replaces the dual system used in most other refrigerators. The accuracy of this control, combined with a number of significant improvements in the burner, the cooling unit, and the cabinet, can maintain the relatively low temperatures to make ice or to safely store perishables

The applied principles of physics (*Dalton's, Boyle's, and Archimedes' Principles*) give the *Innovator* the potential to be the best in the industry

Whether or not it meets its full potential is in the skilled hands of the installers and service technicians.

The freezer compartment will normally maintain about 20° F (1° C) temperature below the average cabinet temperature when the ambient air is around 80° F (27° C)

This temperature difference increases or decreases normally with rise or fall of ambient temperatures

A careful study of the first section of this manual ("*The Absorption System Cooling Unit*") will explain why.

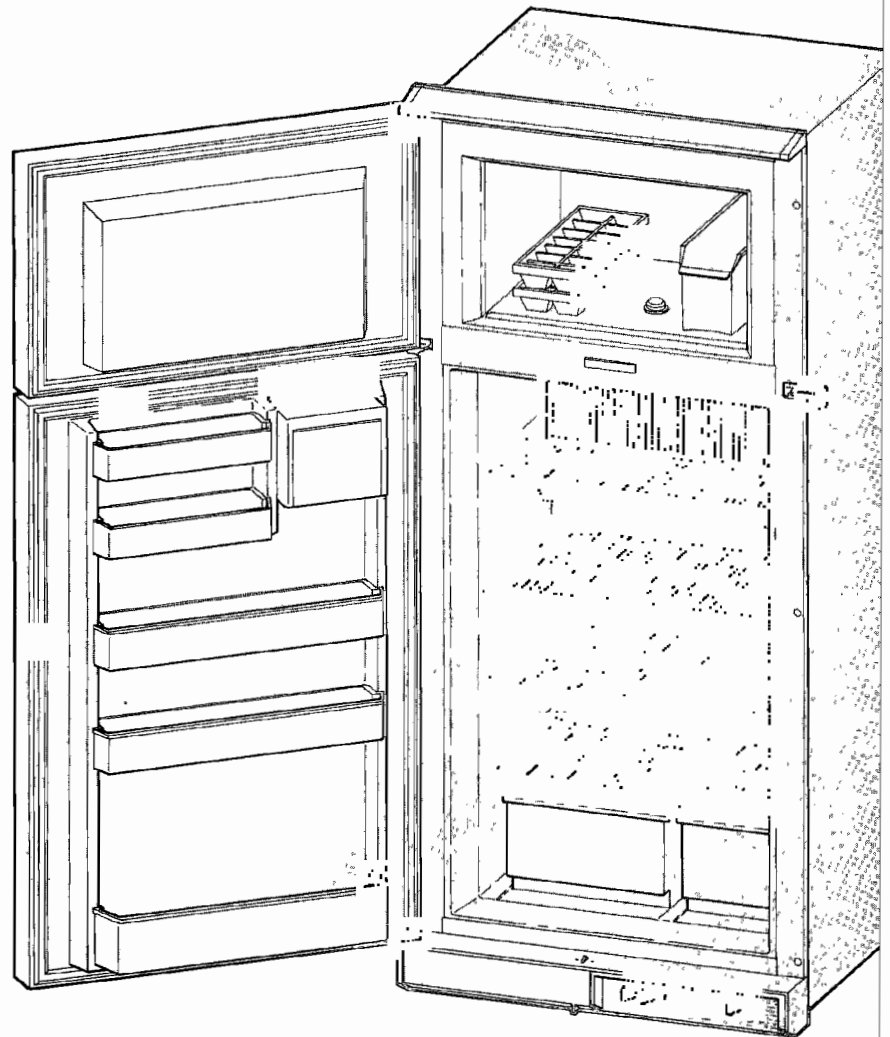

Innovator Air Circulation

Figure 2 shows the cold heavier air around the secondary evaporator coil (**Figure 1**) falling, picking up heat from stored foods, then being warmed and rising again to be re-cooled.

Please refer to "*Innovator Operating Instructions*" and drawings for adjusting the temperature in this food storage area.

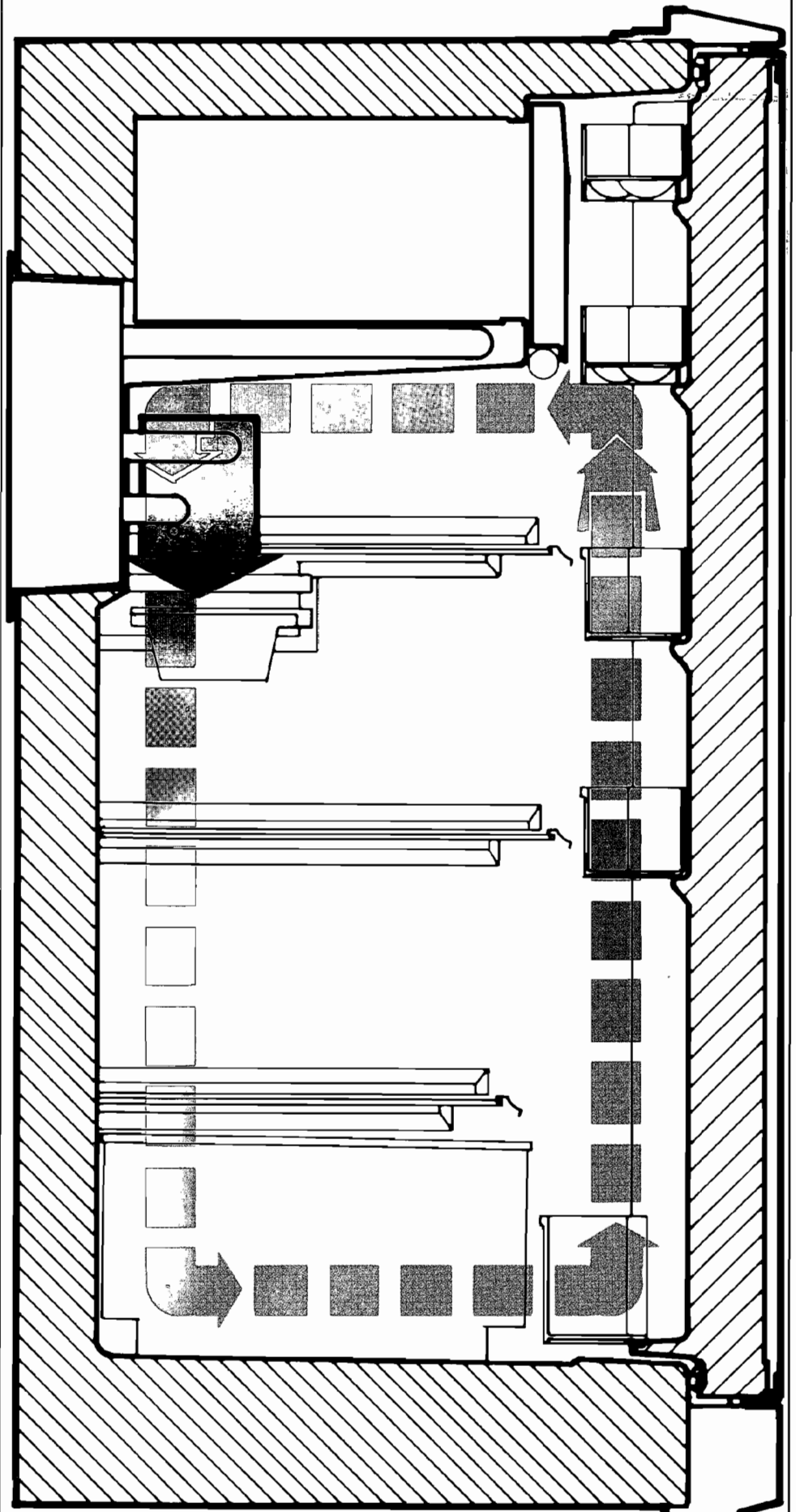

FIGURE 2 —
AIR CIRCULATION

Innovator Installation Instructions

IN GENERAL

Set the *Innovator* into a wall cut-out (see **Figs. 6** through **9** for proper dimensions). The *Innovator* must be installed on a solid floor and secured by running screws through holes provided in the rear support plate (from the service door) and through the holes provided in the cabinet molding

The method approved by certifying agencies for installation of the combustion air kit is shown for each model in **Figures 6-9**. Please note that the service door must be a #1422 rectangular door or a #1422R radius door (see **Fig. 5**). The roof vent must be a #620 (see **Fig. 4**). **There are no alternate vents, doors, or installation methods. Therefore, deviations can cause agency field inspectors to red-tag now approved items.**

Since the *Innovator* uses an absorption cooling unit, proper air circulation over the cooling unit is necessary for satisfactory performance. **It is essential that the *Innovator* be installed so that air behind and above the cooling unit is unrestricted.** The refrigerator cabinet must be enclosed at the bottom, sides, and top to eliminate pockets of air. All joints in the enclosure must be sealed tightly to prevent products of combustion from entering the living area.

THIS ANSI 119.2 REQUIREMENT MUST BE MET

Spaces between the *Innovator* and the cut-in recess must be positively sealed by molding, gasket (foam) tape, or other suitable materials

ABOUT GAS CONNECTIONS

The gas inlet elbow permits the recommended 3/8" copper supply line to come from either the right or the left without bending the tubing. **The gas supply line must be free of sharp bends or kinks** and should be installed so that it will not be damaged when the refrigerator is moved in or out of the recess.

LP GAS IS HIGHLY FLAMMABLE.

It is essential that all gas connections be tight and free of any leak.

Do not use a match to check for leaks.

This must be done in accordance with ANSI 119.2 standards or with a soap solution.

INSTALLATION PROCEDURE FOR INNOVATOR SERIES IM-40, IM-60, IM-70, AND IM-90

- 1 Cut recess opening to size of refrigerator shown in the appropriate installation diagram with approved zero clearance at sides, top, and back.
- 2 Install air vent kit supplied with refrigerator
See installation diagrams for dimensions and location
Vent kit must not be modified.
- 3 Make sure factory installed gasket tape (polyether or equal), 1/4" x 3/8", is in place and unbroken on the back side of the refrigerator cabinet molding, control box assembly and top cap assembly to assure combustion chamber is isolated from vehicle interior

THIS IS AN ANSI 119.2 REQUIREMENT

- 4 Inspect flue pipe for any foreign materials (spider webs, packing materials, etc.)
- 5 Set *Innovator* in cut-out and secure to vehicle by inserting wood type screws through pre-drilled holes in rear support plate from the service door opening and through the holes provided in the refrigerator cabinet molding into the recess opening studs
6. Connect gas supply, 3/8" copper tubing, to 3/8" male fitting on refrigerator. After installation, gas should be turned on. **USE LP GAS ONLY (11" water column manifold pressure).** All joints should be checked for gas leaks up to the burner according to ANSI 119.2 standards or with a solution of soap and water. Do not use open flame to test for gas leaks. Occasionally connections become loose during shipment or from vibration while in transit and this method of testing with soap should be done periodically on all the gas fittings. **If gas leak is found, turn off gas supply at tank and have problem corrected at nearest service center. The owner must not attempt to "fix" any gas leak.**

USE LP GAS ONLY.
Check for leaks using ANSI 119.2 standards or soap and water solution only.

All *Innovators* are factory tested for use on HD5 propane ONLY!

- 7 Connect 115 volt power using prong plug supplied by Instamatic in vehicle 115 volt receptacle.

NOTE: the following tag supplied by Instamatic must be left on all refrigerator 115 volt power cords.

WARNING Electrical Grounding Instructions

This appliance is equipped with a three prong (grounding) plug for protection against shock hazard. It should be plugged directly into a properly grounded three prong receptacle.

DO NOT CUT OR REMOVE THE GROUNDING PRONG FROM THIS PLUG!

- 8 Connect 12 volt power to terminal block on unit back. 2-way refrigerators require only a #18 AWG hook-up to the battery for the igniter and interior lamp circuit. 3-way refrigerators require a #1 AWG hook-up to handle the 1 volt heating element. See "12 Volt Wiring" for details.

NOTE: Any work involving gas piping, loose gas fitting, cracked or ruptured gas lines, etc., must be done by the RV manufacturer or by an authorized service center or dealer. If you feel that something is wrong with the gas pressure on the gas installation, go to your authorized service dealer.

The customer must never, never attempt any job that involves the loosening of ANY gas connection.

9. After putting the *Innovator* into operation, allow several hours before checking the cabinet temperature. Cooling time will vary with conditions (outside and inside temperature, humidity, exposure to direct sun, etc.). Whenever possible, the service door side of the RV should be shaded from direct sun exposure to enhance *Innovator* performance.

12 VOLT WIRING

For the 12 volt element in a 3-way *Innovator*, the installer must run wire heavy enough to handle the amp draw shown on the rating plate. A minimum #10 AWG stranded copper with 1/32" (30 mils rated at minimum 60° C) thermoplastic insulation (type MTW or equivalent) is necessary. Unless this high amp circuit runs through the vehicle ignition, **an automatic cut-out relay must be installed** to prevent power drainage from the vehicle battery when the engine is not running. A 25 amp in-line fuse is provided. If an RV fuse panel is also used, a 30 amp fuse *should be* installed in the panel, even though current should seldom exceed 21 amps.

A separate 12 volt internal circuit provided for the interior lamp and automatic igniter in the *Innovator* 3-way refrigerator. This circuit is marked on the 4-terminal block of the 3-way and is the only 12 volt circuit (2-terminal block) on the 2-way

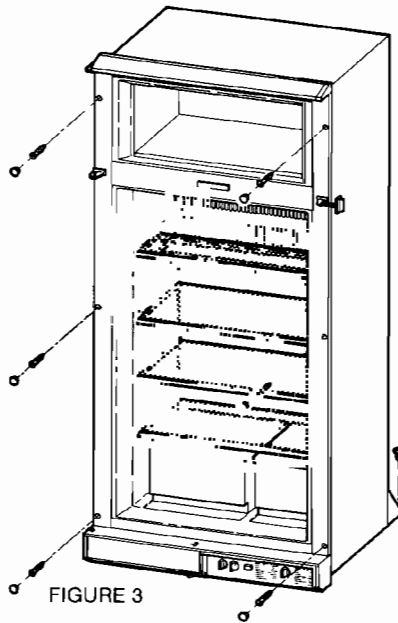

Innovator. Use a minimum #18 AWG supply wire for this low amp circuit (*less than 1 amp*) which may be fused but need not be run through the vehicle ignition nor an automatic cut-out relay.

NOTE: Do not try to operate refrigerator from a battery charger.

The output from a battery charger will not be sufficient for good operation.

NOTE: Before attempting any service on the refrigerator, be sure to **disconnect** both the 12 volt leads and the 115 volt plug.

Battery circuits furnished and installed by the recreational vehicle manufacturer and not part of the automobile ignition circuit do not require a cut-out relay. An over-current protective device (*circuit breaker or fuse*) must be provided however.

IM-42 — Use 18 gauge wire
 IM-43 — Use 10 gauge wire
 IM-62 — Use 18 gauge wire
 IM-63 — Use 10 gauge wire

IM-72 — Use 18 gauge wire
 IM-73 — Use 10 gauge wire
 IM-92 — Use 18 gauge wire
 IM-93 — Use 10 gauge wire

Minimum Built-in Dimensions

FIGURE 6
 INSTALLATION
 MODEL IM-40 SERIES
 Usable storage volume 3.7 cu. ft.

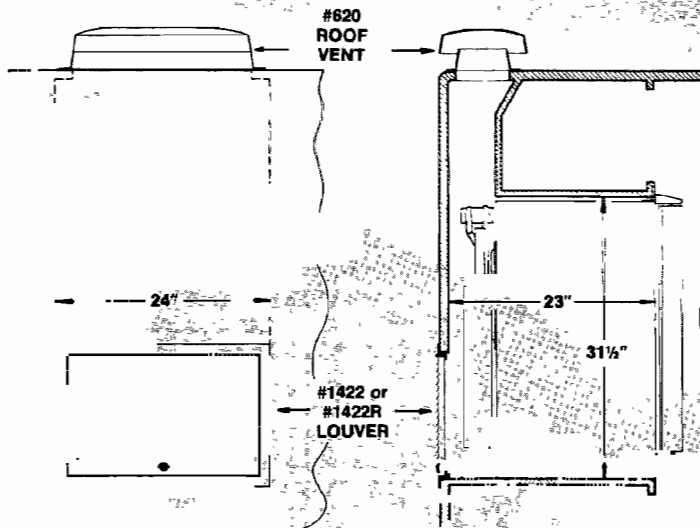
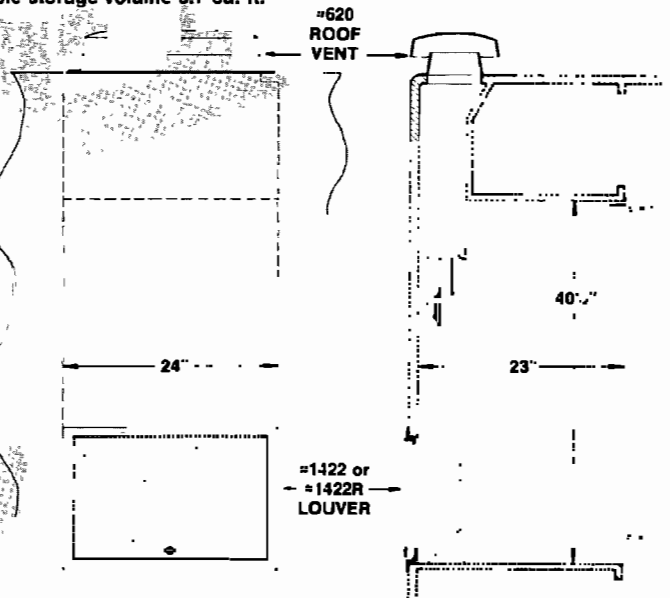
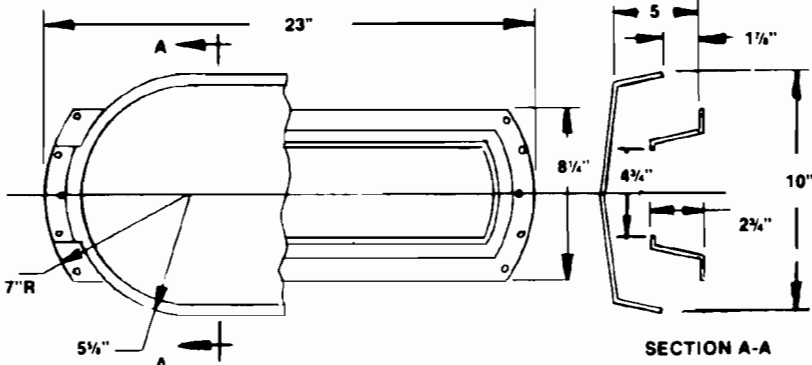
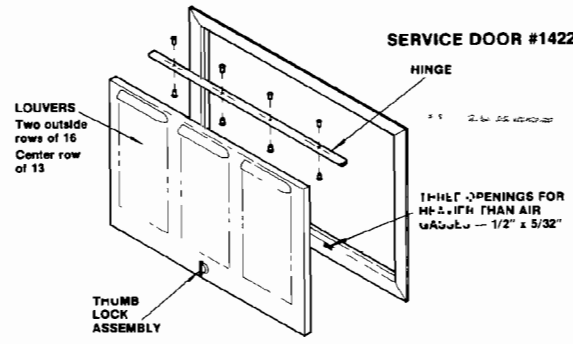

FIGURE 7
 INSTALLATION
 MODEL IM-60 SERIES
 Usable storage volume 5.7 cu. ft.





ROOF VENT #620
Cut out size 5 3/4" x 20 3/4"



RADIUS ACCESS DOOR #1422R

FIGURE 5

SERVICE DOOR #1422

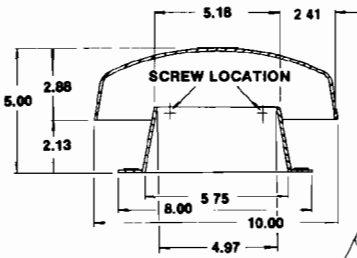
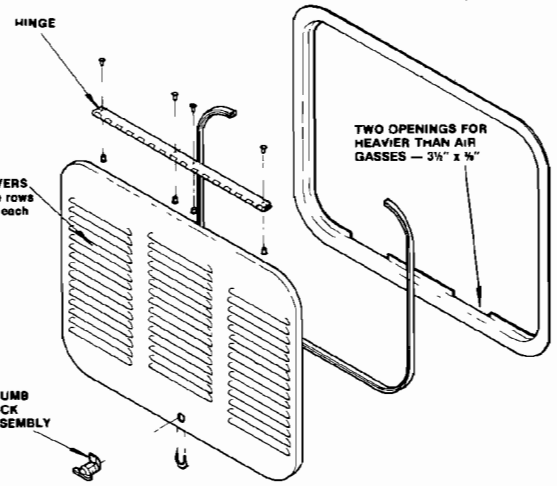
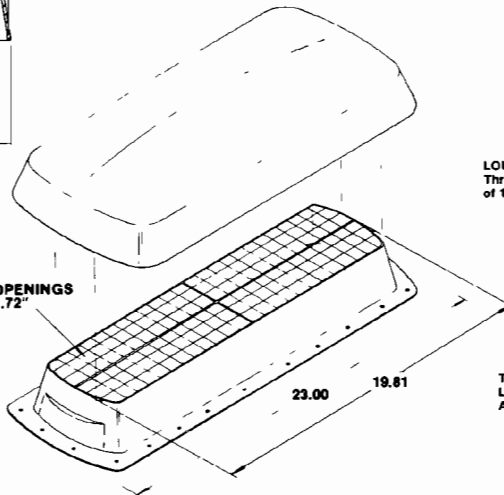

FIGURE 4 — #620 ROOF VENT

NOTE.
MATERIAL .094 THICK

144 VENT OPENINGS
.72 x .72"



RADIUS ACCESS DOOR #1422R

FIGURE 6
INSTALLATION
MODEL IM-70 SERIES
Usable storage volume 6.7 cu. ft.

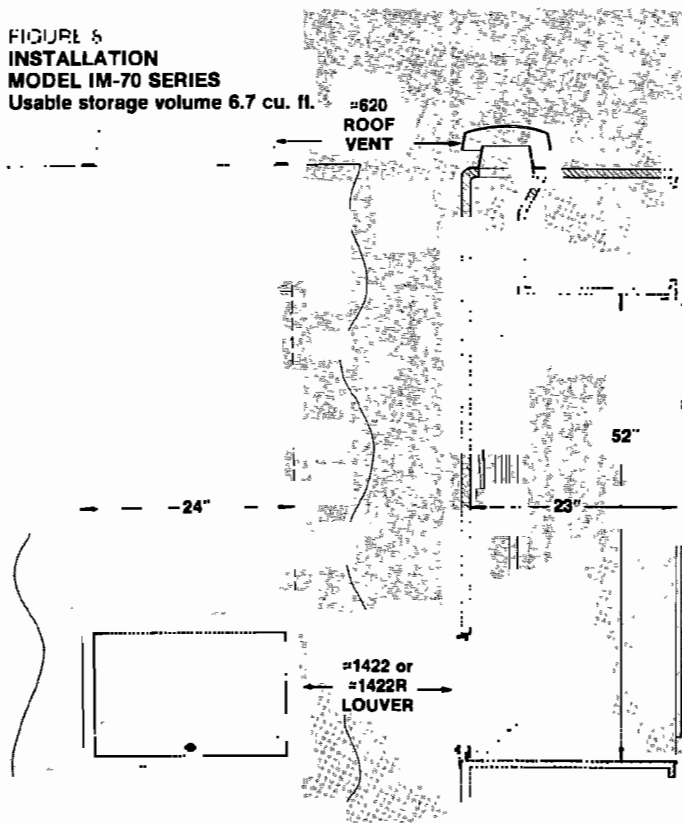
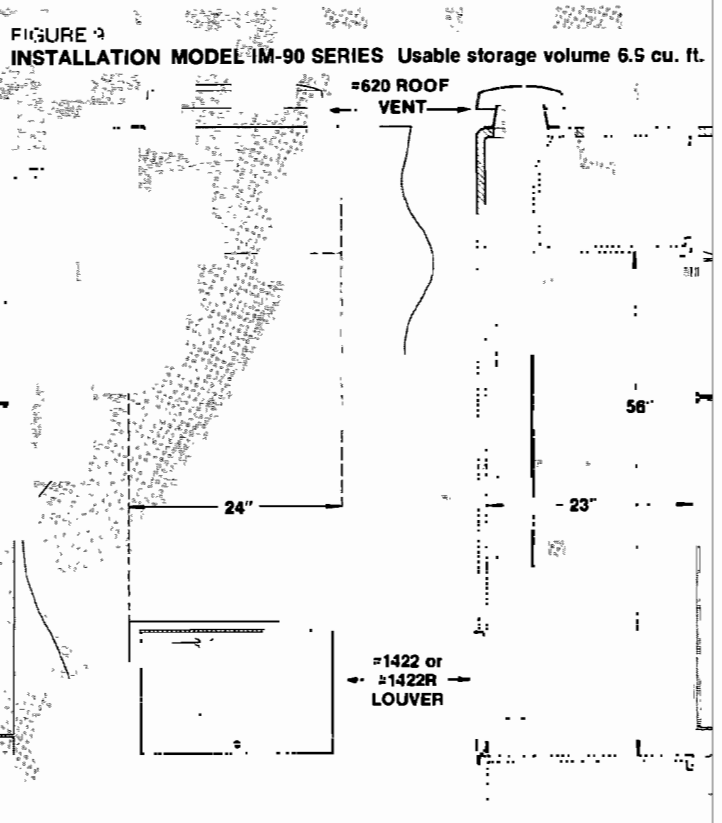

FIGURE 7
INSTALLATION MODEL IM-90 SERIES Usable storage volume 6.5 cu. ft.



Why Leveling?

Your new *Innovator* absorption refrigerator is powered by an LP gas flame or an electric heat element, permitting you to have silent refrigeration wherever you go. **In order for this to be possible and practical, certain conditions must be met.**

Cooling unit refrigerant uses heat and gravity as a source of circulating power. The heat generated by either gas flame or electricity circulates the refrigerant in the form of a vapor up through the condenser where it is changed to a liquid. From this point, it flows down through the freezing zone (or freezing plate) on its way back to the generator, completing the cycle.

When the liquid ammonia passes through the freezing plate it is again changed into a vapor by heat absorbed from the food and cabinet area. If the heat laden vapor is trapped or partially trapped by

FIGURE 10 — OPERATION SCHEMATIC

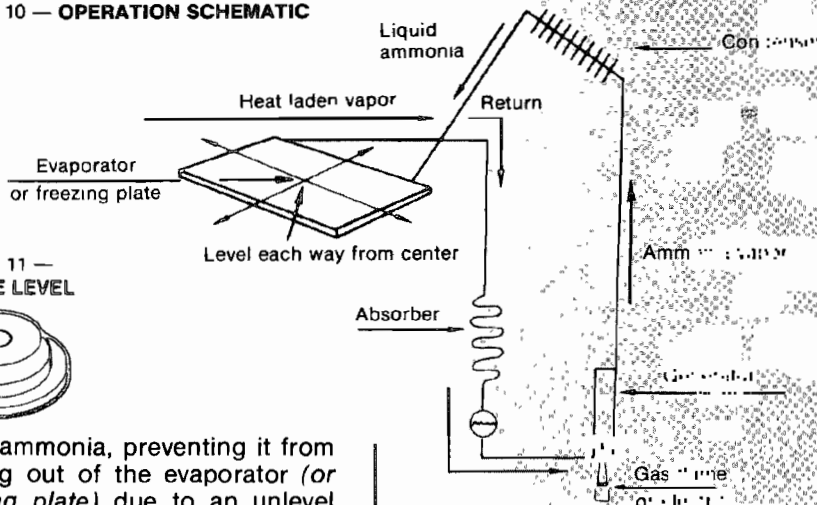
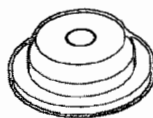

FIGURE 11 — BUBBLE LEVEL



liquid ammonia, preventing it from passing out of the evaporator (or freezing plate) due to an unlevel condition, the results will be a total or partial loss of refrigeration. For this reason, TAKE A LITTLE TIME TO LEVEL the freezing plate, using a small bubble level (see Fig. 10) and adjust the RV so that this point (center of freezer plate) is level side to side and front to back.

The refrigerator is normally installed with the freezing plate level in relation to the floor (center) of RV; if you find this true, then level the RV floor; if not, level from the plate.

IN-TRANSIT OPERATION

While the *Innovator* must be level when the RV is parked, it will perform under temporarily off-level conditions in transit.

When the RV is moving, a washing action caused by the motion will prevent any liquid from trapping this vapor on its way back to the generator for recirculation. In addition, traveling creates more air circulation for the air cooled unit, resulting in improved performance.

Tips on Cooling Unit Analysis

Your *Innovator* has been engineered to give long, trouble-free duty. It is therefore obviously important that all external factors affecting performance be checked thoroughly before any part is condemned as faulty — especially the cooling unit.

Emphasis has been placed on good and proper installation and leveling. Just as important are things like correct heat input, clean flue tube and clean and unrestricted top cap and service door louvers. All *Innovators* carry the wattage rating and gas BTU input for each unit. **Note: gas pressure must be 11" w.c.**—higher or lower gas pressure will change performance on gas. Wattage is based on 115 volts plus or minus 5%. Greater variations in voltage will affect performance on electricity. The ruby gas orifice is laser drilled to give an infinitely smoother bore which won't pick up the dirt common to a drilled brass orifice. Any attempt to enlarge the ruby orifice will crack the ruby and make replacement necessary. As a rule, the ruby orifice should never need changing unless it has been abused

—and the size should never be changed with the idea of enhancing performance.

Make certain electrical element(s) are inserted to the bottom of the well or to the stop provided on some brands of elements. Improper positioning, like improper gas input, will cause improper vaporization of ammonia in the boiler. Ultimately this may cause the liquid mixture in the boiler to become weak, resulting in the system pump malfunctioning. When the circulation of liquid ammonia slows or stops it may seem that the cooling unit is defective; when in fact the culprit may be one or more of the above. If the vapor pipe from the boiler to the condenser becomes very hot (sometimes the paint will blister or metal will be discolored) the serviceman can be sure of a system blockage — probably caused by improper heat, operating in an off-level position, inadequate ventilation or direct sun in very high ambients.

Good and proper analysis takes time, but it may well save time and money in the long run. The *Innovator* should be run a minimum of

eight to twelve hours at the "coldest" thermostat setting prior to examination by the serviceman. This can be arranged by telephone when the service appointment is set up or when the service order is written for "drive in" customers. After the *Innovator* has been operating for about eight hours, the cooling unit should stabilize. The absorber coil should be warmer at the bottom than at the top. The absorber vessel will be slightly warmer. The vapor pipe from the boiler to the condenser will be hot, but bearable to the hand where it joins the condenser, becoming hotter as it moves toward the boiler.

Summary— before condemning a cooling unit:

1. Check wattage or gas input (see rating plate).
2. Check for proper electrical element position.
3. Check gas flame characteristics (sharp blue).
4. Check flue for spider webs, carbon, obstructions.
5. Check service door and roof vent for blockage.

Innovator Operating Instructions

LEVEL

After the RV is parked, make sure your *Innovator* is level (see page 8), "Why Leveling?" for explanation). Use the small bubble level provided for this purpose (Fig. 11).

SHADE

A good rule for best *Innovator* performance, park your RV so the *Innovator* service and vent areas are shaded from direct afternoon sun. Excessive solar load can have an adverse effect on performance.

CONTROLS

A 2-way *Innovator* has two control knobs and a 3-way has three knobs. Located behind a sliding door at the base of the *Innovator*, all controls are accessible without opening the refrigerator door. A single thermostat knob regulates temperatures for either gas or electric operation by turning clockwise 330° from defrost to coldest setting. Factory calibration gives 3° to 5° differential between on or off on electricity and full on or bypass on gas.

The gas/electric control knob—just to the right of the thermostat—rotates 90° each way from the horizontal (off) position. **Depress** and turn 90° clockwise for electric operation. **Depress** and turn 90° counter-clockwise for gas operation.

On 3-way *Innovators*, a rotary selector knob must be set at either 12V or 115V.

The flame meter replaces peep holes, prisms, etc. to indicate a flame has been established by the automatic igniter during gas operation.

START UP

Gas Operation

1. Make certain 12V power is available at terminal block for electronic ignition and interior lamp.
2. Turn on gas supply at tank.
3. Depress and turn gas/electric control 90° counter-clockwise to "gas" position.
4. Hold in depressed position until flame meter needle moves into green area.
5. "Ticking" of automatic igniter should stop. Release knob.

NOTE: Air in the lines may cause flame to extinguish long enough to break magnetic safety—repeat steps 2, 3, and 4.

6. Turn thermostat clockwise to coldest position for the first few hours of operation.

Electric Operation

1. Make certain power is available through 115V power cord and the 12V wires to the terminal block on back of *Innovator*.
2. For 3-way *Innovators*, set 12V/115V selector in proper mode.
3. Depress gas/electric selector switch and turn 90° clockwise to electric position.
4. Turn thermostat clockwise to coldest position for the first few hours of operation.

IMPORTANT RECOMMENDATION 12 volt operation should be used only in transit

Before leaving home, plug in RV utility cord and operate *Innovator* on 115 volts (or LP gas if preferred) about 8 to 12 hours. The unit will be cold and may then be switched to 12 volt operation for highway use.

At destination, *Innovator* may be switched back to 115 volts or LP gas.

OPERATIONAL SWITCHING

To change from 12V to 115V to gas operation, use the same procedures outlined under "Start Up." Make certain all controls are set the proper position and that power connections are made. Power must be available to the automatic igniter and lamp circuits (see wiring diagrams, pages 33 through 37 for gas operation and page "12 Volt Wiring" for complete instructions).

ICE MAKING

Rapid ice cube production is possible when the thermostat is in coldest position (full clockwise 9). Because of the time normally required for ice making, an ample supply of ice cubes should be stored in the trays ready for immediate use. If frozen foods are to be stored in freezer compartment, thermostat may be kept at or near the coldest position.

Freezing of foods stored near back of the upper shelves below freezer will require turning thermostat to a slightly warmer (counter-clockwise) position.

DEFROSTING

Never use a hair dryer or other heat-producing appliance to hasten defrosting. Filling the ice cube trays with hot water will minimize defrost time and prevent heat build-up in stored perishables.

Defrost at regular intervals whenever heavy frost build-up is noted. Thermostat should be in "defrost" (full counter-clockwise) position. As soon as front mirror wipe all moisture from freezer interior parts and turn thermostat "coldest" (full clockwise) position. Careful attention to this simple maintenance procedure enhances *Innovator* efficiency.

Refrigerator Care and Maintenance

CLEANING

The best time to clean the cabinet interior is while the *Innovator* is defrosting. After removing all stored foods, wash with lukewarm water to which a small quantity of mild household detergent has been added.

Never place removable components in a dishwasher and never use abrasives, steel wool, or scouring powder.

Rinsing in a solution of baking soda and water will freshen up areas which have had food spills. Wipe with a soft dry cloth to minimize water spotting.

Regular attention to this normal household chore will assure the fresh taste of stored foods and can minimize food stains on interior components.

When *Innovator* is NOT in use, it is recommended that the interior be cleaned and that the door be left open until all components are dry in order to prevent growth of odor-causing bacteria.

STORING FOOD

- 1 Proper refrigeration requires *free air circulation* within the food storage compartment. *Restricted air circulation* within the food storage compartment will cause higher cabinet temperatures. **Rearrange foods (Fig. 2, page 4)**
- 2 It is also essential that the shelves are *not* covered with paper or large storage containers.
- 3 Odorous foods or highly flavored foods should *always* be stored in covered dishes, plastic bags or wrapped in foil or waxed paper to prevent food odors. Vegetables, lettuce, etc., should be *covered* to retain their crispness. **Never put hot food into the refrigerator.**
- 4 To reduce frost formation in and on the freezing compartment, cover stored liquids and moist foods and *do not* leave the door open longer than necessary.
- 5 When the refrigerator is heavily loaded, it takes longer for refrigerator temperatures to lower, requiring a much longer time for ice-making. A very heavy load may also cause unplanned defrosting.

ICE CUBES

Do not use warm water. Faster freezing will result if precooled water is used.

TRAVEL LOCK

The travel lock **must be** fitted to hold the door closed while in transit.

GASKET SEALS

- 1 For correct operation, it is essential that the door gasket makes a good seal all around, against the front of the cabinet.

The compression of the gasket, down the hinge side, must not be too great. The gasket should just contact the front of the cabinet when the door is closed. This is normally allowed for during manufacturing.

Failure of the door gasket to contact the front of the cabinet may be determined visually when the door is closed. Run a "dollar bill" along the door seal, inserted between the seal and the cabinet front. Nowhere should the bill feel loose. Replace gasket if necessary.

- 2 *Innovator* has integral door alignment, making a good door seal more positive. Positioning hinge fixing screws has been eliminated.
- 3 It is also essential to make certain that the cabinet opening through which the evaporators enter the cabinet are properly sealed by a gasket or sealing compound. If these seals leak, warm air enters the cabinet, causing high cabinet temperatures and excessive frost formation in the freezing compartment.

FLUE OBSTRUCTIONS

On gas operation, the flue normally requires occasional cleaning. To do this it will be necessary to gain access to the back of the cabinet. When cleaning the flue, proceed as follows:

Completely remove refrigerator. Then remove burner box and cover the entire burner assembly with a piece of foil and lift out the baffle on its support wire from the top of the boiler tube. From the top, clean the flue with a suitable flue brush. Clean baffle before replacing.

NOTE:
Some cooling units DO NOT use a metal twist baffle.

An obstruction in the flue will reduce or stop flue draft. Flue obstructions will cause odors outside the refrigerator, slow freezing and higher cabinet temperatures. Flue blockage may also cause the flame to burn outside the flue tube. Refer to "Odors from Fumes."

ODORS INSIDE THE REFRIGERATOR

Odors inside the refrigerator are caused by improper food storage. See "Storing Food" (page 10). Odors may also be caused by too infrequent cleaning of the food compartment or from the refrigerator being shut off for some time with the door closed.

ODORS FROM FUMES

1. Odors outside the refrigerator may be caused by gas leaks. Make sure that all shut-off valves on all gas appliances are closed. Test gas connections and all joints in the gas line with soap and water solution.

Never look for a leak with an open flame.

Use a flashlight when necessary in looking for soap bubbles caused by leaks. The gas line should be free of kinks and sharp bends. Turn on gas valve, light burner and test connections

between the gas valve and the burner carefully with soap and water.

2. Odors outside the refrigerator may be caused by improper burner flame.
3. Flame touches side of the boiler due to dislocation of the burner. **Relocate.** Burner dislocation may also cause smoking, and sooting.
4. Burner damaged. **Replace.**
5. Flame touches the flue baffle. **Correct position of baffle.**
6. Flue tube is dirty. **Clean the flue.**

LOST THERMOSTAT CHARGE

Sometimes the electric control switch may appear to be faulty. If the thermostat sensing tube is filled with inert gas. When the tube is ruptured, the thermostat loses its charge and will become inactive. If the charge is lost, the burner flame will remain on minimum or the unit will not perform on electricity regardless of the control knob position! Proceed as follows for the test: *After removing the sensing tube from tube retainer in the evaporator, warm up the tip (approximately 3") of the capillary tube by holding it with fingers. If the flame fails to enlarge or, the electric heating element fails to operate, the thermostat has lost its charge. AND the entire Sourdillon Control MUST BE REPLACED!* See page 25.

SERVICE HINTS FOR BURNER

If the burner flame extinguishes when the thermostat is set to reduce the flame to a very low or by-pass flame.

1. The tip of the thermocouple is located too far away from the flame. Check mounting screws of the burner bracket; make corrections, or replace with a new one.

2. The connection between thermocouple and the control knob is not tight enough. For correct connection, a torque range from **20 to 25 inch/pounds** is recommended. See page 23.

IMPORTANT: The tips of the thermocouple and the automatic ignition tip must be set at the burner head.

In case the attempt at burner lighting has to be repeated because of lighting failures:

1. See Start-Up, page 9.
2. See Innovator Trouble-Shooting Chart, page 24.

IMPORTANT: The tips of the thermocouple and the automatic ignition device are factory set at the same level and point to the top of the burner head. **Field adjustment will almost never be necessary.**

BURNER ORIFICE CLOGGED

Should the ruby burner orifice become clogged, the flame will decrease on the maximum setting of the thermostat and will affect burner heating output and result in a decrease of cooling efficiency.

REPLACE RUBY ORIFICE (page 23). **Never attempt to clean the ruby orifice with a wire device which will crack the ruby.**

BURNER ORIFICE

The ruby orifice size is designated by the number stamped on the back of the orifice as follows:

Model	Orifice
IM-40 Series	32
IM-60 Series	37
IM-70 Series	37
IM-90 Series	415

General Maintenance Instructions

TROUBLE SHOOTING

If your refrigerator is not working properly, check the **Trouble-Shooting** hints listed on pages 24, 45, and 46.

If your refrigerator still fails to operate, turn it off at the on/off knob and electric on/off switch and contact Instamatic immediately, giving the model number and the serial number shown on the nameplate and complete details of your troubles. *Try to diagnose the problem and avoid the word "defective."*

IMPORTANT:

Repair of the Innovator refrigerator must be performed by an authorized service point or selling dealer.

Tampering with any part of the refrigerator by unauthorized personnel will automatically void the warranty.

FLUE CLEANING

An obstruction in the flue will reduce flue draft and can result in higher cabinet temperatures and faulty operation. It is advisable to clean the flue at least once each year so that it will be kept free of dust, spider webs, and soot.

It will be necessary to gain complete access to the back of the cooling unit by pulling the *Innovator* from the RV. Proceed as follows:

Remove the metal burner housing and cover the burner assembly with a rag so that loose dirt will not fall into the burner. Remove the flue baffle* by lifting on the baffle support wire until it is out of the flue tube. From the top, clean the flue with a suitable wire brush. Clean the baffle before replacing.

* Some cooling units do not have an internal baffle.

Should an orifice of a different size be substituted, cooling efficiency will be affected and may cause cooling unit failure, and will void the cooling unit warranty.

The ruby orifice is laser-drilled and **CANNOT** be modified or changed. Use of any wire-like device to clean or enlarge the orifice will result in breaking the ruby.

IMPORTANT

The refrigerator must be inspected periodically and before reuse after shut-down.

1. Check all gas connections for possible leaks using a solution of soap and water.

(Do not use a lighted match.)

2. Inspect the flame for color. It should have a sharp blue cone and mantle—NOT YELLOW. Check for a high and low flame. This can only be observed after several hours of operation.

3. Check the interior of the flue tube for possible soot deposits. Remove flue extension tube by removing bracket and removing the flue baffle. Clean inside of flue tube with a wire brush and reassemble parts.

Flue Assembly

The dimensions of the flue and the flue baffle have been engineered to give best possible efficiency and meet A.G.A and C S A standards

The baffle distributes the heat produced by the burner and enhances the draft, providing primary and secondary air to the burner.

The sizes and distances differ with each cooling unit. It is important that these factory dimensions be maintained to insure proper performance and safety.

Burner must be perfectly aligned so that flame never impinges on any part of the flue tube or burner box assembly.

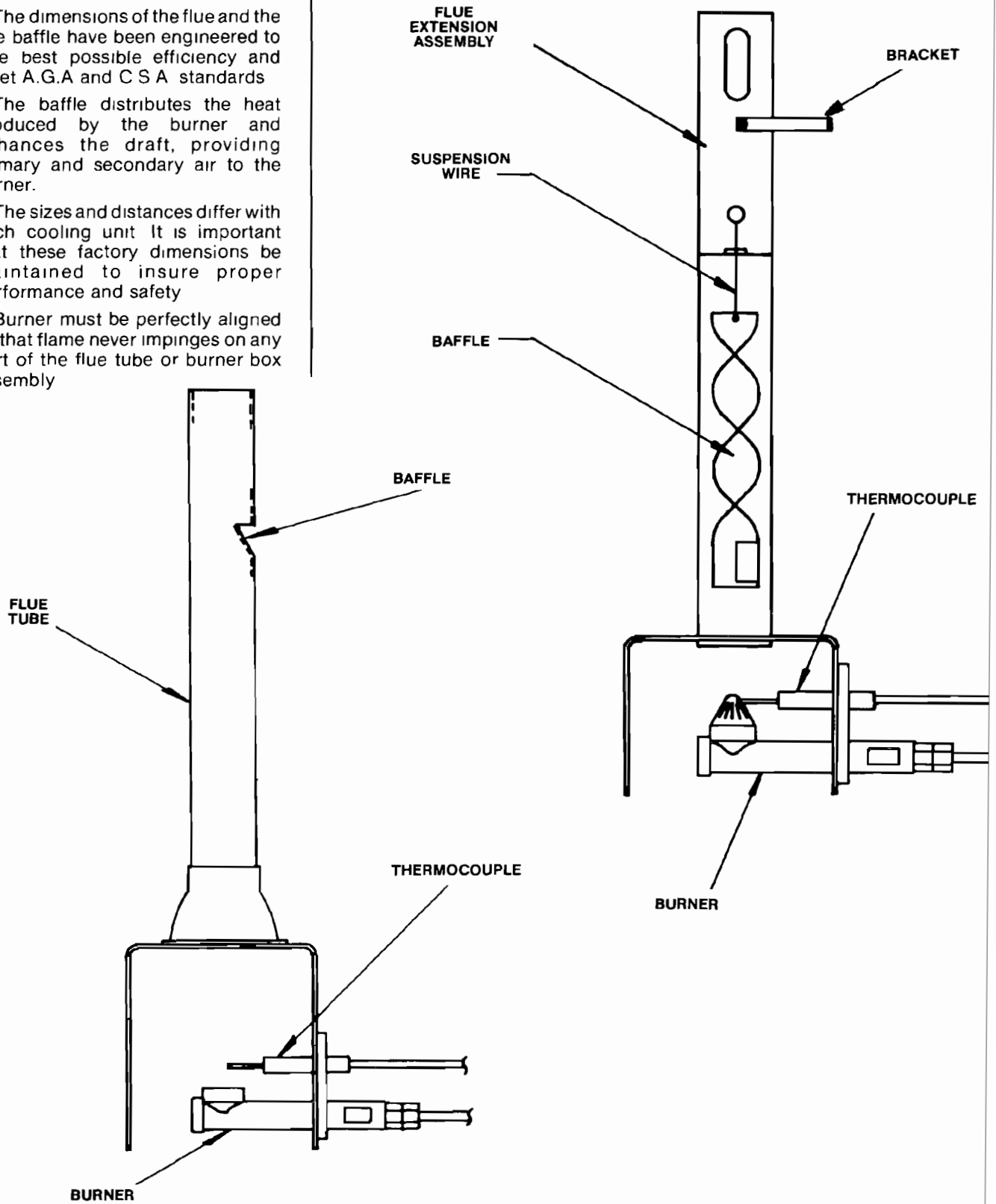

FLUE ASSEMBLY

Changing Decorative Panel

As easy as

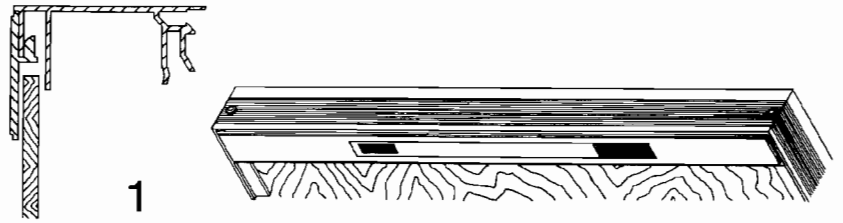

1

FIGURE 12 —
THE EASY 1-2-3 WAY
TO CHANGE YOUR
DECORATIVE PANEL

Lift bottom of trim strip
slightly away from panel.

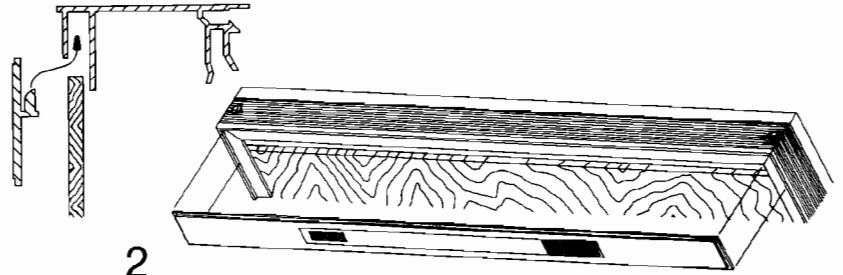

2

Pull trim strip down and away.

3

Slide out old panel; slide in
new panel.

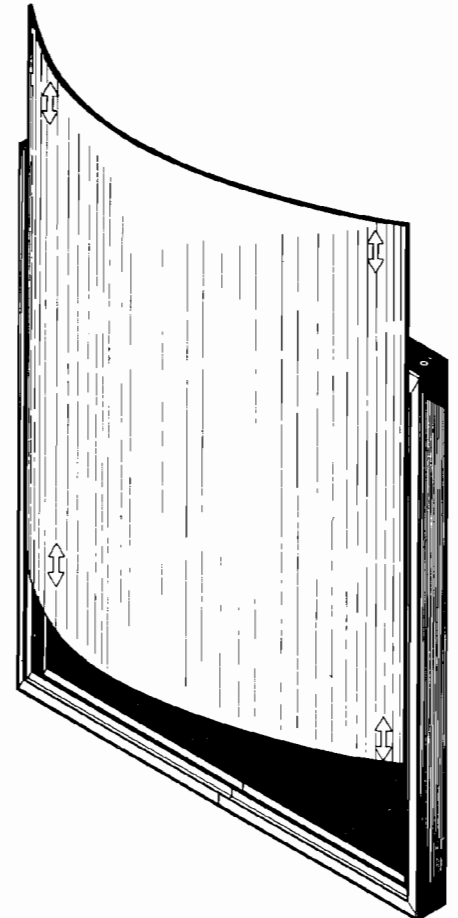

INNOVATOR DOOR PANEL SIZES

Model	Wood Panel*	Metal Panel†
IM-40	26¼ x 24½	26½ x 24¾
IM-60	35¼ x 24½	35½ x 24¾
IM-70 Freezer	9½ x 24½	9¾ x 24¾
IM-70 Lower	35¼ x 24½	35½ x 24¾
IM-90 Freezer	35½ x 24½	35¾ x 24¾
IM-90 Lower	35¼ x 24½	35½ x 24¾

* Wood panel is 5/32" plywood.

† Decorative metal requires ¼" foam tape strips on back.

NOTE: All tolerances ± 1/16"

Changing Door Swing From Left To Right

The door hinges on the *Innovator* have been designed to permit opening either to the right or left.

To change the door swing:

1. Remove end cap holding screw (Figure 13). Part number A4-320022-011. (If your *Innovator* has screws remove them!)
2. Remove both top end caps grasping firmly and pull away from top panel.
3. Unscrew top hinge pin.
4. Lift door off lower hinge.

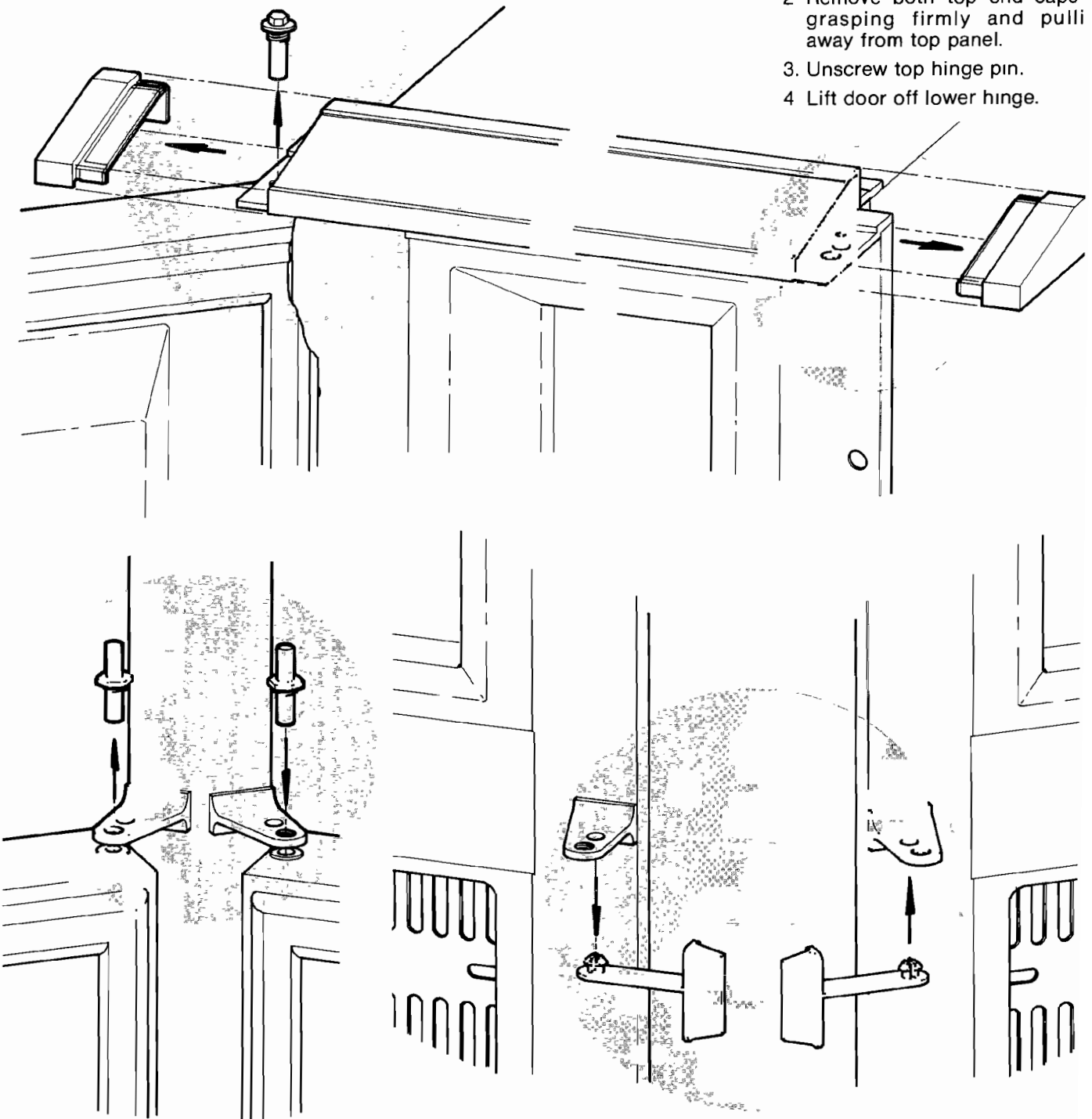

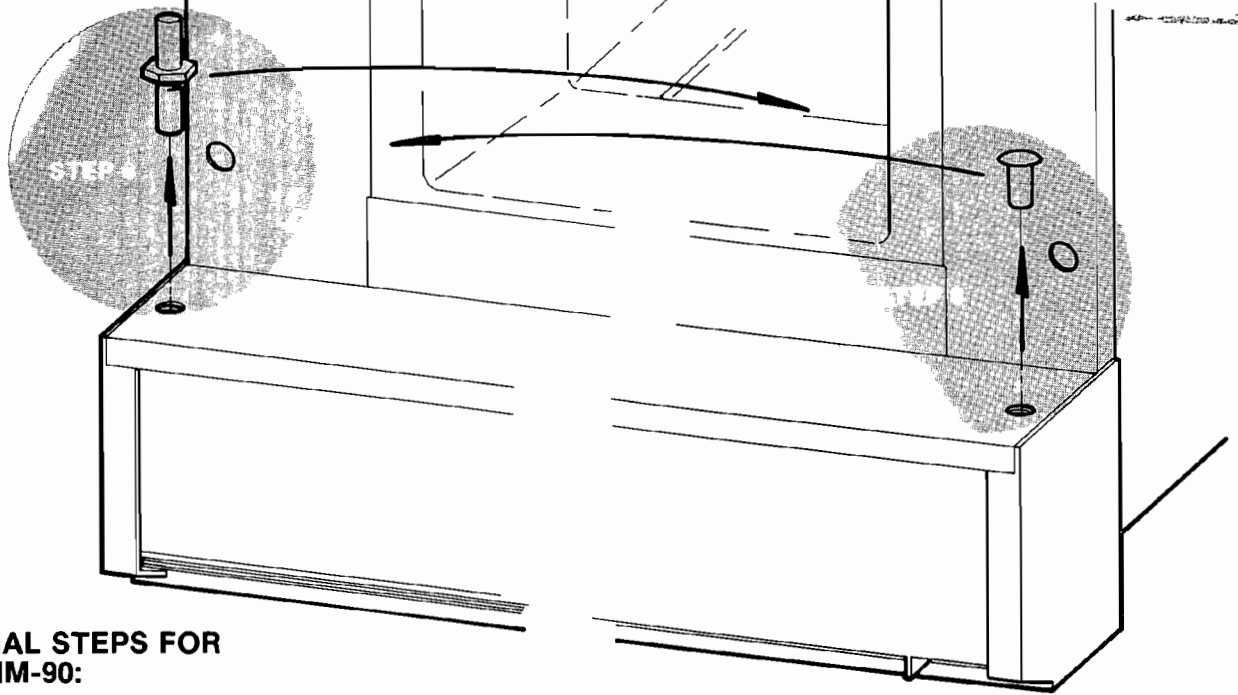

ADDITIONAL STEPS FOR IM-70 OR IM-90:

Lift off freezer door from center hinge on IM-70 or IM-90. Unscrew center hinge pin, lift off lower door. **See step 6** to reinstall lower door. Replace center hinge pin to secure lower door.

5. Pop out travel lock and reinstall on opposite side.
6. Unscrew lower hinge. Pop out plastic plug and reinstall on opposite side.
7. Set door on lower hinge and reinstall top hinge pin to hold the door in place.
8. Replace both top end caps.
9. Replace end cap holding screws.

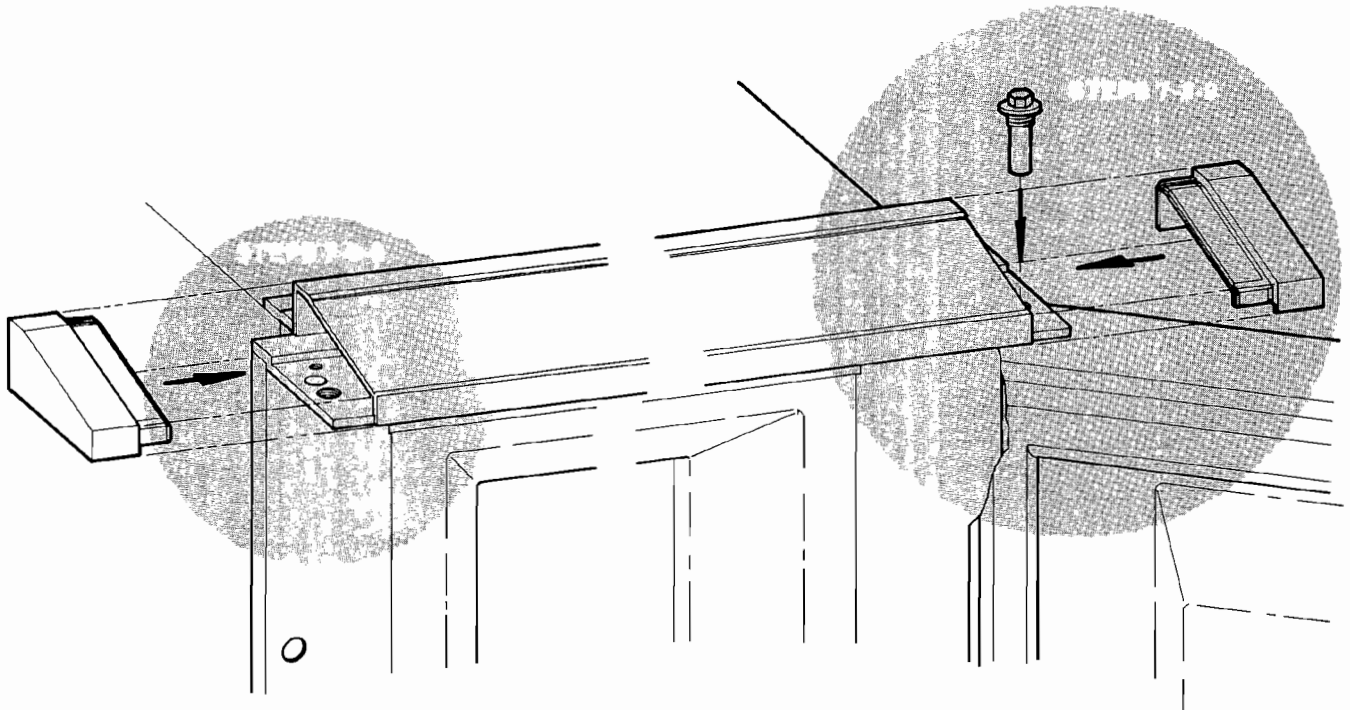

Replacement of Freezer Door on the IM-40 and IM-60

- 1 Push carrier ("A") inward by means of a blunt mandrel or pin (**Fig. A**) and remove the shutter.
- 2 Pry the spring housings ("B" in **Fig. A**) away from the lining so that it snaps out and turn the spring housings down 180° (**Fig. B**).
- 3 Mount the new shutter in close position first on one side, making sure that the cross slots engage in the cross on the hinge plate ("C" in **Fig. A**).
- 4 Press the carrier on the opposite side so that the hinge plate on the shutter can be pushed over it. See that the crosses engage.
- 5 Turn the spring housings round and up until the small tag ("A" in **Fig. B**) snaps into the slot in the lining.

NOTE: Illustration is for right hand hinge—both left hand and right hand assemblies are used

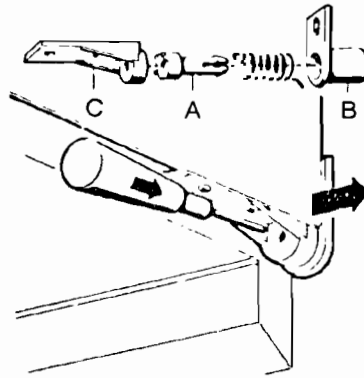

FIGURE A

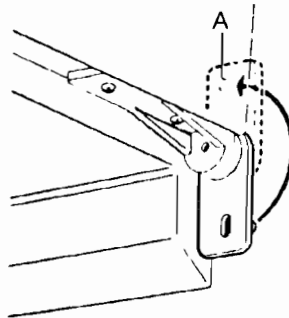
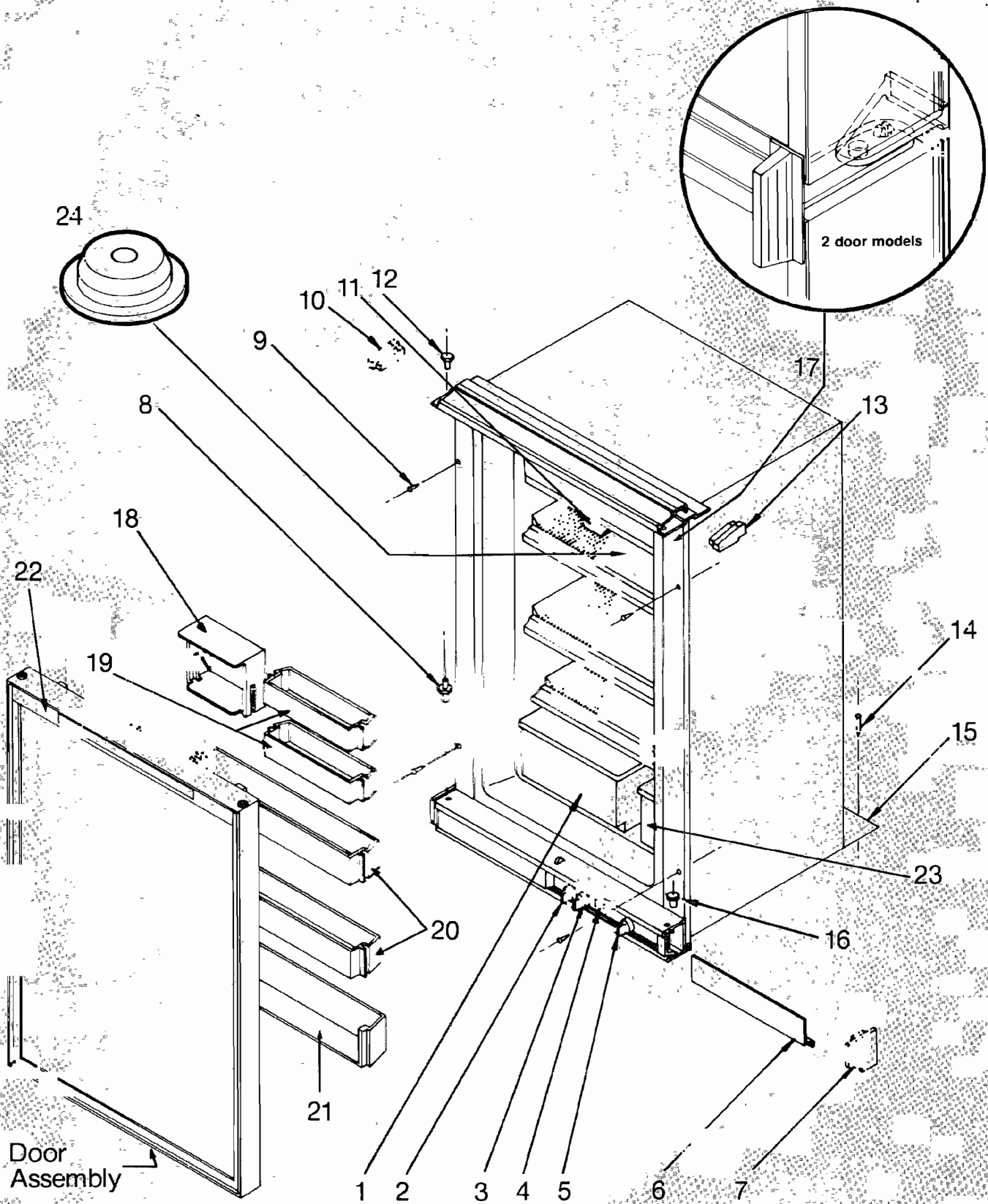

FIGURE B

1. Vegetable Tray Large*
2. Thermostat Control Knob
3. Gas Electric Selector
4. Flame Meter
5. 12V 115V Electrical Control Knob
6. Control Cover
7. R. H. End Cap (Bottom)
8. Hinge Pin (Bottom)
9. Mounting Screw (Side Molding to Cut-Out Surface)
10. L. H. End Cap (Top)
11. Lamp Assembly
12. Hinge Pin (Top)
13. R. H. End Cap (Top)
14. Mounting Screw (Rear Support Plate to Floor)
15. Rear Support Plate
16. Plastic Plug
17. Travel Latch
18. Butter Box Assembly
19. Egg Tray (2)
20. Small Door Shelf
21. Bottom Door Shelf
22. Door Trim and Decal
23. Vegetable Tray Small
24. Bubble Level

*Optional items on some Innovators

FIGURE 11
INSTAMATIC INNOVATOR PARTS
Available from Elkhart plant or
western branch in California



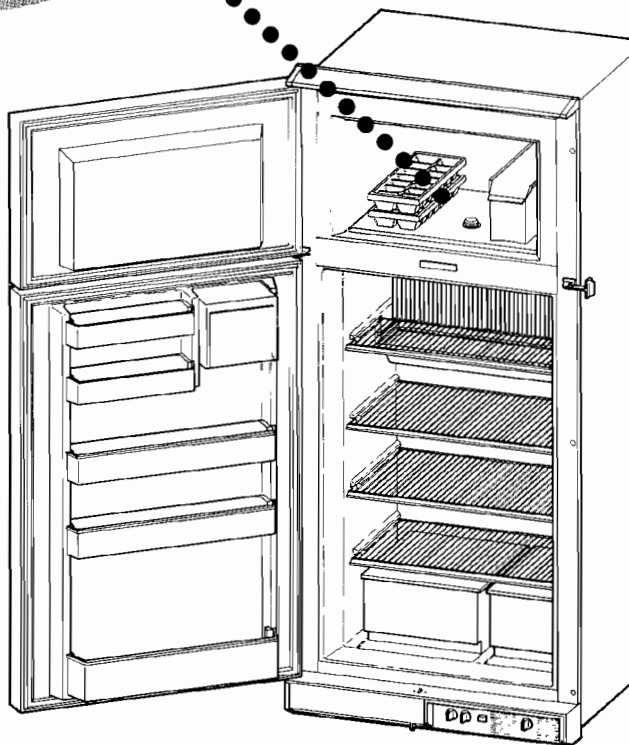
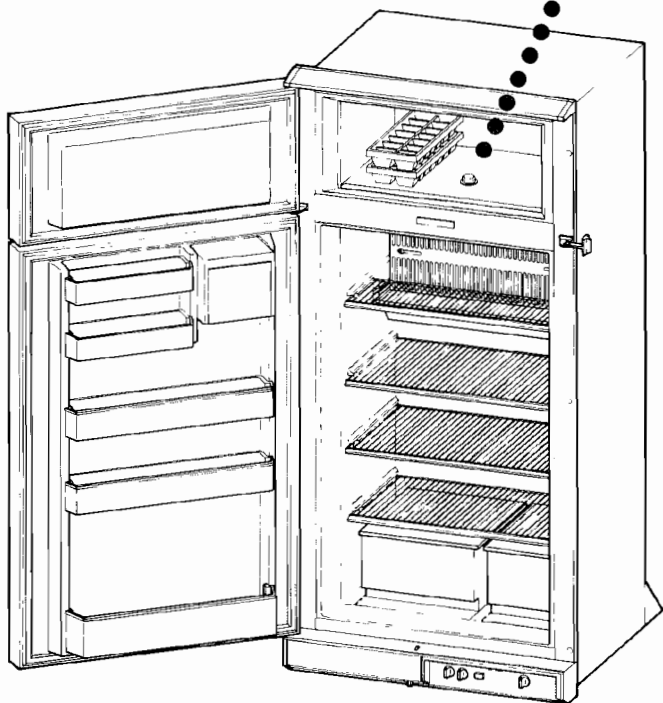
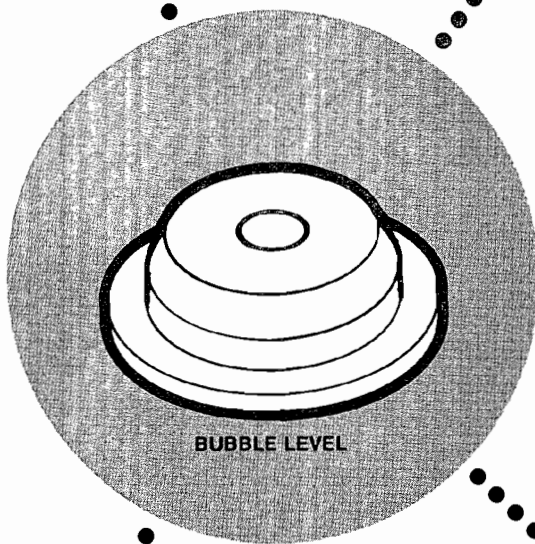
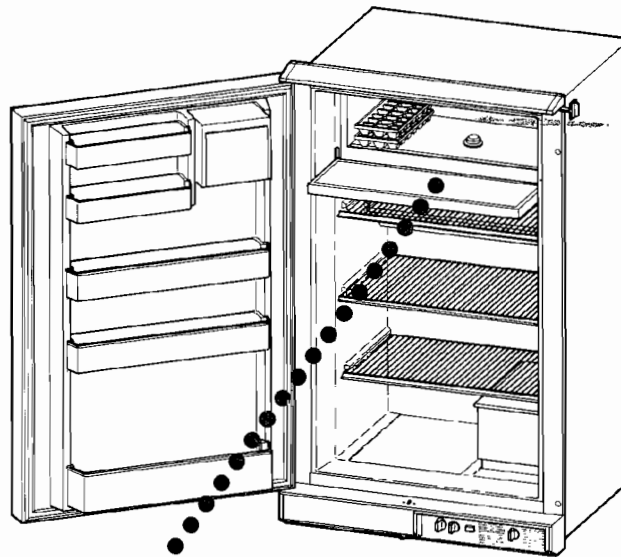
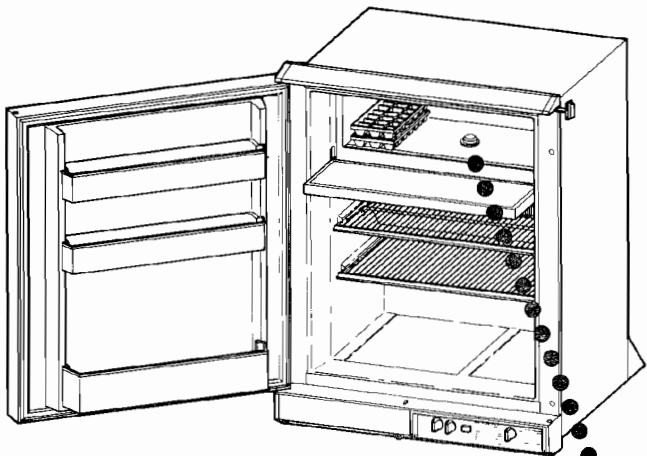

Pressure Measuring Devices

WATER "U" GAUGE

The water gauge consists of a glass "U" tube filled with water up to the mid-point. When gas pressure is exerted on one side of the gauge, the water on that side is forced down and there is a corresponding rise of water on the other side (Fig. 15).

Water column pressure is indicated by the difference of the two columns of water measured in inches.

A convenient scale reading in inches and tenths of an inch is mounted between the two columns

When reading the gauge, proceed as follows:

Fill the gauge with water up to the zero level. Connect the hose to the pressure testing outlet. Normal working pressure may force the water column to go down to 5.5 inches below the zero level, whereas the other column rises up to 5.5 inches above the point zero or midpoint. Adding the two will result in a water column of $5.5 + 5.5 = 11$ inches.

For measurement accuracy, a water "U" gauge is far superior to a low pressure gauge. If a low pressure gauge is used, it should be checked for accuracy against a water "U" gauge occasionally.

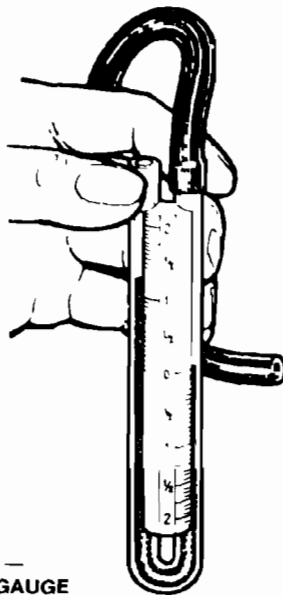

FIGURE 15 —
WATER U GAUGE

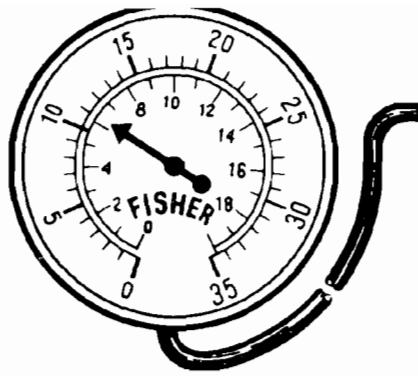

FIGURE 16 —
LOW PRESSURE GAUGE (Fisher)

(FISHER) LOW PRESSURE GAUGE

This gauge is calibrated to read in "inches of water column pressure." It is a standard manometer reading and is colored red.

HOW TO USE THE PRESSURE GAUGE

Fig. 16 shows the Fisher low pressure gauge. When testing the pressure to the burner, tee into the supply line from the gas bottle (such as a gas range pressure tap as shown in Fig. 17). Then connect the hose from the pressure gauge. It is very important that the gas operated refrigerators operate at correct pressure; i.e., at the pressure specified for the refrigerator.

The pressure of the burner should be checked at the time the refrigerator is started up. After connecting the pressure gauge, set the thermostat dial at "COLDEST." Turn on the gas and light the burner.

At the "COLDEST" setting the pressure reading should be at a minimum of $10\frac{1}{2}$ " or a maximum of $11\frac{1}{2}$ " if the L.P. gas is supplied directly to the refrigerator from the regulator fitted on the gas bottle at pressure of 11".

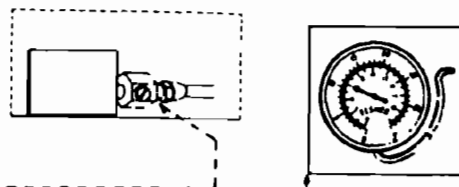
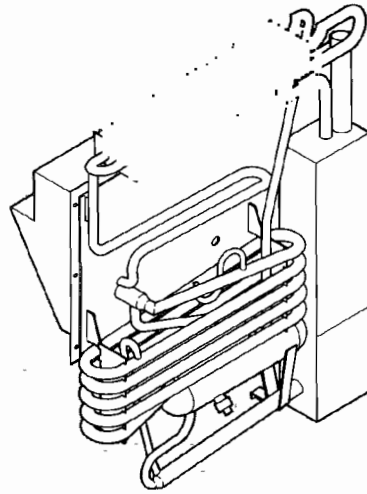

FIGURE 17 —
PRESSURE TAP
See Figure 21, page 28,
for exact location.

Types of Cooling Units

IM-40 C (TH)
Part #4-330-924



IM-60 C (TH)
Part #3-330-107

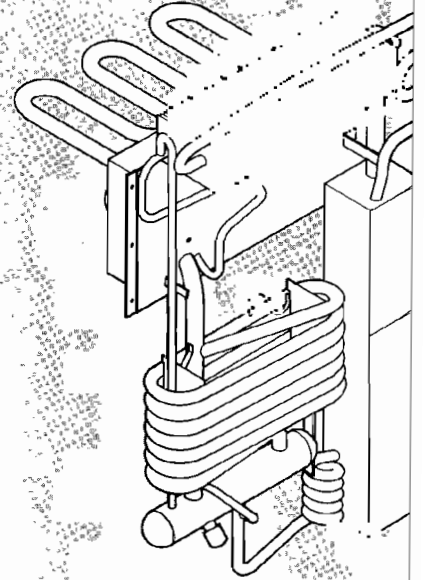

IM-60 S
Part #2-330-214

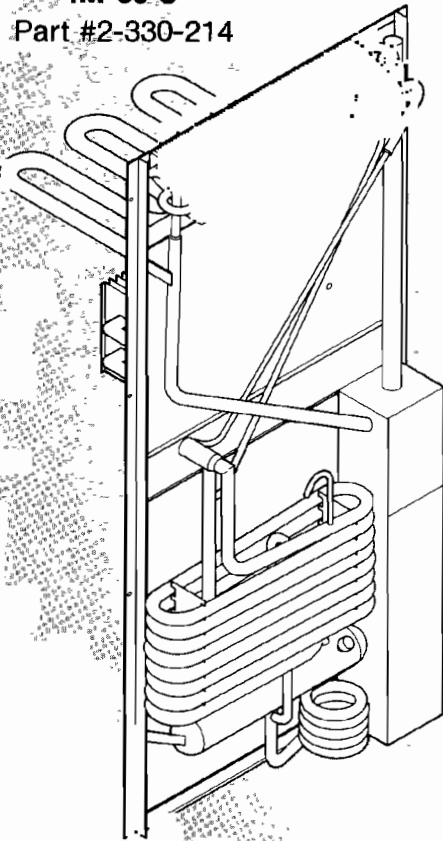

IM-70 C / IM-90 C
Part #4-330-209

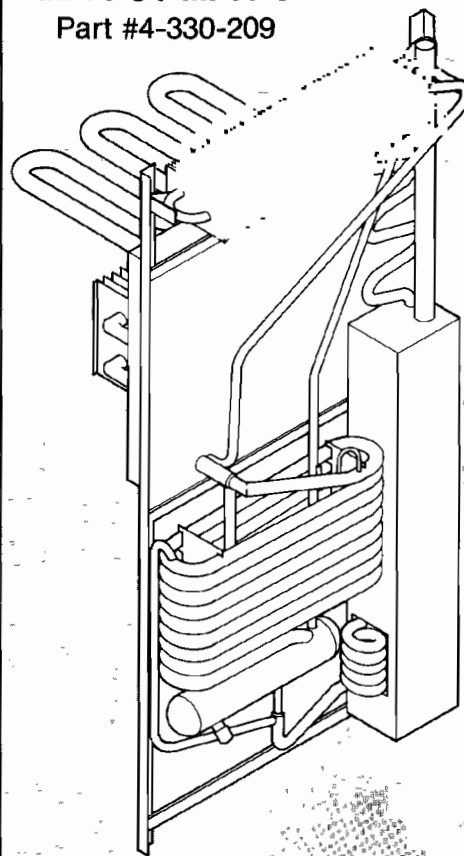

IM-90 CF
Part #3-330-901

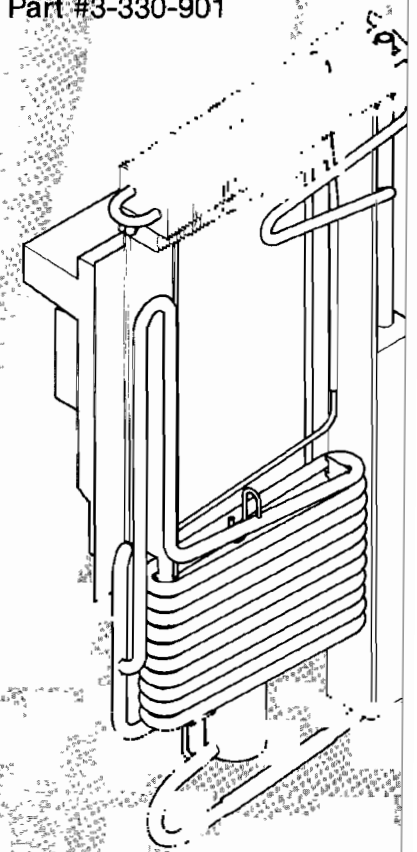

Replacing a Cooling Unit

1. With the refrigerator in the upright position, remove the mounting screws in freezer box and cut the 12V interior lamp wires behind the spade connectors.
2. Remove the protective grill from refrigerator cooling coil.
3. Loosen capillary tube from the retainer (**Fig. 19**) by backing the Phillips-head screws in the plate retainer out about two turns. Straighten the capillary tubes, being careful not to crimp or break them. Pull tubes out from back of cabinet. Carefully coil to prevent kinks or breaks.
4. Lay the refrigerator face down. Remove the two Phillips-head screws holding the burner box cover and slide the cover off (*toward the bottom of the refrigerator*). Remove both machine bolts holding the box to the bottom of the cooling unit (**Fig. 21**).
5. Pull the electrical spade connectors apart in the insulating sleeve to free the electrical heating element.
6. Remove all self-tapping metal screws holding the cooling unit to the cabinet of the refrigerator.
7. Lift the cooling unit from the refrigerator cabinet. Because of the weight and the hydraulic action of the thermal mastic, this is often a job for two people.
8. Remove the plastic inner lid (*if your unit has one*) from behind the secondary evaporator and install on the replacement unit. If liquid adhesive is available, spraying the plate lightly will provide a good seal to the new unit.
9. Perfect freezer box contact is essential. Therefore, use all of the thermal mastic supplied with the replacement cooling unit.

NOTICE:

Because a cooling unit is a delicate instrument and a major component which sometimes sustains rough handling in shipment, it is recommended that any replacement cooling unit be hung level on the wall and operated on the electric element about eight hours prior to installation on a refrigerator. Such a "run-in" assures the quality of the replacement cooling unit.

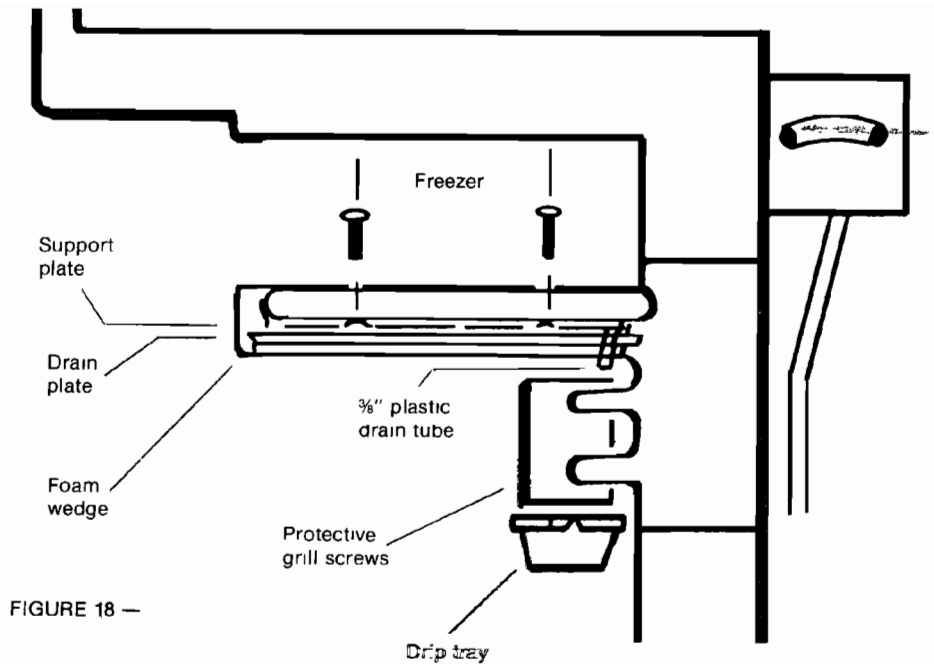
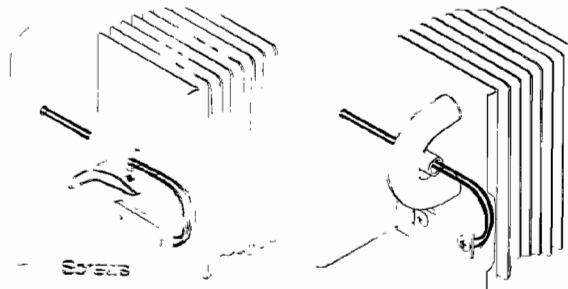

FIGURE 18 —



EVAPORATOR RETAINER

FIGURE 19 — TYPES OF CAPILLARY TUBE RETAINERS

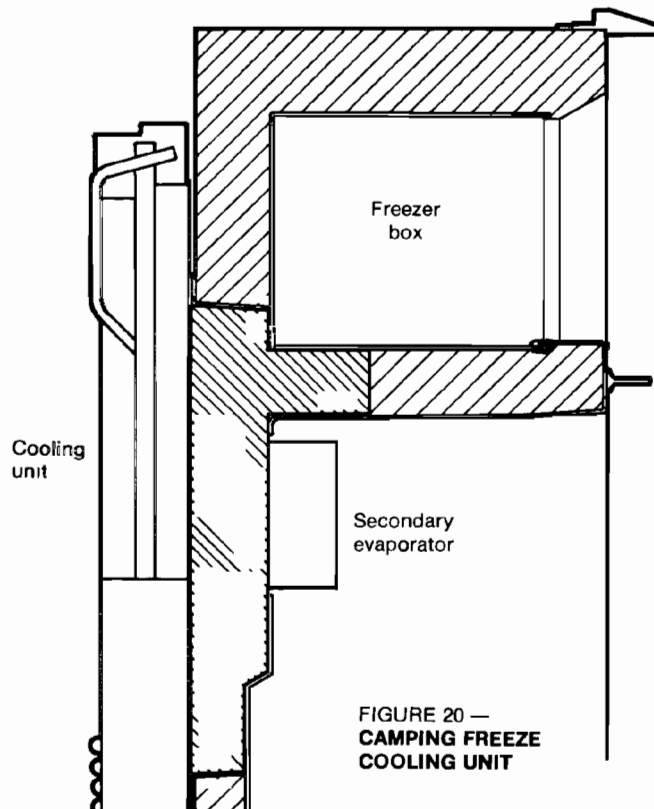

FIGURE 20 —
CAMPING FREEZE
COOLING UNIT

How to Change an Orifice

1. Hold the orifice with a 12 mm. open end wrench and disconnect the gas line flair nut with a 13 mm. wrench **Be careful!** Any sharp bends in the aluminum gas line will result in leaks and necessitate its replacement
2. Back the orifice out of the burner with a 12 mm. wrench.
3. Thread the new orifice into the burner and tighten securely
4. Carefully reposition the gas line and thread the 13 mm. flair nut onto the orifice. Make sure that the gas line is in a straight line with the burner, and, while holding the orifice in place with a wrench, tighten the flair nut firmly.

NOTE

Whenever making any repairs involving gas connections, always check for leaks when repairs are completed.

Any attempt to clean a ruby orifice with a wire-like device will crack the ruby and result in extreme malfunction!

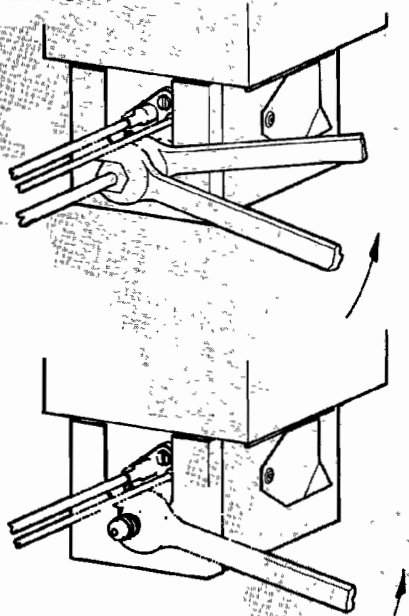

How to Change a Thermocouple

1. Removal of the burner box cover will make access to the thermocouple retaining clip easier. Remove the two Phillips-head screws which hold the cover in place and slide it back and then out.
2. Remove the igniter electrode-thermocouple retaining clip by removing the screw and pulling the igniter electrode and thermocouple out of the burner
3. Remove the blue flame meter wire from the thermocouple terminal
4. Carefully remove the 5/16" nut from the back of the gas control and remove the thermocouple.
5. Replace the new thermocouple in the burner along with the igniter electrode and replace the retaining clip
6. Thread the 5/16" nut back into the control.

Carefully torque this nut down to 20-25 inch/pounds

7. Replace the blue flame meter wire into the thermocouple interrupter (terminal) and tape if necessary
8. Replace the burner box cover (if you removed it).

How to Change a Gas Line

1. Holding the orifice with a 12 mm. wrench, loosen the 13 mm. flair nut.
2. Hold the 11 mm fitting next to the gas control (or pressure tap) and loosen the 13 mm flair nut. Be careful *not* to rotate the pressure tap.
3. Be careful to align the gas line flairs and fittings properly, and firmly tighten the two flair nuts in place. Hold the orifice with the wrench while tightening—also hold the fitting in the gas control with a wrench while tightening or removing.
4. As always, check for leaks when repairs are complete. 55-60 inch pounds torque will not damage the threads but will normally be sufficient to prevent leaks.

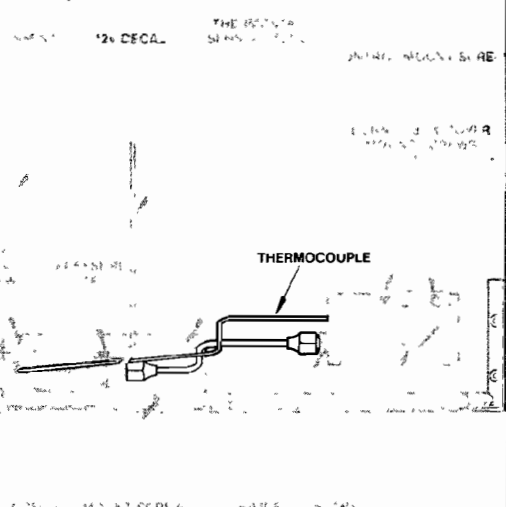

How to Change Electric Selector Switch

- 1 Remove control knob for 110V/12V selector switch.
 - 2 Remove cover of electric box by removing two Phillips-head screws from the top of the cover and sliding it off
 - 3 Remove the electric control box by removing the two Phillips screws from either side of the electric switch
 - 4 Pull control rod off of switch
 - 5 Remove all wires from selector switch
 - 6 From the front of the electric box remove the two mounting screws and remove the electric selector switch.
 - 7 Place the new electric switch in place and mount with mounting screws.
 - 8 Reconnect all wiring per proper wiring diagram
 - 9 Reposition the selector rod on the electric switch and align rod in front hole while pushing electric box back into position. Mount with the two Phillips-head screws.
- Remember to attach the 115V ground wire to the casing**
10. Attach cover with two screws.
 11. Reinstall selector rod knob.

How to Change a Sourdillon Control Assembly

Refer to pages 27 and 28 for helpful illustrations

1. Remove the *Innovator* from the built-in opening to give complete access to the unit
2. Free the thermostat sensing tube from the secondary evaporator by first removing the evaporator grille, then backing out the tube retainer screws and pulling the tube loose.
- 3 Pull the sensing tube through the back of the unit and carefully coil in 3 to 4 inch diameter loops to avoid kinking or rupturing the tube

Sensing tube is not a field replacement item.

If the tube is damaged by mishandling, other parts (*thermocouple igniter, gas inlet, pressure tap, etc.*) may be salvaged and the control scrapped

- 4 Remove control knobs.
- 5 Remove the two 1/2" sheet metal burner box cover screws and slide off the burner box cover
6. Remove the two 1/2" machine bolts (*slotted or hex*) to free the burner box from the flue tube assembly.
- 7 Pull the two white thermostat wires on the control (*spade connectors*) and the blue wire from the flame meter to the thermocouple interrupter. Also disconnect the igniter wire from the igniter electrode.
8. Loosen the control mounting bracket by removing the 3 or 4 sheet metal screws holding it in place.
9. Carefully pull the bracket and control straight back.

NOTE: The microswitch terminals on the inside rear of the bracket may catch on the sheet metal base slot a sudden pull will break the microswitch and necessitate replacement.
Be careful!

10. Back the control out of the unit. Both the thermostat and gas/electric switch control rods, springs and retainers may remain on the control. If they do not, retrieve them with a coat hanger wire
- 11 Exchange the control mounting bracket. Four Phillips-head screws hold the bracket to the control. When replacing on the new control, be careful not to strip the threads in the aluminum valve body
- 12 Exchange the burner bracket. Two sheet metal screws hold the burner to the bracket. Firmly tighten screws to new burner for proper flame alignment.
- 13 Push control rods, springs and retainers about 75% of the way into the rod slots. Allow enough room to replace them on the control assembly as you push it back into place. This becomes easier with a second person helping at the front of the unit.
14. Replace the three or four sheet metal screws which hold the control mounting bracket in place. **One of these screws must hold the green ground wire from the flame meter.**
15. Replace blue wire from the flame meter to the thermocouple interrupter spade connector and two white thermostat wires. Also replace igniter wire to igniter electrode.
16. Remount burner bracket to flue tube assembly and replace burner box cover.
17. Replace control knobs.
18. Carefully uncoil sensing tube. Push through back of cabinet and reinstall on secondary evaporator.
- 19 Replace *Innovator* into built-in opening.

How to Change a Lamp Switch

Refer to illustrations on page 27 for component locations

- 1 Follow Steps 1 through 10 on removal of Sourdillon Control Assembly, page 25. *Omit Steps 2 and 3 but be careful not to damage the sensing tube as noted in Step 3.* It is only necessary to pull the control far enough out to clear the control rods from the front panel

On 3-way units it is necessary to remove the electric control rods also. Remove the control rod knob first. Then remove the two Phillips-head screws from the electric box cover and remove cover. Only the two Phillips-head screws inside the electric box need to be removed to remove the electric box assembly (*If a separate screw is used for connecting the 110V ground it needs to be removed also*). Pull the box far enough out to remove the control rod

2. Remove main door.
- 3 Remove hinge pin from control box as well as plastic cap in opposite hinge pin hole
4. Remove plastic end caps from control box

NOTE: On some *Innovators*, a screw was placed up from the bottom of the control box to secure the end cap. This must be removed to remove the end caps.

5. Remove control box cover by sliding it out to one side
6. Remove operating instructions decal by peeling off from one corner.
7. Pull the flame meter out and disconnect the blue and green wires from the terminals.
- 8 Slide the control box panel from the control box.

- 9 Disconnect the two black wires from the light switch terminals.
- 10 Carefully drill the pop rivets out from the top of the control box and free the light switch from the mounting holes
- 11 Place the new light switch in position and pop rivet in place. Be sure to use washers on the bottom side of the switch to be sure it is held securely.
- 12 Reconnect the black wires to the light switch terminals
13. Slide the control box panel back in place. **Note that this part must go in first slot** closest to the unit so that the sliding cover may go in the second slot
- 14 Reconnect the flame meter, being careful to get the correct polarity (*green — positive and blue — negative*).
15. Reposition the flame meter in the slot on the control panel and carefully position the decal in the proper place

- 16 Replace the sliding cover and end caps. Also replace the hinge pin and plug.
- 17 Follow Steps 13 through 17 "How to Change a Sourdillon Burner"

On 3-way units, it is necessary to replace the electric box and control rod. Start by replacing the control rod assembly into the hole provided. Connect the switch to the control rod and slide this assembly up to the cabinet back. **Note that the control rod must be aligned properly in front of the unit.** Replace the two Phillips-head screws into the electric box and secure it to the cabinet back.

NOTE

Don't forget to reconnect the 115V ground wire to the metal casing. Replace the electric box cover and control rod knob.

- 18 Replace main door.
19. Replace *Innovator* into built-in opening.

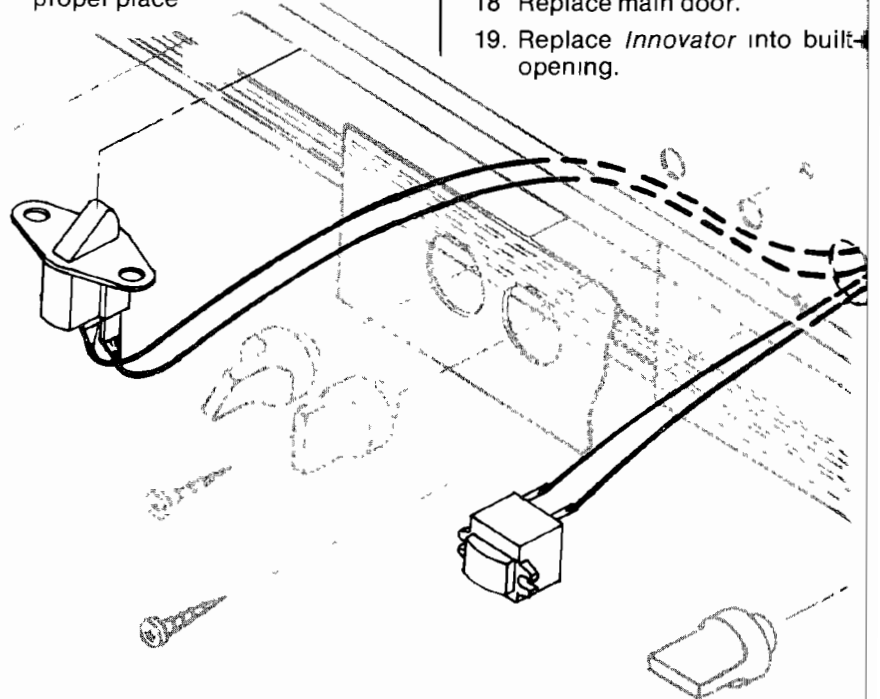

- 3. Decal
- 4. Thermostat Control Knob
- 5. Gas/Electric Selector Knob
- 6. Flame Meter
- 7. Electrical (12V-115V) Control Knob
- 8. Control Cover
- 9. Base Spacer Block, Bottom
- 10. Base Spacer Block, Top
- 11. Cabinet
- 12. Electrical Control Rod Assembly
- 13. Electrical Box Assembly
- 14. Electrical Box Cover
- 15. 115V Power Supply Cord
- 16. Fuse Holder/Fuse
- 17. Auto Ignition
- 18. Burner Bracket
- 19. Burner Control Assembly
- 20. Gas/Electric Selector Control Rod Assembly
- 21. Thermostat Control Rod Assembly
- 22. Foam Tape

- 23. Cabinet Molding, Bottom
- 24. Cabinet Side Molding, L. H.
- 25. Lamp Assembly

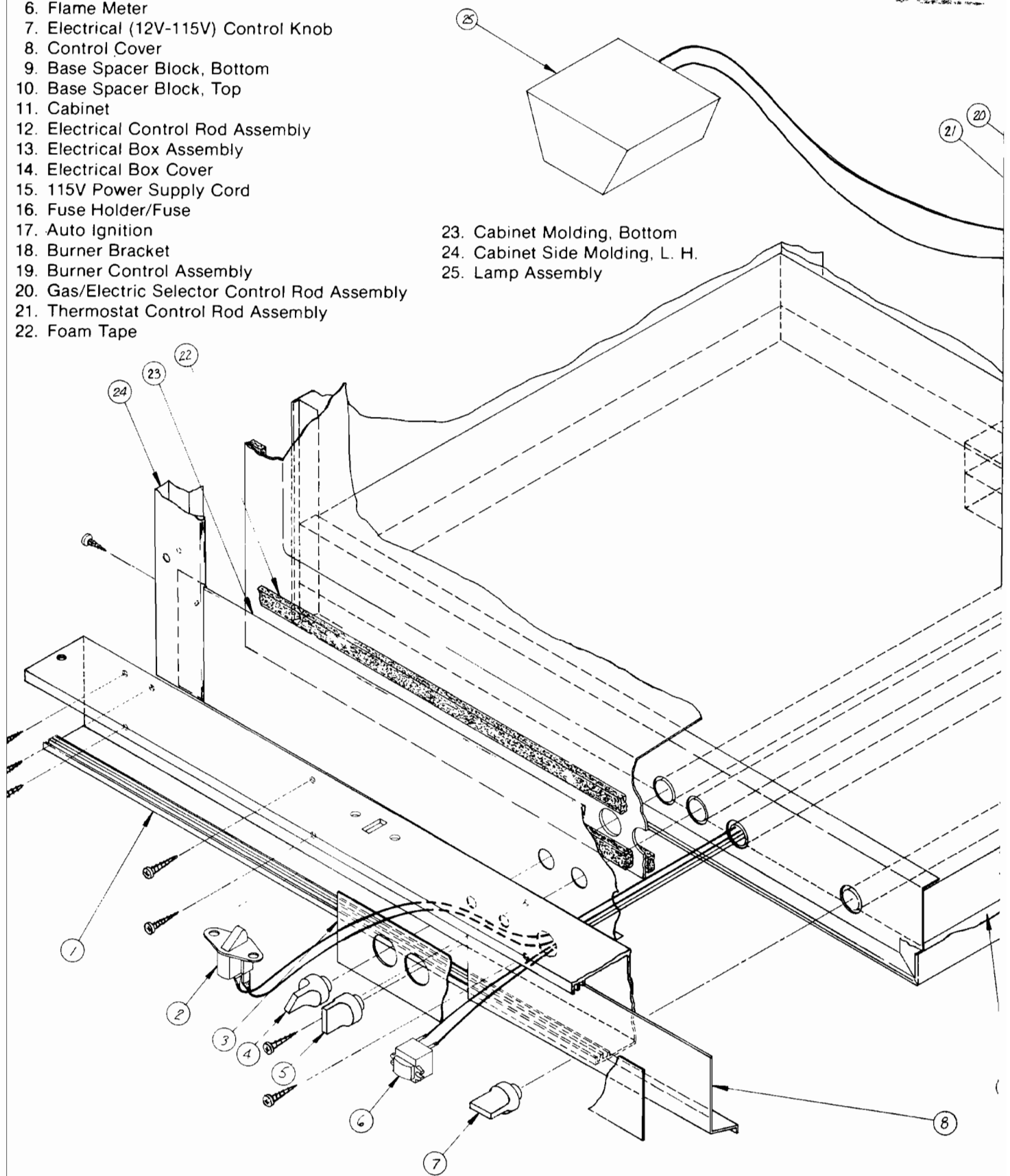

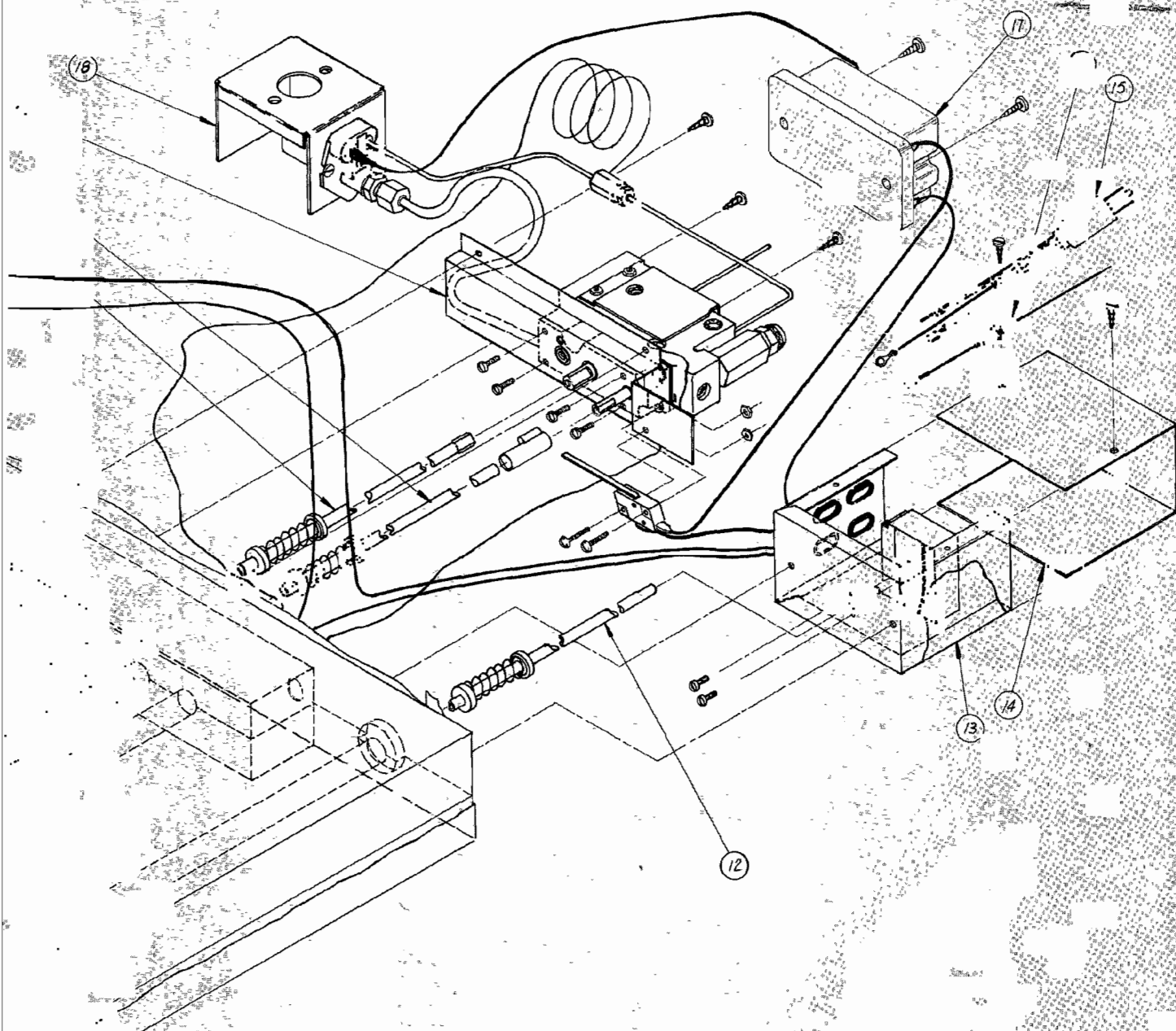

**CONTROL
SCHEMATIC and
PARTS LIST for
ALL INNOVATORS**

**IGNITION
TRANSFORMER**

12V TERMINAL

**ELECTRICAL
UNCTION BOX**

**CONTROL
MOUNT
SCREW**

PI

GAS INLET

CONTRC

FIGURE 1

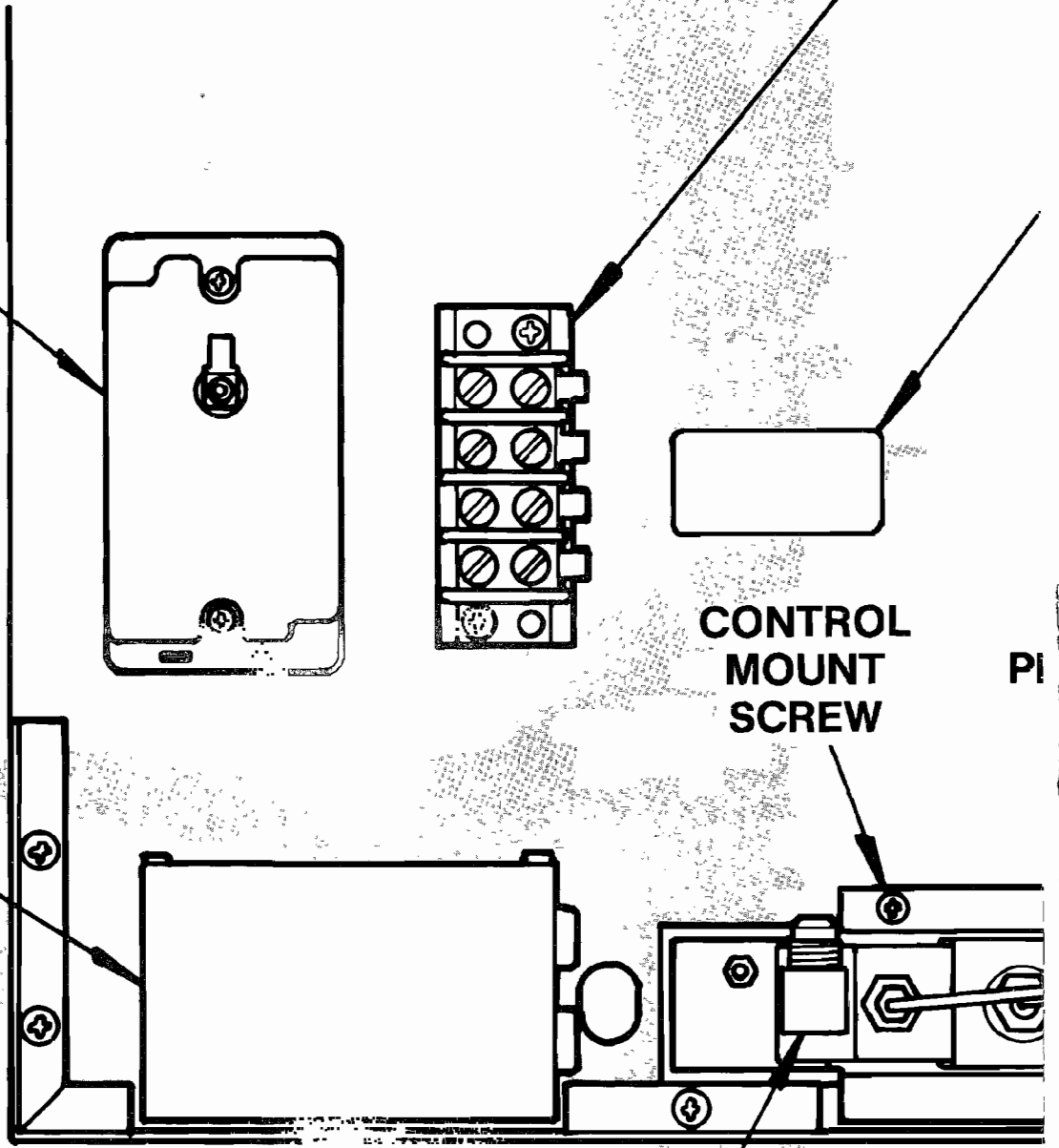

Changing Lamp Cartridge

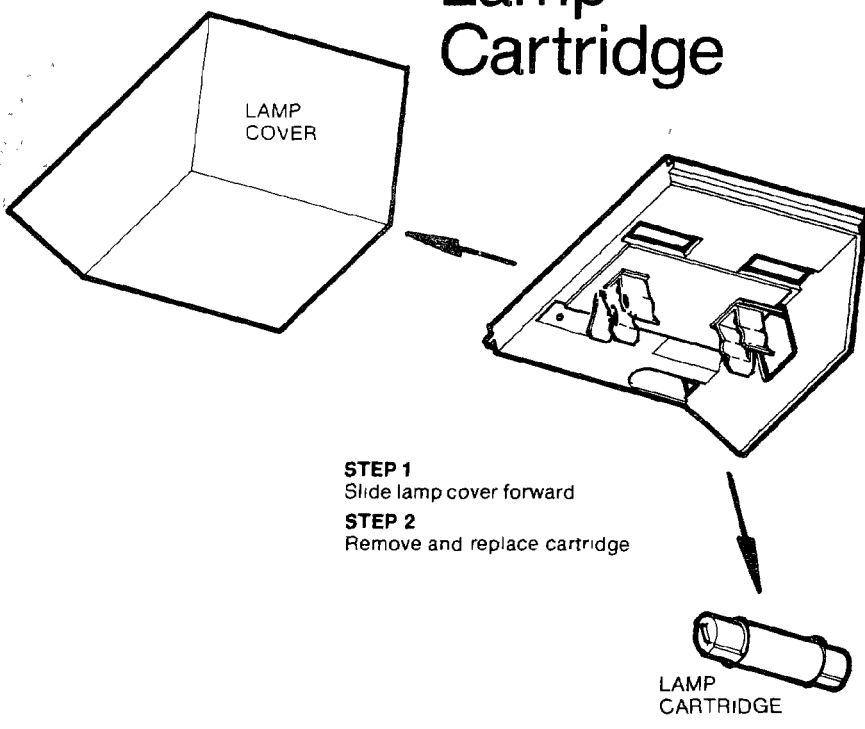
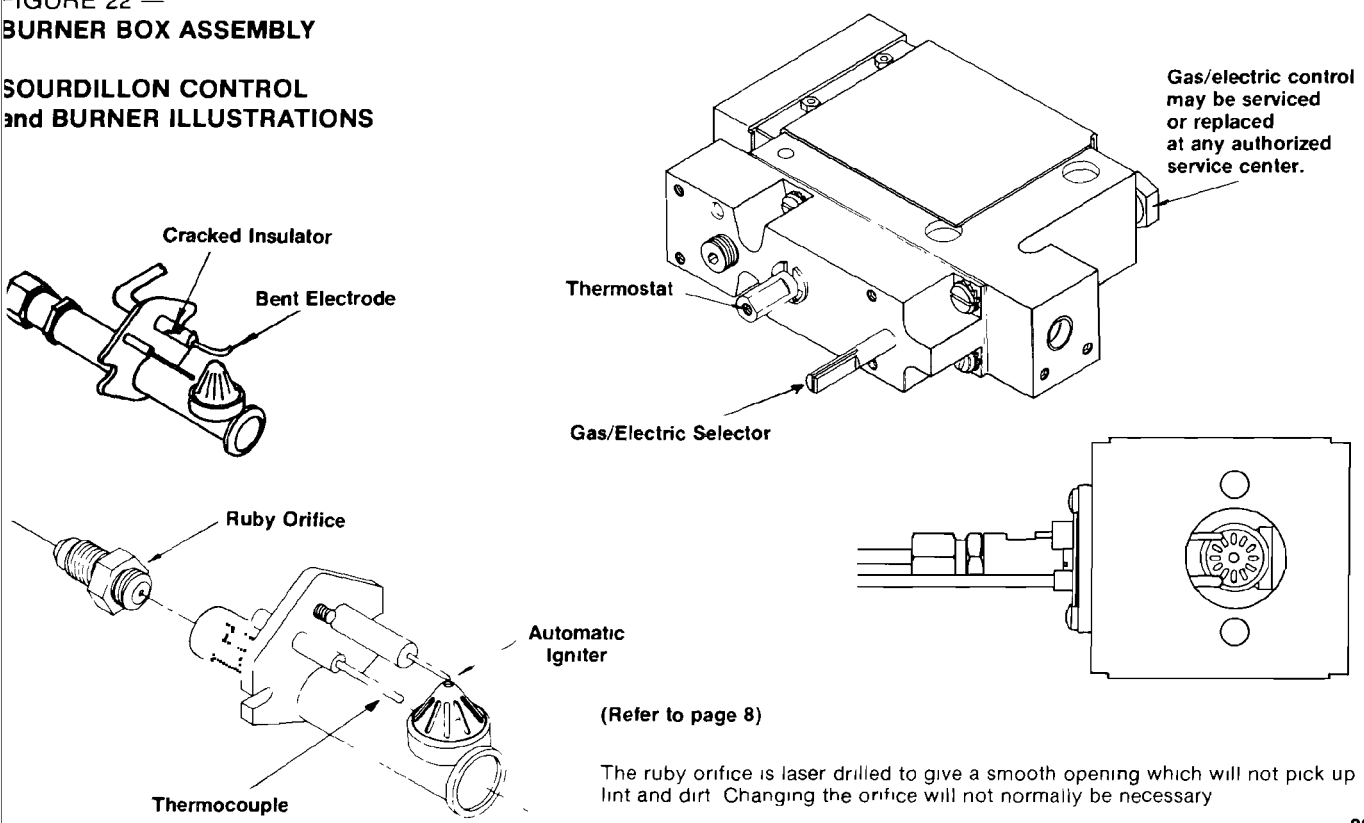

FIGURE 22 —
BURNER BOX ASSEMBLY

SOURDILLON CONTROL and BURNER ILLUSTRATIONS



Can the Innovator Operate Without a 12 Volt Power Supply?

The answer is **YES!**

Simply slide open the burner observation port and apply a lighted match or your Instamatic Magiclick 2000 to the burner.

Your helper can depress the Gas/Electric selector and make sure gas is flowing to the burner. As soon as the flame meter moves to the right, he (*your helper*) can release the selector and the magnetic safety will take over.

The only inconvenience you will experience is, of course, the lack of interior lighting without the 12 volt power supply. Otherwise the *Innovator* should operate normally.

Call out #	Part #	Description	IM 40	IM 60	IM 70
1	3-320802	Door Trim Assembly		•	•
2	3-320713	Freezer Door Complete	•	•	
2	3-20823-001	Freezer Door Complete			•
2	3-320887	Freezer Door Complete			•
3	5-330829	Body Liner	•		
3	5-330708	Body Liner		•	
3	5-330816	Body Liner			•
4	3-320773	Butter Box Assembly	•	•	•
5	3-330776	Egg Tray		•	•
6	3-330720	Bottom Body Shelf	•	•	•
7	3-330719	Center Body Shelf			•
9	3-330718	Top Body Shelf	•	•	
9	3-330817	Top Body Shelf			•
10	3-330786	Drip Tray	•	•	•
11	3-330897	Evaporator Grille	•	•	
11	3-330892	Evaporator Grille			•
12	2-330766	Travel Lock	•	•	•
14	2-330805	Lamp Cover	•	•	•
15	3-320794	Lamp Base Assembly	•	•	•
16	2-330821	Center Hinge			•
17	1-330230	Hinge Pin Center, Bottom	•	•	•
18	1-330553	G/E Name Plate			•
19	2-330818	Cabinet Molding—Center			•
20	3-330832	Cabinet Molding—L. H.	•		
20	4-330723	Cabinet Molding—L. H.			•
20	4-330819	Cabinet Molding—L. H.			•
20	3-330877	Cabinet Molding—L. H.			•
21	3-330721	Cabinet Molding—Top	•	•	•
22	3-330780	End Cap—Top, L. H.	•	•	•
23	1-330779	Hinge Pin, Top	•	•	•
24	4-330725	Top Cap Extrusion	•	•	•
26	3-330781	End Cap—Top, R. H.	•	•	•
29	2-330749	Auto Ignition Assembly	•	•	•
30	3-340731	Electrical Box Cover	•	•	•
31	2-330734	Terminal Block 110V—2-prong			•
31	1-030084	Terminal Block 110V—4 Prong			•
32	4-330743-001	Sourdillon Gas Control Assy (red stripe)	•		
32	4-330743-002	Sourdillon Gas Control Assy (blue stripe)		•	•
32	4-330743-002	Sourdillon Gas Control Assy (green stripe)			•
33	3-320747	Electrical Box Assembly (110V)	•	•	•
33	3-320728	Electrical Box Assembly (12V)	•	•	•
34	3-320736	Burner Bracket Cover Assembly	•	•	•
35	3-320754	Selector Rod Assembly T/W (blue)	•	•	•
36	3-320758	G/E Control Rod Assembly (red)	•	•	•
37	3-320750	Thermostat Control Rod Assy (yellow)	•	•	•
38	4-340845	Rear Support Plate	•	•	•

Call-out #	Part #	Description	IM-40	IM-60	IM-70	IM-90
41	3-330831	Cabinet Molding—R. H.	•			
41	3-330724	Cabinet Molding—R. H.		•		
41	4-330820	Cabinet Molding—R. H.			•	
41	3-330878	Cabinet Molding—R. H.				•
42	3-330722	Cabinet Molding—Bottom	•	•	•	•
43	4-330727	Control Panel	•	•	•	•
44	2-330762	Slide Plate, Control Panel	•	•	•	•
45	3-330763	End Cap, Bottom—R. H.	•	•	•	•
46	2-330761	Knob	•	•	•	•
47	4-330726	Control Box Assembly, Extrusion	•	•	•	•
48	3-330764	End Cap—Bottom, L. H.	•	•	•	•
50	3-330785-002	Vegetable Tray w/Cover, Small				
51	3-330784-001	Vegetable Tray w/Cover, Large				
53	3-330777	Door Shelf, Small	•	•	•	•
54	3-330778	Door Shelf, Bottom	•	•	•	•
55	3-320802	Decoration Trim—Name	•	•	•	•
55	3-320799	Decoration Trim—Lower			•	•
56	3-320853	Main Door, Complete	•			
56	3-320767	Main Door, Complete		•	•	•
59	2-330757	Flame Indicator	•	•	•	•
62	3-330803	Wiring Diagram Decal (110V)	•	•	•	•
62	3-330702	Wiring Diagram Decal (12V)	•	•	•	•
64	1-330138	Warning Label	•	•	•	•
*	2-320791	Freezer Hinge Assembly, L. H.	•	•		
*	2-320790	Freezer Hinge Assembly, R. H.	•	•		
*	3-330804	Lamp Bulb	•	•	•	•
*	3-330796	Lamp Switch	•	•	•	•
*	2-330740	Plastic Shelf Edge Retainer	•	•	•	•
*	1-330741	Wire Shelf Edge Collapsible	•	•	•	•
*	1-030063-003	Cap Plug	•	•	•	•
*	1-330337	Ice Cube Bucket			•	•
*	2-330363	Plastic Ice Tray (Petite)	•	•		
*	2-330679	Plastic Ice Tray			•	•
*	3-330765	Hole Plug	•	•	•	•
*	4-330772-001	Door Gasket	•			
*	4-330772-002	Door Gasket		•	•	•
*	4-330772-003	Freezer Door Gasket			•	
*	4-330772-004	Freezer Door Gasket				•
*	3-330787	Butter Tray		•	•	•
*	1-330702	Plastic Door Cap	•	•	•	•
*	3-330842	In-Line Fuse Holder			•	•
*	3-340733	Burner Bracket	•	•	•	•
*	2-330745	Ignition Switch	•	•	•	•
*	2-330749-002	Ignition Wire	•	•	•	•
*	2-330730	T/W Switch Less Wires	•	•	•	•
*	2-330848	Control Decal (110V)			•	•
*	2-330793	Control Decal (12V)			•	•

FIGURE 23

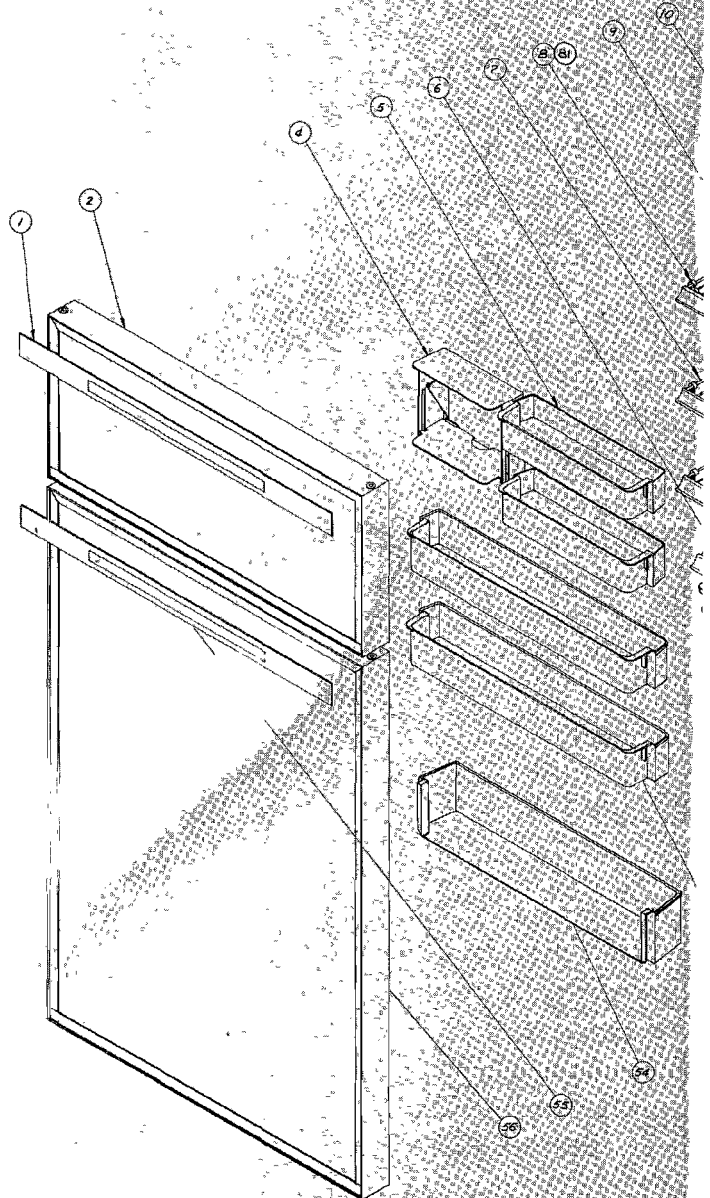

*Not shown in illustration. See following illustration—Figure 24 page 32

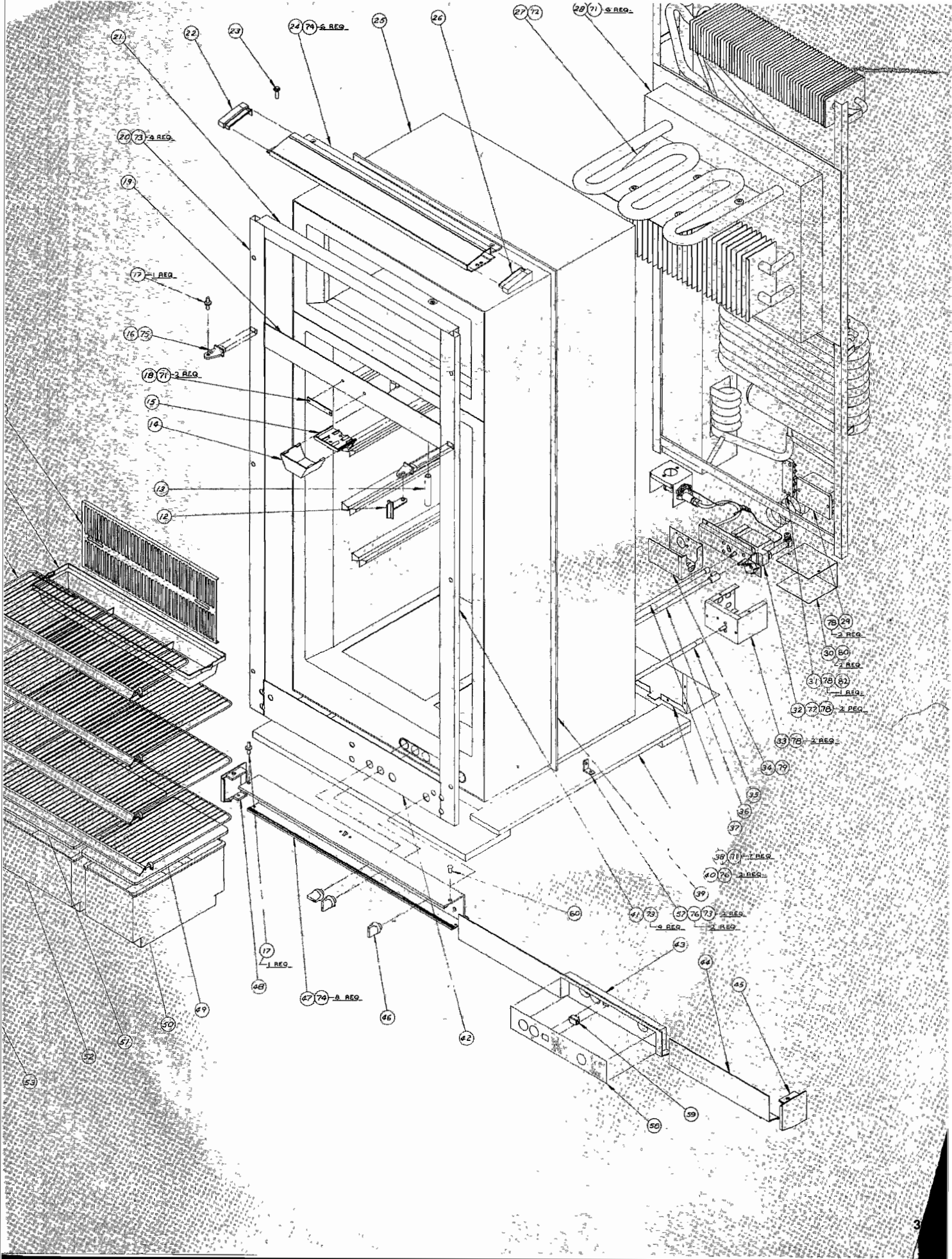

- 29 1-330796 Interior Lamp Switch
- 30 3-340731 Electrical Box Cover
- 31 2-330730 110V-12V Selector Switch
- 32 2-330745 Igniter Switch
- 33 3-320747 Electrical Box Assembly
- 34 3-320736 Burner Bracket Cover
- 35 3-320754 110V-12V Selector Rod Assembly (Blue)
- 36 3-320758 Gas/Electric Control Rod Assembly (Red)
- 37 3-320750 Thermostat Control Rod Assembly (Yellow)
- 38 3-340733 Burner Bracket
- 39 3-340744 Control Mounting Bracket
- 40 2-330760 Rod Cam
- 46 2-330761 Control Knob
- 47 39580 Thermocouple
- 48 2-030016 Heyco SR30-1 Strain Relief
- 59 2-330757 Flame Indicator

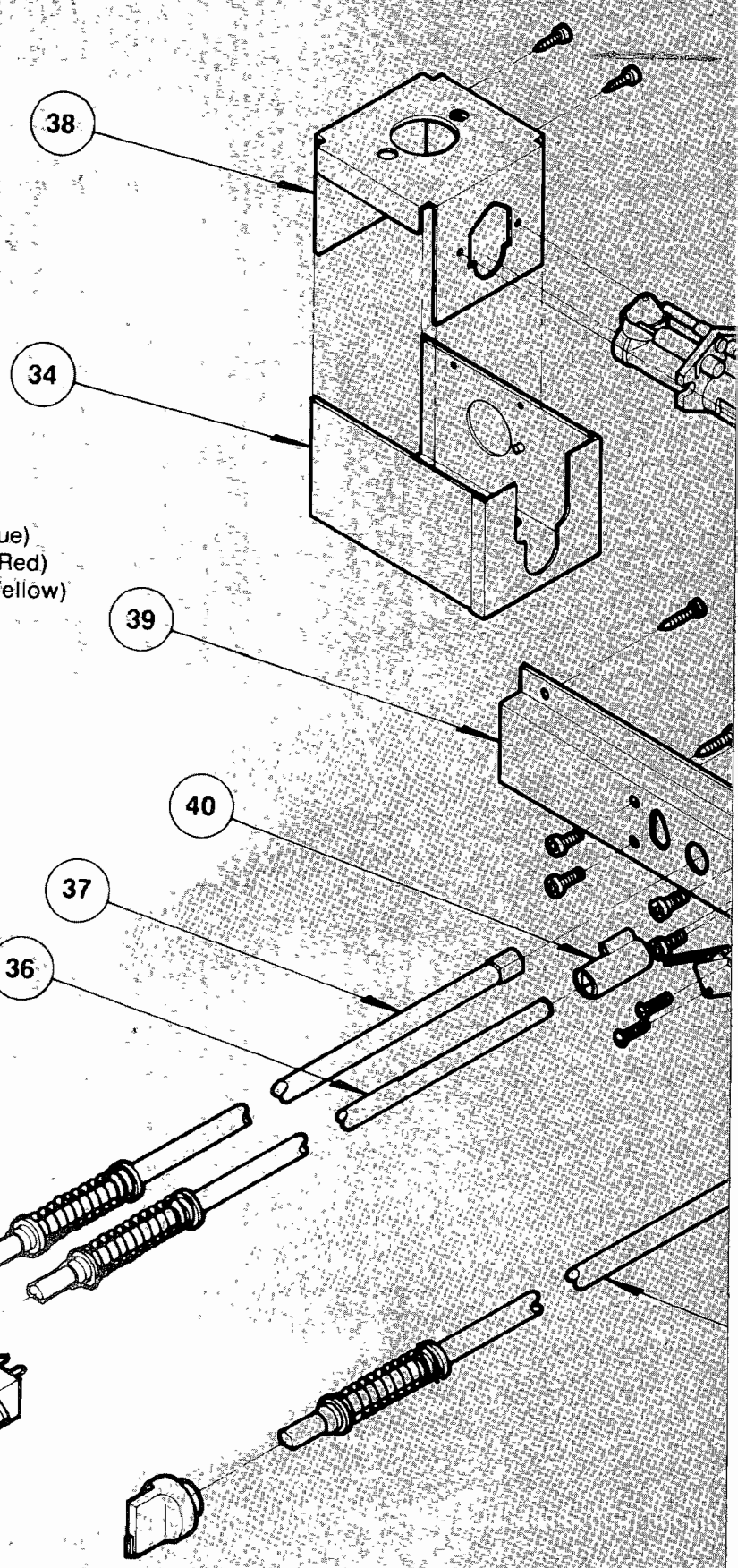

Schematic of entire control assembly from front panel knobs to . . . final assembly!

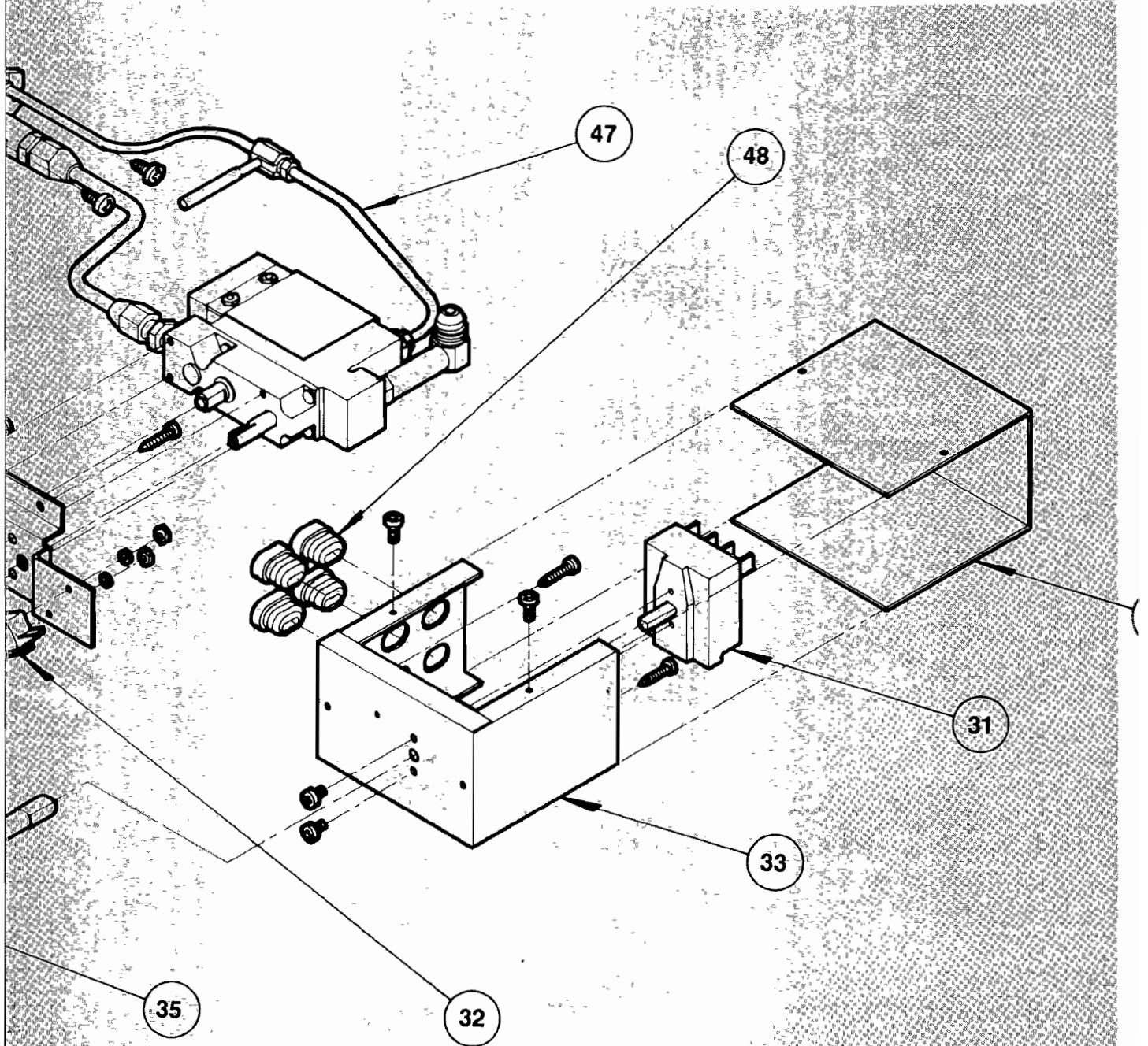
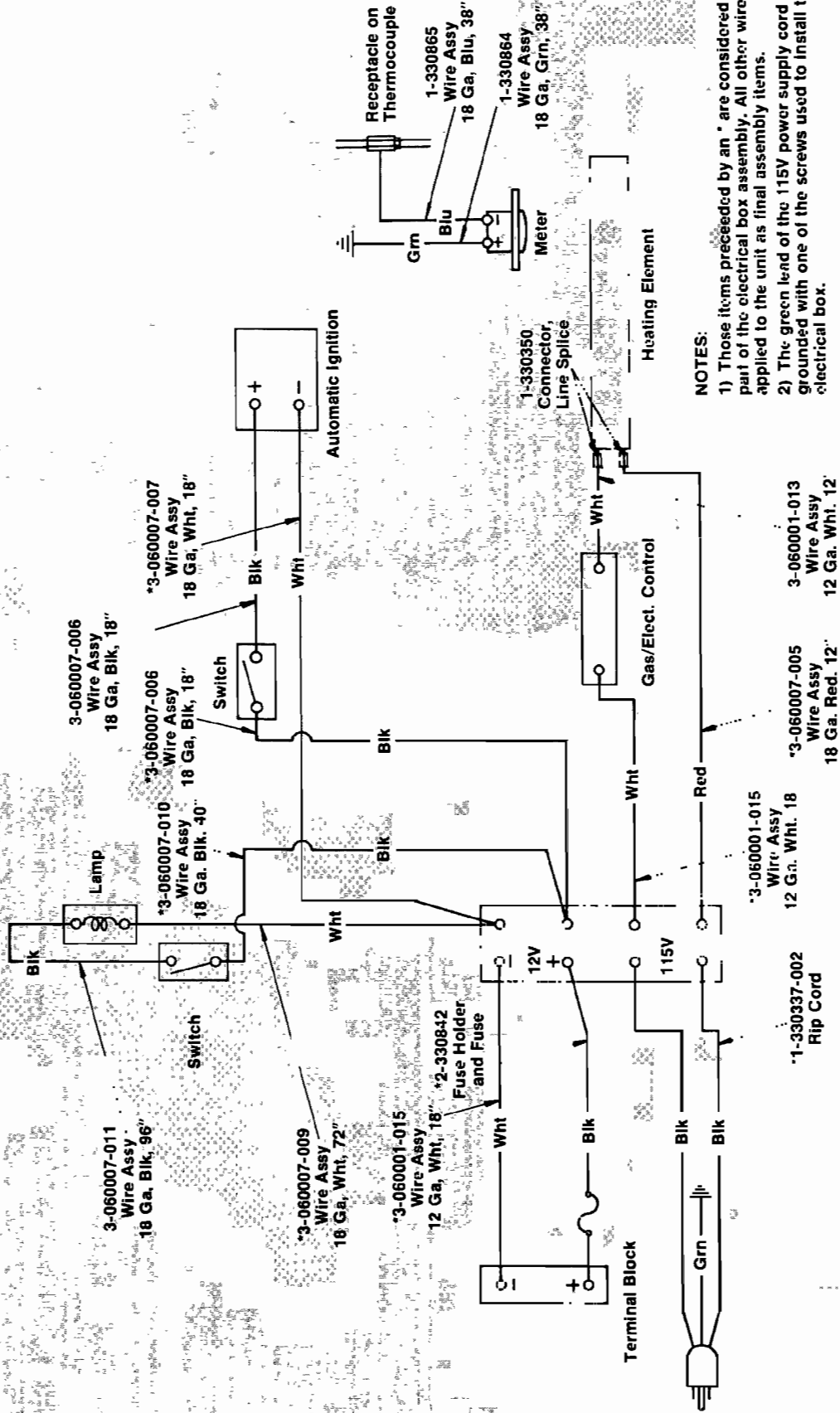

FIGURE 24

PARTS COMMON TO ALL INNOVATORS

**FIGURE 25 —
2-WAY WIRING DIAGRAM**



NOTES:
 1) Those items preceded by an * are considered to be a part of the electrical box assembly. All other wires are applied to the unit as final assembly items.
 2) The green lead of the 115V power supply cord is to be grounded with one of the screws used to install the electrical box.

FIGURE 26 —
3-WAY WIRING DIAGRAM
(single element)

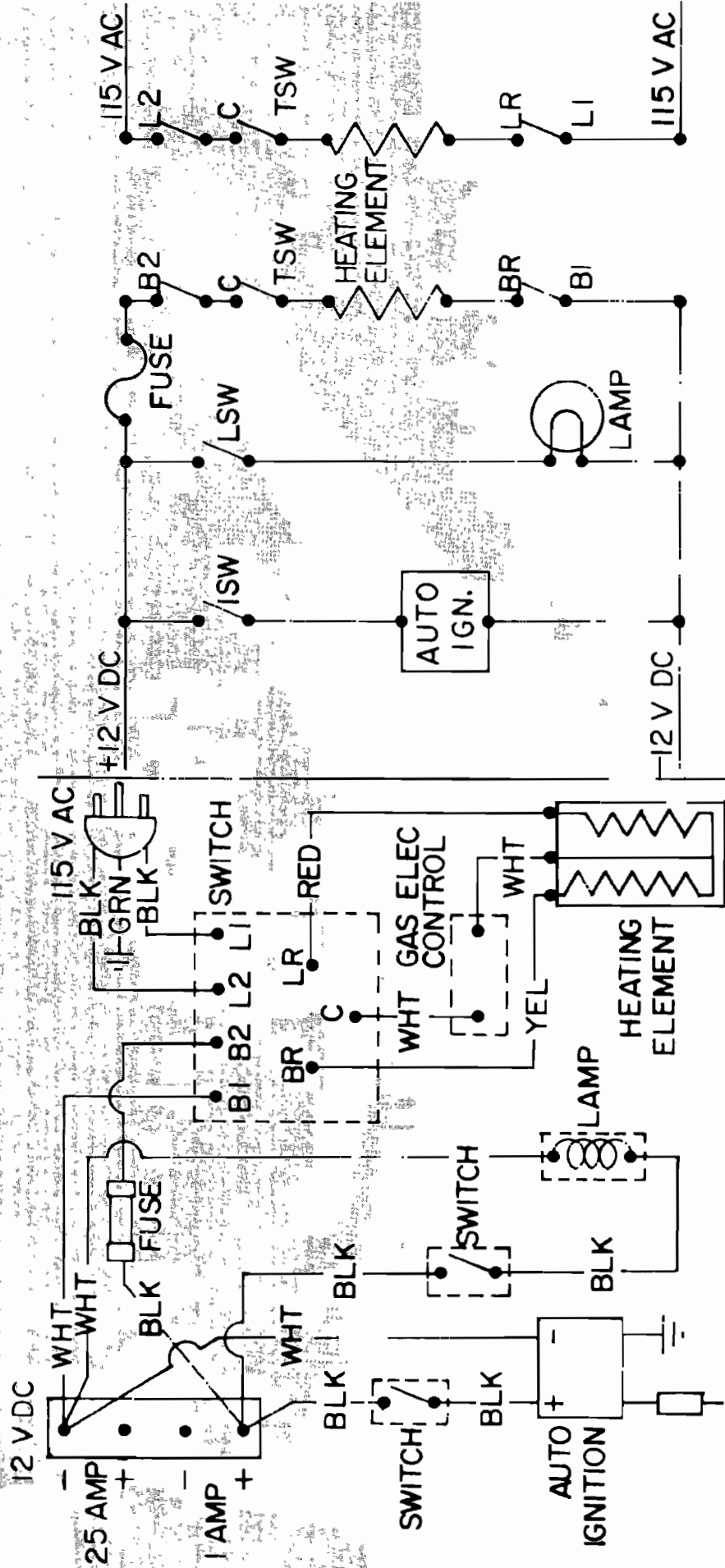
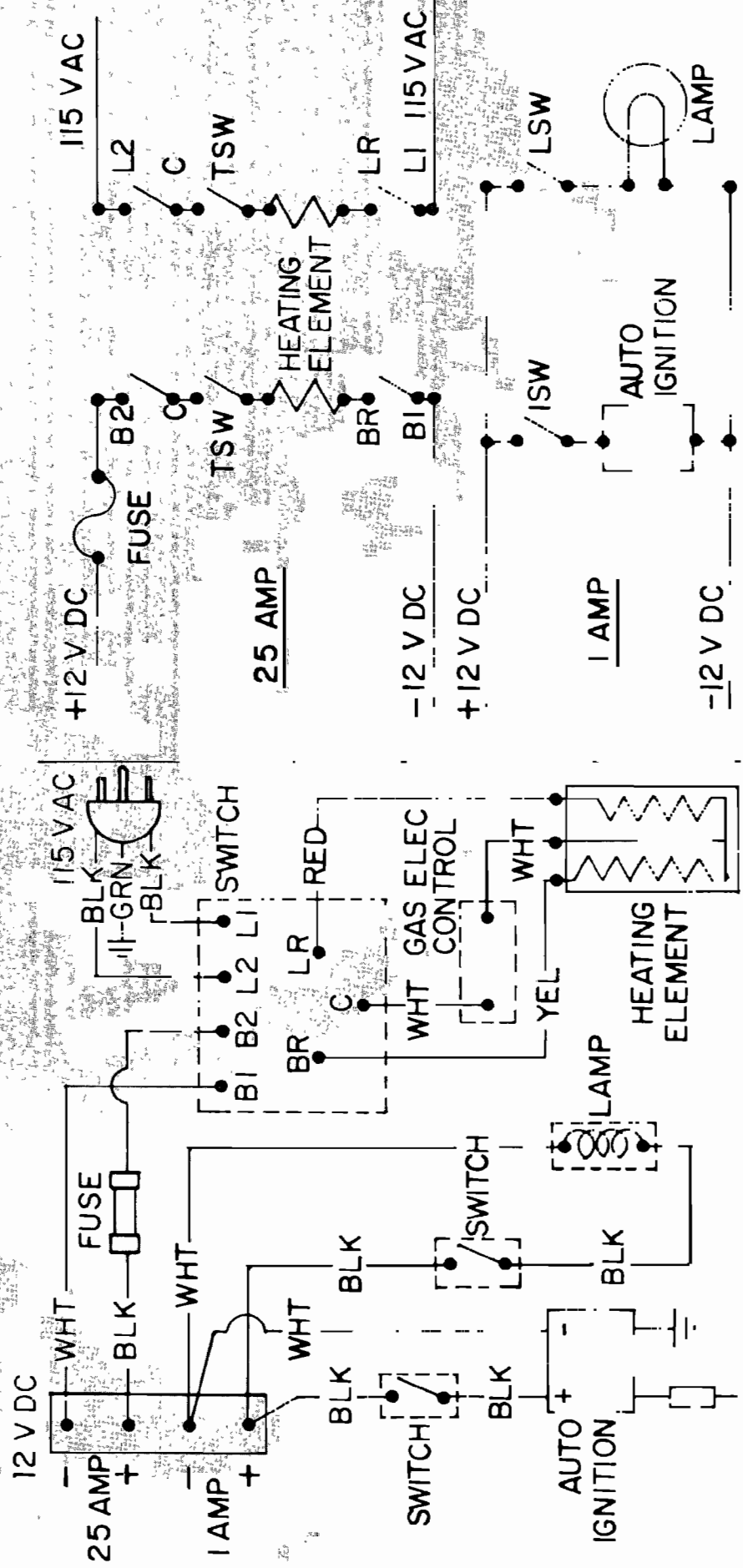

FIGURE 27 —
 ALTERNATE 3-WAY WIRING DIAGRAM
 (single element)
 for separate heating element and igniter/lamp circuits



**FIGURE 28 —
3-WAY WIRING DIAGRAM
(double element)**

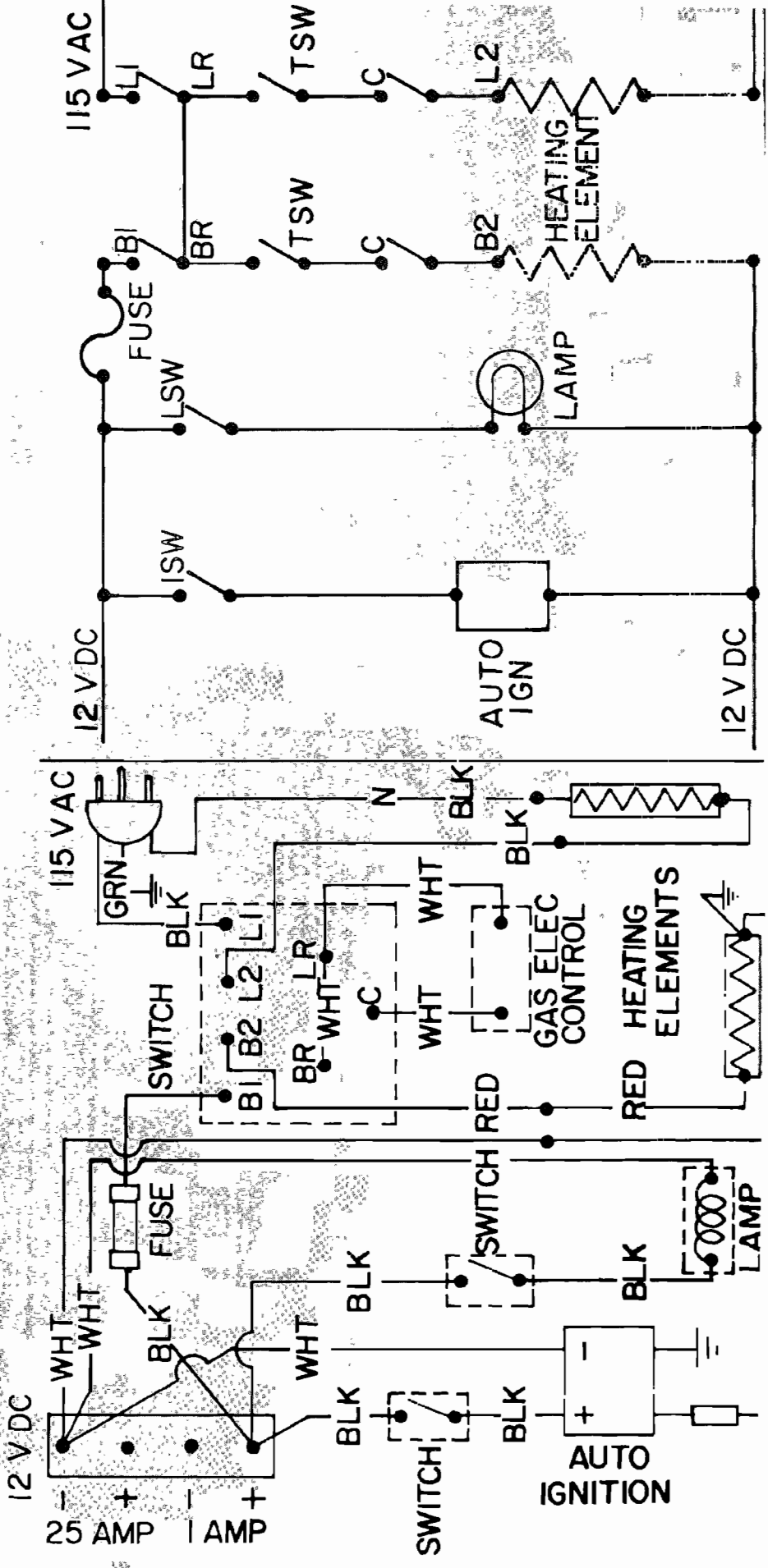
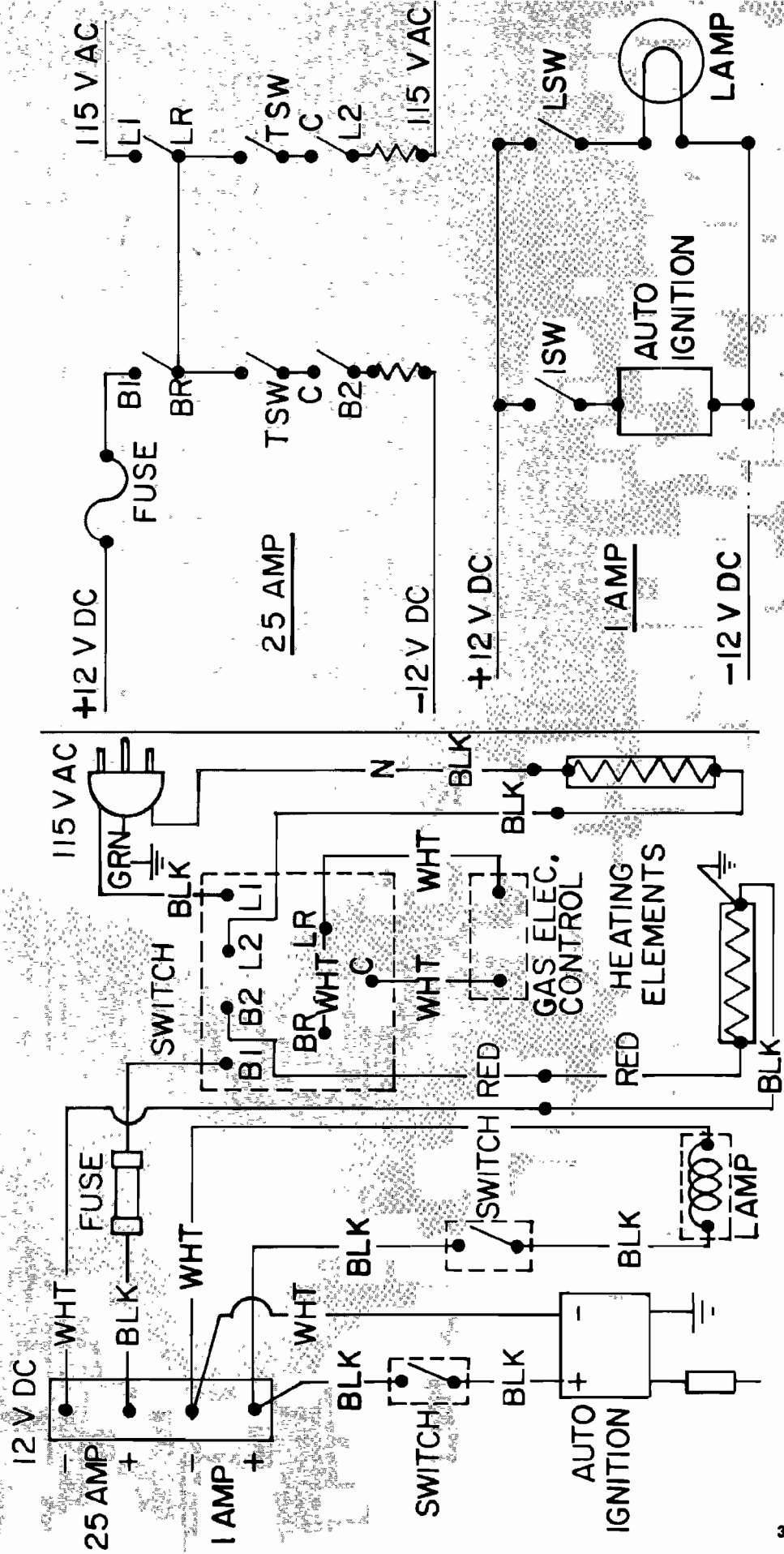

FIGURE 29 —
 ALTERNATE 3-WAY WIRING DIAGRAM
 (double element)
 for separate heating element and igniter/lamp circuits



Replacing Heating Element in Gas/Electric Refrigerators

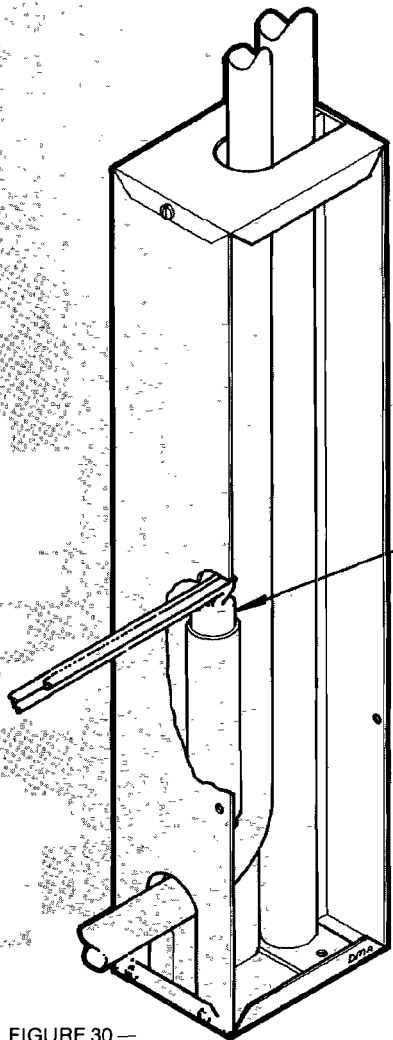

FIGURE 30 —
SINGLE ELEMENT
CONSUL BOILER BOX
IM-40 C

On the gas/electric operated refrigerators, heat is supplied by an electric element (A) mounted on the cooling unit inside the insulated cover (B)—removed for illustration purposes. See Fig. 30, 31, and 32.

The element is accessible for replacement after removal of insulated cover and the rockwool insulation.

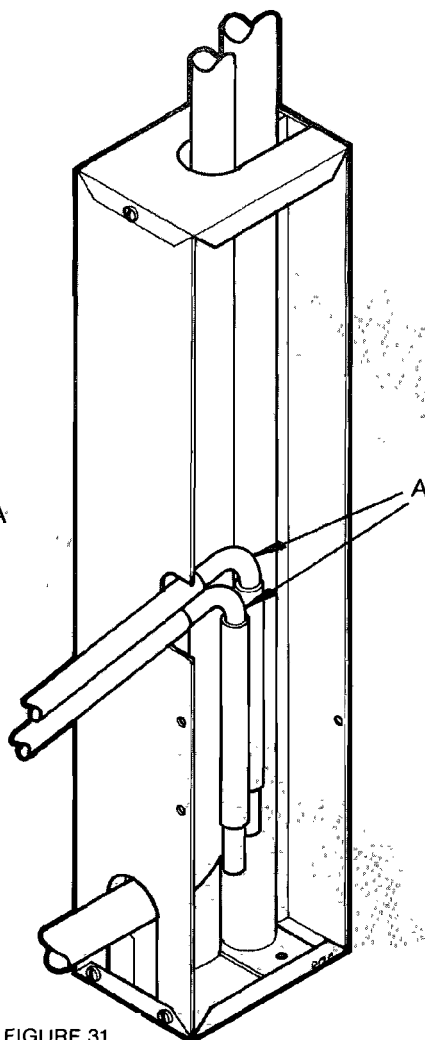

FIGURE 31
DOUBLE ELEMENT
CONSUL BOILER BOX
IM-40 C

1. Check that the size and wattage of the heater are correct for the unit. Heater should fit snugly to provide proper heat transfer.
2. Check that the supply voltage corresponds to the voltage stamped on the heating element

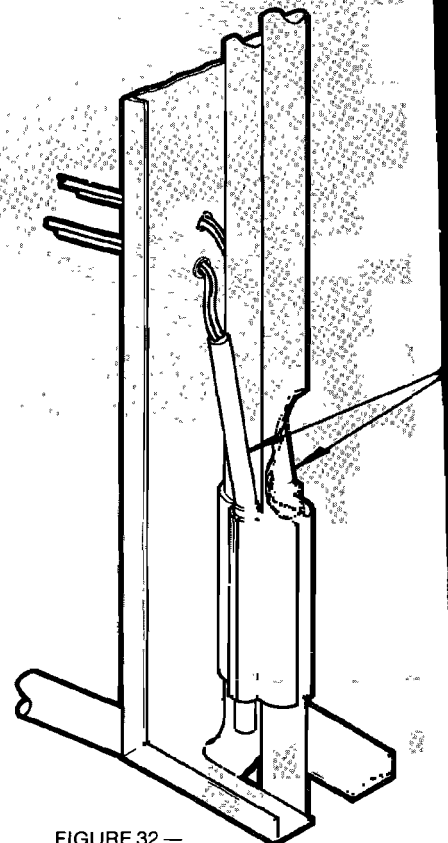

FIGURE 32 —
DOUBLE ELEMENT
CAMPING FREEZE (TH) BOILER BOX

3. Make sure the heater is inserted at the bottom of the well pocket.
4. Be careful placing the insulation in its proper position again after replacement.

NOTE

The edges of the opening in the cover may be sharp! Be careful!

WIRING DIAGRAM

**Heating element for IM-42
Part #330-135**

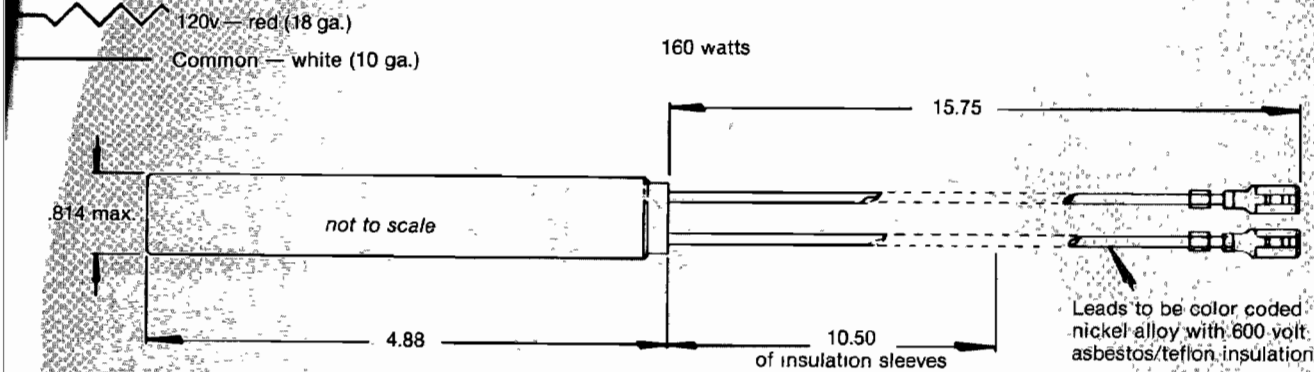

Wire terminals to be .250 x .032 insulation support receptacles.

All elements must meet U.L. requirement 1030

WIRING DIAGRAM

**Heating element for IM-43
Part #330-191**

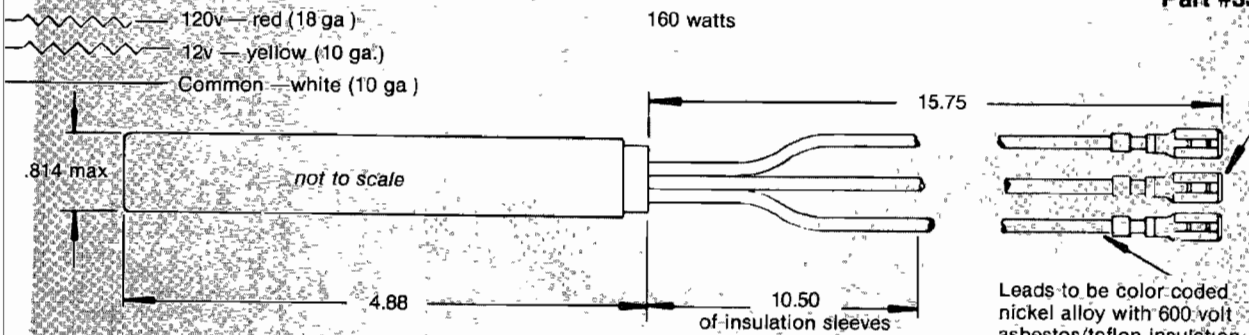

Wire terminals to be .250 x .032 insulation support receptacles.

All elements must meet U.L. requirement 1030

WIRING DIAGRAM

**Heating element for IM-62 Siam
Part #330-094**

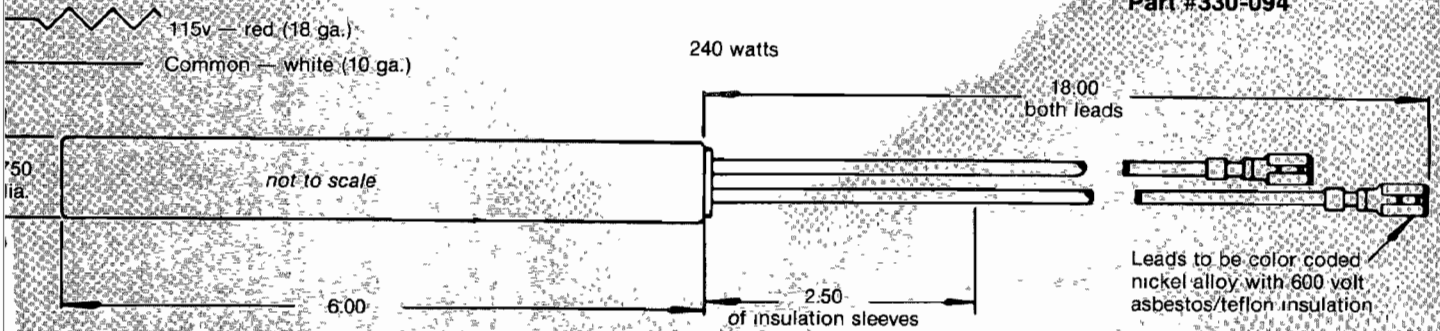

Wire terminals to be .250 x .032 insulation support receptacles.

All elements must meet U.L. requirement 1030

WIRING DIAGRAM

Heating element for IM-62 C
Part #330-238

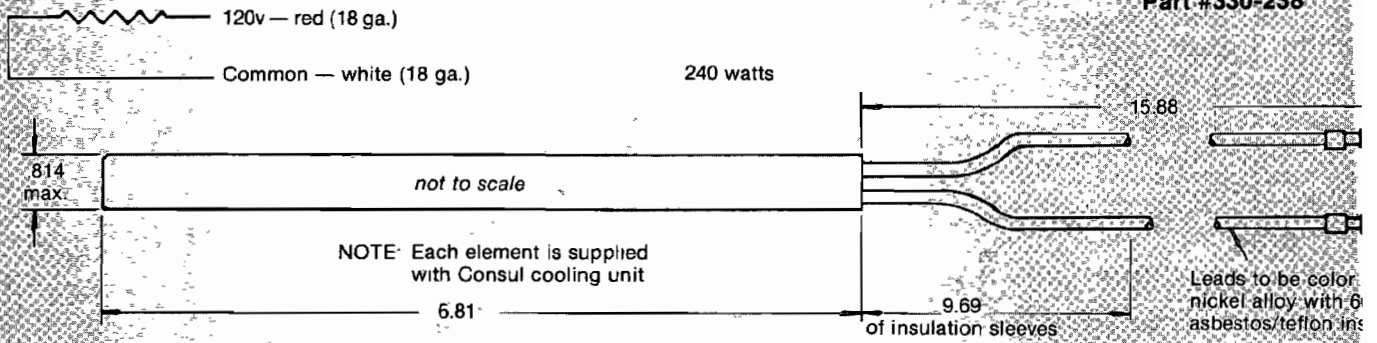

Wire terminals to be .250 x .032 insulation support receptacles

All elements must meet U.L. requirement 1030

WIRING DIAGRAM

Heating element for IM-63
Part #330-016

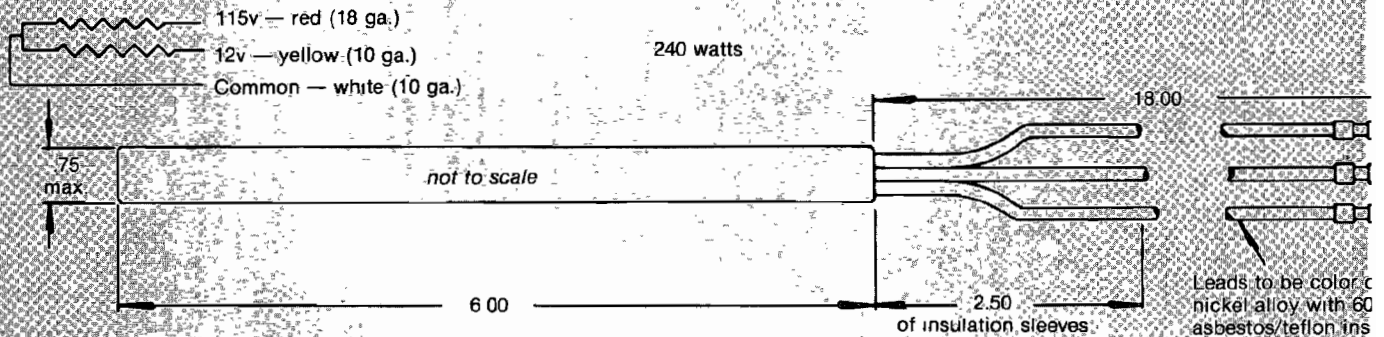

Wire terminals to be .250 x .032 insulation support receptacles

All elements must meet U.L. requirement 1030

WIRING DIAGRAM

Heating element for IM-63 C
Part #330-110

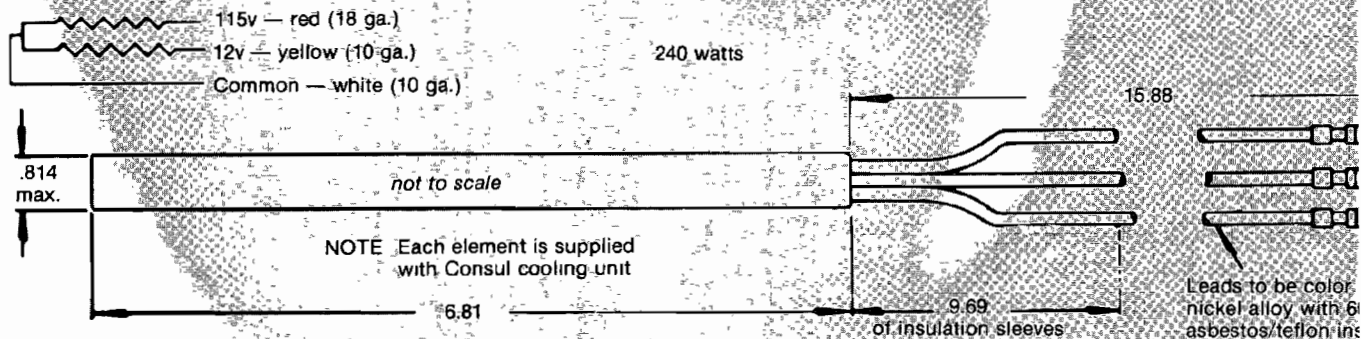

Wire terminals to be .250 x .032 insulation support receptacles

All elements must meet U.L. requirement 1030

WIRING DIAGRAM

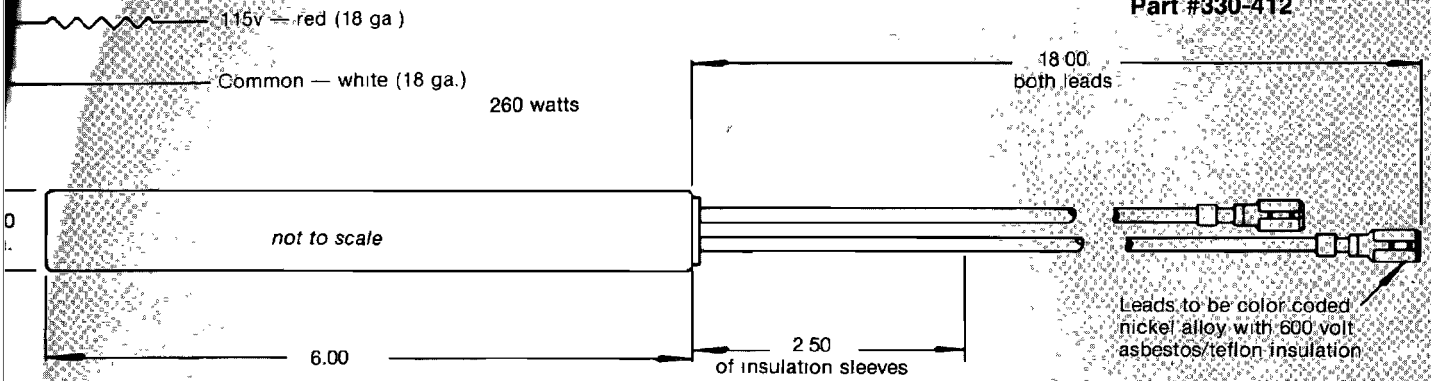

Heating element for IM-72 Siam Part #330-412

Wire terminals to be .250 x .032 insulation support receptacles

All elements must meet U.L. requirement 1030

WIRING DIAGRAM

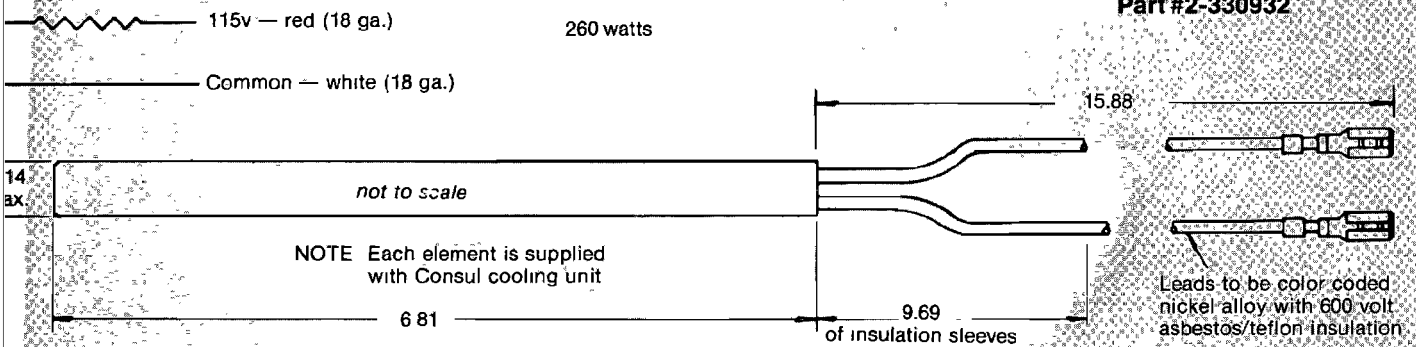

Heating element for IM-72 Consul Part #2-330932

Wire terminals to be .250 x .032 insulation support receptacles

All elements must meet U.L. requirement 1030

WIRING DIAGRAM

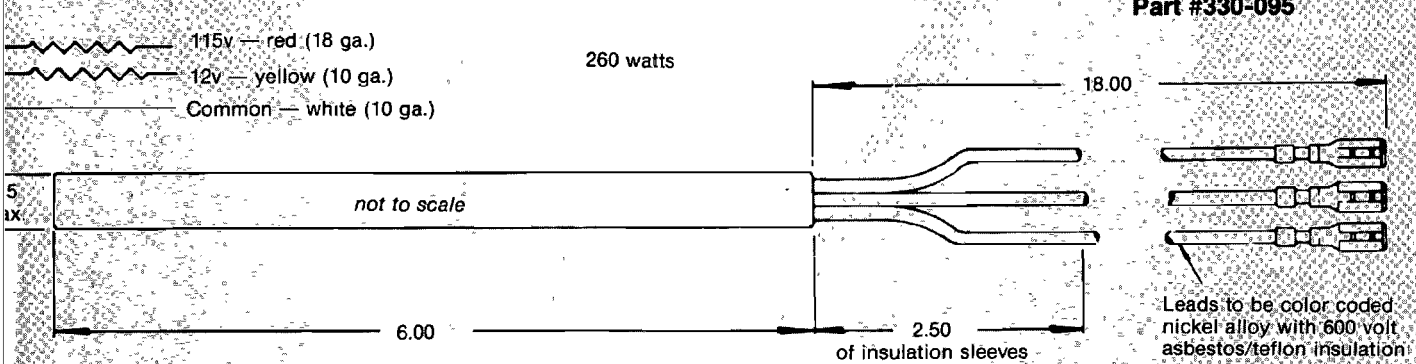

Heating element for IM-73 Siam Part #330-095

Wire terminals to be .250 x .032 insulation support receptacles

All elements must meet U.L. requirement 1030

WIRING DIAGRAM

Heating element for IM-73 Consul Part #2-330933

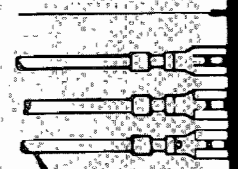
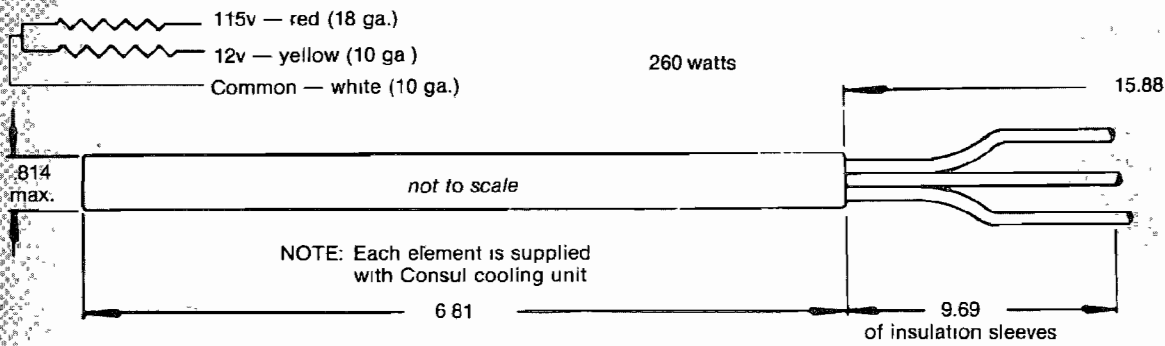

Leads to be color coded nickel alloy with 600°C asbestos/teflon insulation

Wire terminals to be .250 x .032 insulation support receptacles

All elements must meet U.L. requirement 1030

WIRING DIAGRAM

Heating element for IM-92 Consul Part #2-330932

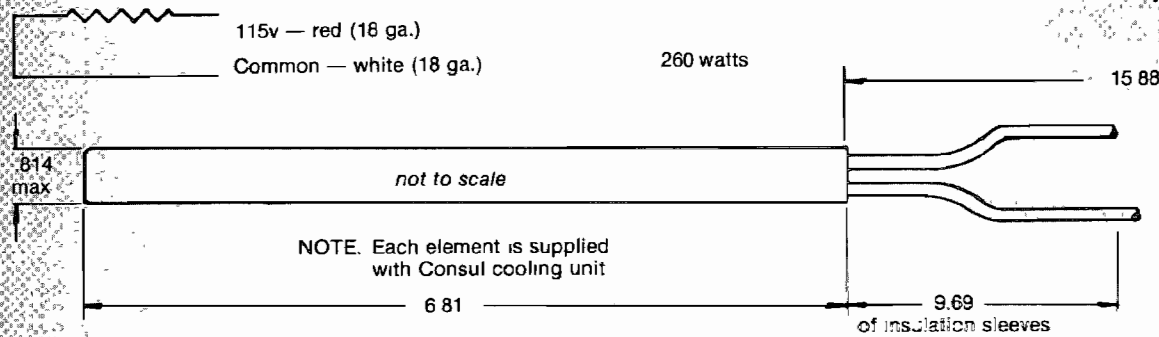

Leads to be color coded nickel alloy with 600°C asbestos/teflon insulation

Wire terminals to be .250 x .032 insulation support receptacles

All elements must meet U.L. requirement 1030

WIRING DIAGRAM

Heating element for IM-93 Consul Part #2-330933

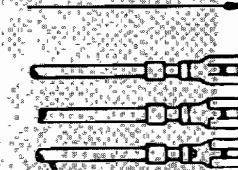
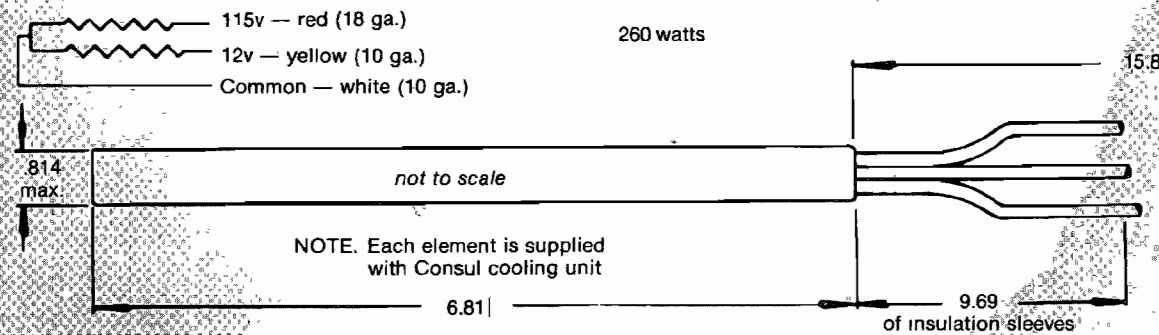

Leads to be color coded nickel alloy with 600°C asbestos/teflon insulation

Wire terminals to be .250 x .032 insulation support receptacles

All elements must meet U.L. requirement 1030

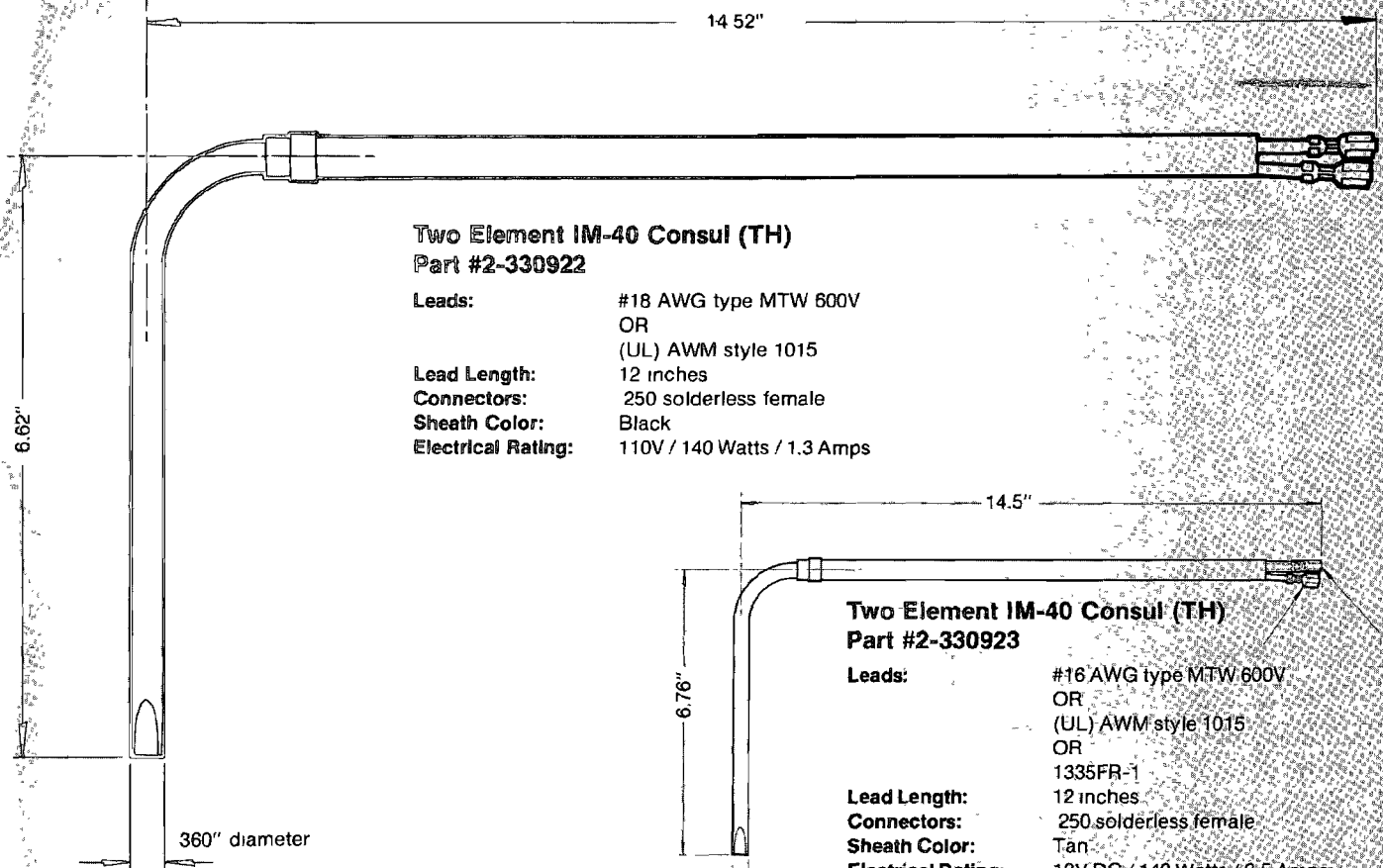

Two Element IM-40 Consul (TH)
Part #2-330922

Leads: #18 AWG type MTW 600V
 OR
 (UL) AWM style 1015
Lead Length: 12 inches
Connectors: 250 solderless female
Sheath Color: Black
Electrical Rating: 110V / 140 Watts / 1.3 Amps

Two Element IM-40 Consul (TH)
Part #2-330923

Leads: #16 AWG type MTW 600V
 OR
 (UL) AWM style 1015
 OR
 1335FR-1
Lead Length: 12 inches
Connectors: 250 solderless female
Sheath Color: Tan
Electrical Rating: 12V DC / 140 Watts / 2.5 Amps

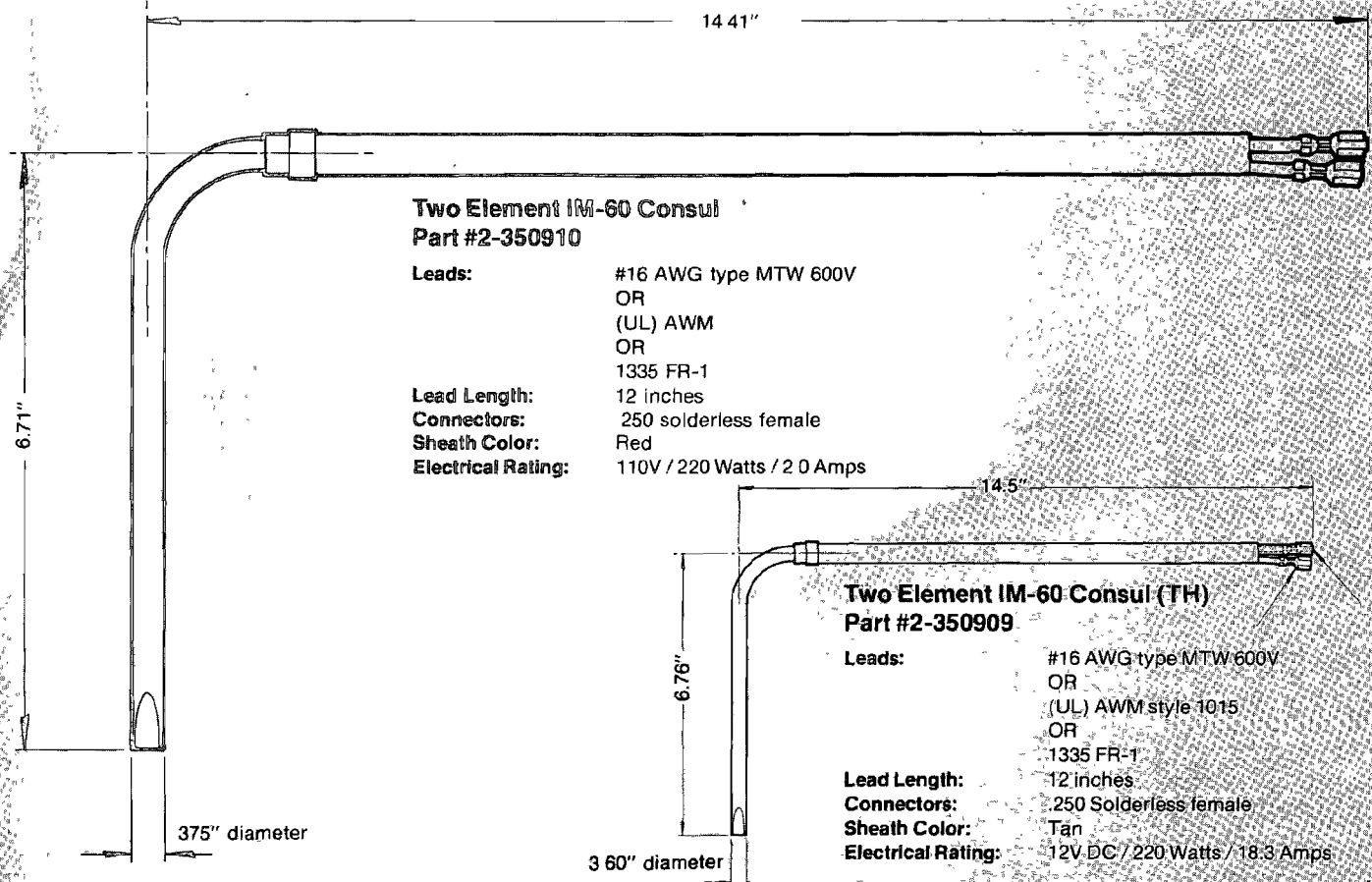

Two Element IM-60 Consul
Part #2-350910

Leads: #16 AWG type MTW 600V
 OR
 (UL) AWM
 OR
 1335 FR-1
Lead Length: 12 inches
Connectors: 250 solderless female
Sheath Color: Red
Electrical Rating: 110V / 220 Watts / 2.0 Amps

Two Element IM-60 Consul (TH)
Part #2-350909

Leads: #16 AWG type MTW 600V
 OR
 (UL) AWM style 1015
 OR
 1335 FR-1
Lead Length: 12 inches
Connectors: 250 Solderless female
Sheath Color: Tan
Electrical Rating: 12V DC / 220 Watts / 18.3 Amps

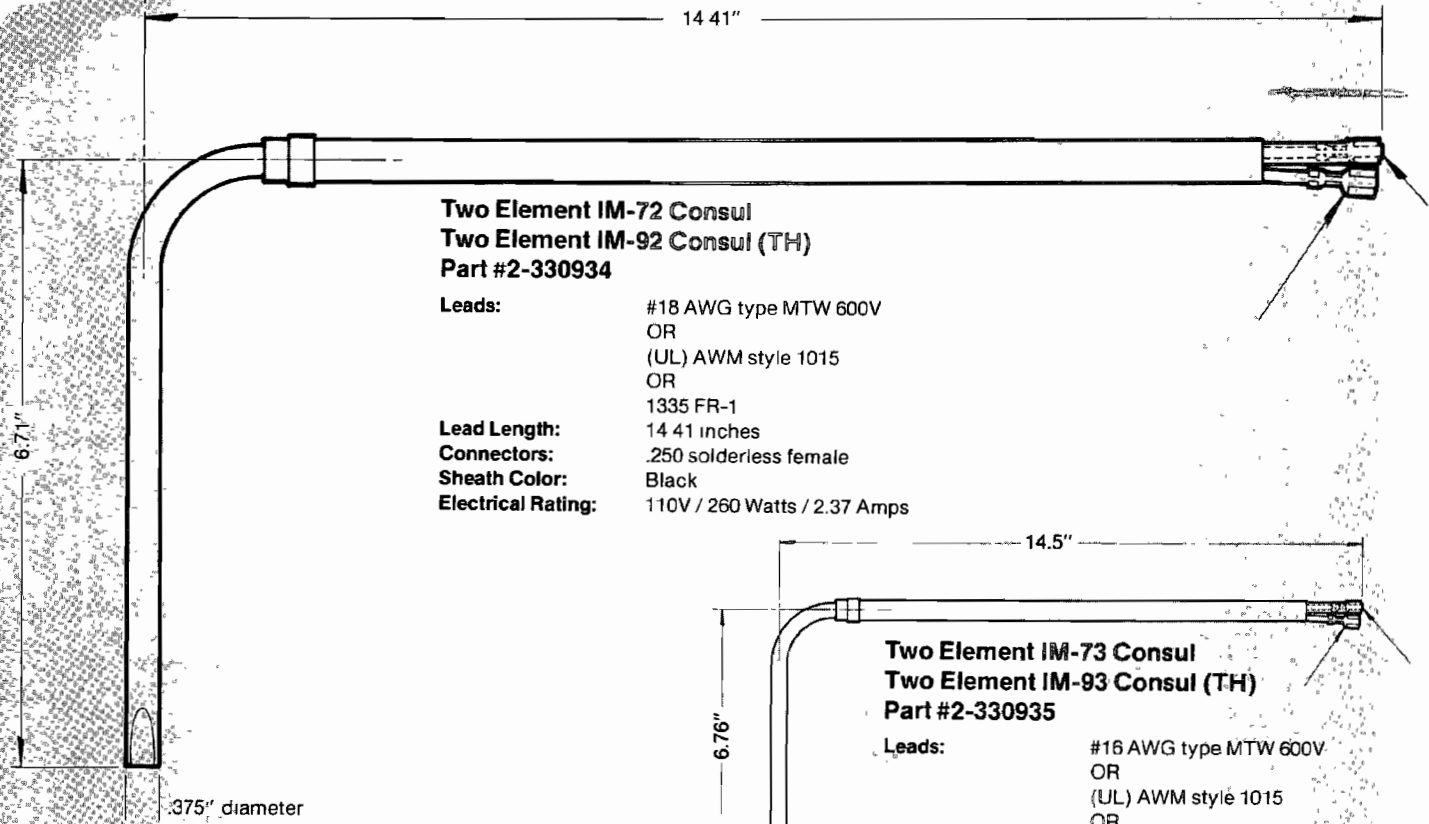

**Two Element IM-72 Consul
Two Element IM-92 Consul (TH)
Part #2-330934**

Leads: #18 AWG type MTW 600V
OR
(UL) AWM style 1015
OR
1335 FR-1

Lead Length: 14.41 inches

Connectors: .250 solderless female

Sheath Color: Black

Electrical Rating: 110V / 260 Watts / 2.37 Amps

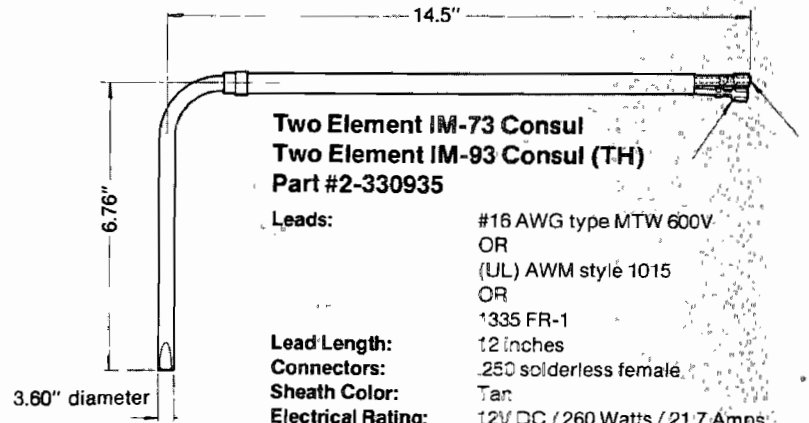

**Two Element IM-73 Consul
Two Element IM-93 Consul (TH)
Part #2-330935**

Leads: #16 AWG type MTW 600V
OR
(UL) AWM style 1015
OR
1335 FR-1

Lead Length: 12 inches

Connectors: .250 solderless female

Sheath Color: Tan

Electrical Rating: 12V DC / 260 Watts / 21.7 Amps

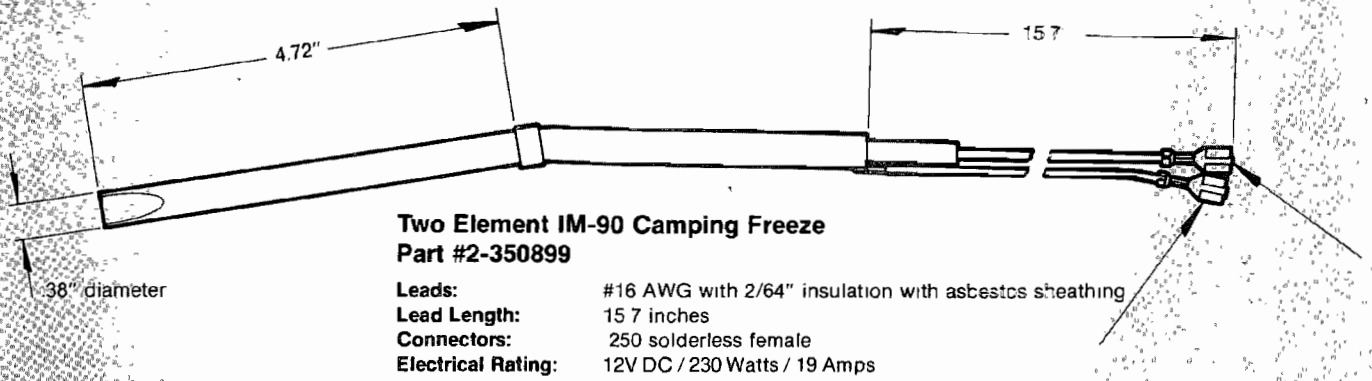

**Two Element IM-90 Camping Freeze
Part #2-350899**

Leads: #16 AWG with 2/64" insulation with asbestos sheathing

Lead Length: 15.7 inches

Connectors: .250 solderless female

Electrical Rating: 12V DC / 230 Watts / 19 Amps

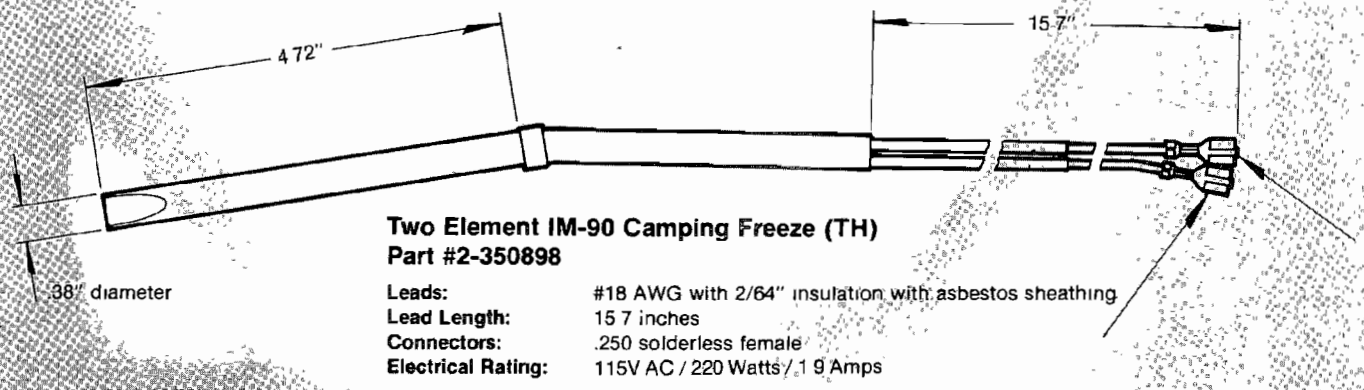

**Two Element IM-90 Camping Freeze (TH)
Part #2-350898**

Leads: #18 AWG with 2/64" insulation with asbestos sheathing

Lead Length: 15.7 inches

Connectors: .250 solderless female

Electrical Rating: 115V AC / 220 Watts / 1.9 Amps

Innovator Operation Analysis for Gas

WARNING: Tampering with cooling unit will void warranty . . .

CONTENTS HIGHLY FLAMMABLE AND TOXIC.

SYMPTOM							CAUSE
Refrigerator too cold	Refrigerator not cold enough	Lack of refrigeration	Frost forms rapidly	Burner flame goes out	Odor inside cabinet	Odor outside cabinet	NOTE: It will be noted in this tabulation that several causes can be responsible for the one effect. The real cause or causes should be determined by a process of elimination, investigating each possible cause, proceeding to the bottom.
					●		Gas leaks pages 5, 11
	●	●					Inadequate ventilation pages 8, 10
	●	●					Unit not level page 8
	●	●	●				Orifice clogged (Replace) page 23
			●				Thermocouple tip improperly located pages 11, 13, 23
				●			Improper contact between thermocouple and safety control magnet pages 11, 23
				●			Faulty safety control magnet (replace control) page 25
	●	●					Improper maximum flame pages 12, 20
	●	●	●				By-pass flame too small page 11
	●		●				By-pass flame too large page 20
	●	●		●			Improper position of the flue baffle figure 21, page 13
	●	●					Unstable burner flame pages 8, 11
	●	●					Improper food storage page 10
			●				Improper storage of liquid and moist foods page 10
	●	●	●				Leaky door gaskets page 10
	●	●	●		●		Obstructed flue pages 11, 12
					●		Burner mis-alignment with flue tube page 13
					●		Insufficient primary air (see "Installation") pages 5, 6, 7
					●		Infrequent cleaning of food compartment page 10
					●		Refrigerator shut off with closed door page 10
					●		Unwrapped odorous food page 10
	●		●				Incomplete contact of thermostat tube page 11
	●	●					Lost thermostat charge page 11
	●	●					Defective cooling unit (Refer to "Things to Do") page 47
	●						Room temperature too low page 3

Innovator Operation Analysis for Electric

**WARNING: Tampering with cooling unit will void warranty . . .
CONTENTS HIGHLY FLAMMABLE AND TOXIC.**

SYMPTOM		CAUSE
Refrigerator too cold Refrigerator not cold enough Lack of refrigeration Frost forms rapidly Odor inside cabinet		NOTE: It will be noted in this tabulation that several causes can be responsible for one effect. The real cause or causes should be determined by a process of elimination, investigating each possible cause, starting at the top of the tabulation and proceeding to the bottom.
● ●		Inadequate ventilation pages 8, 9, 10
● ●		Refrigerating unit not level page 8
● ●		Heater faulty, wrong voltage or type pages 39-44
● ●		Inconsistent voltage (under "Tips on Cooling Unit Analysis") page 8
●	●	Electric connections loose (under "Trouble Shooting Chart") page 24
● ●		Element not inserted correctly in its pocket page 38
● ●		Improper food storage page 10
●	●	Improper storage of liquids and moist foods page 10
● ● ●		Leaky door gaskets page 10
●	●	Infrequent cleaning of food compartment page 10
●	●	Refrigerator shut off with closed door page 10
●	●	Unwrapped odorous food page 10
●	●	Incomplete contact of sensing tube page 22
● ●		Lost thermostat charge page 11
● ●		Defective cooling unit (see "Things to Do") page 47
●		Room temperature too low page 3