



INSTA-MATIC
GAS/ELECTRIC

REFRIGERATORS FOR LP-GAS AND ELECTRIC OPERATION

OPERATING INSTRUCTIONS Page 4-7

INSTALLATION Page 8-11

East

**INSTAMATIC
Division LaSalle
Deitch Co., Inc.
Post Office Box 456
Elkhart, Indiana 46514**

West

**INSTAMATIC
Division LaSalle
Deitch Co., Inc.
17051 East Green Drive
City of Industry, California 91744**

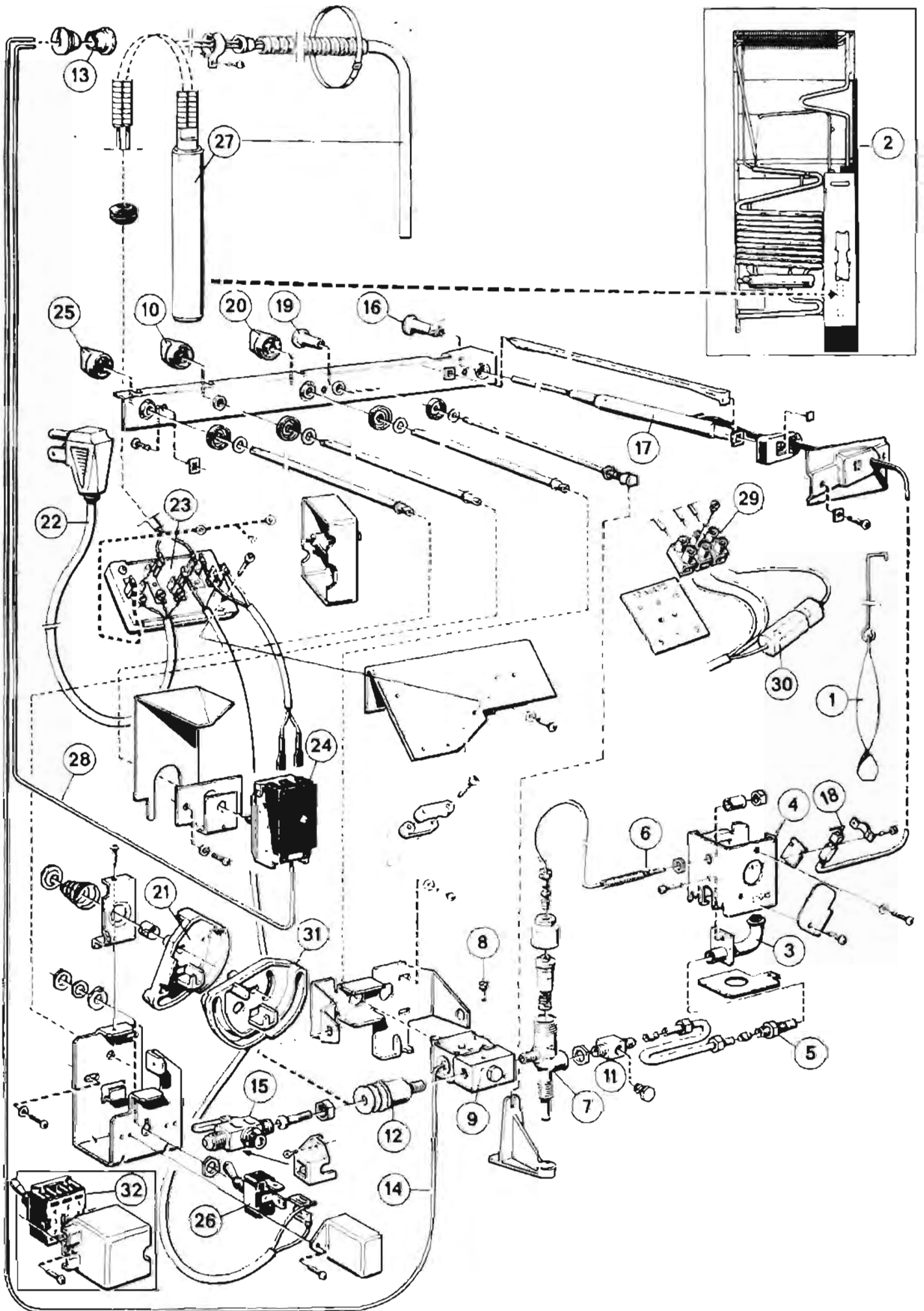

Fig. 1

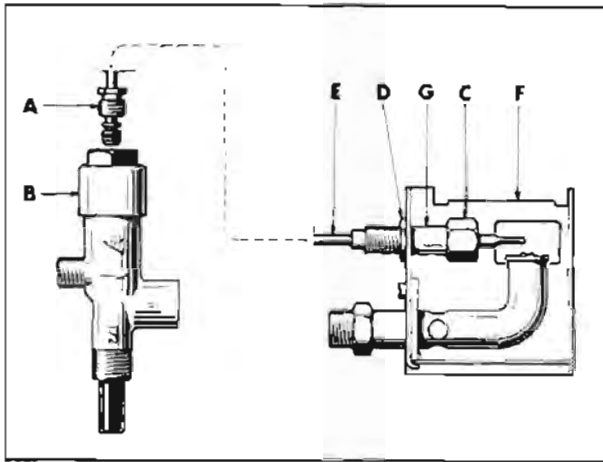

Fig. 2

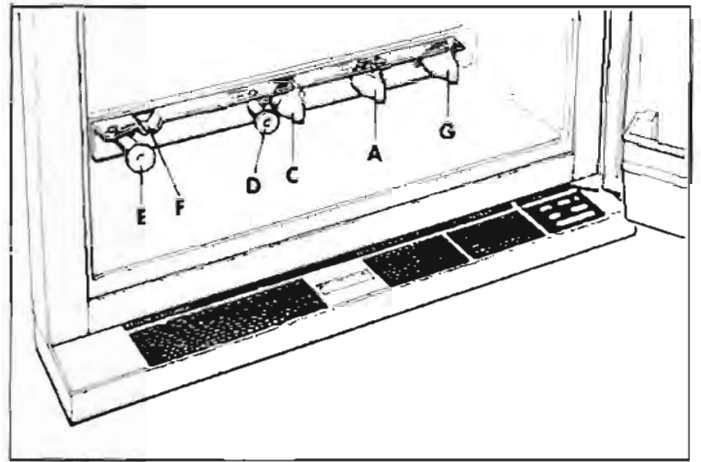

Fig. 4

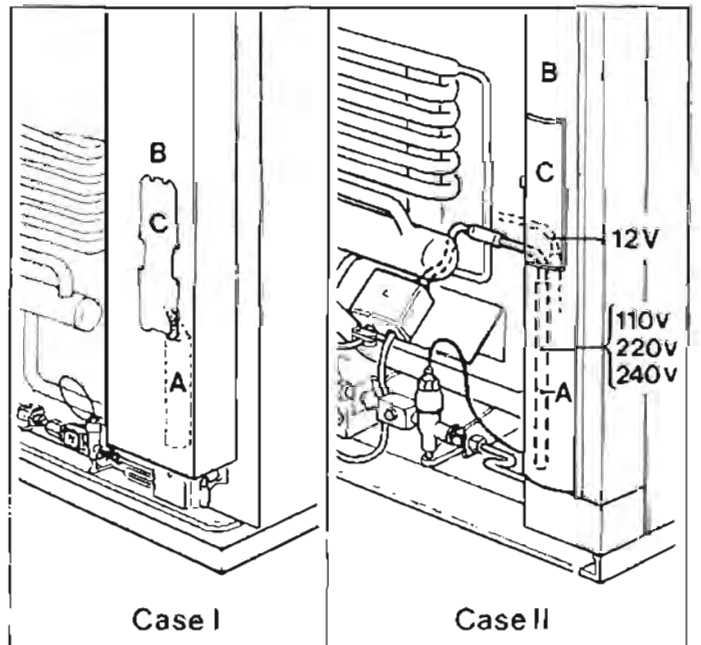

Fig. 5

Gas equipment parts

- 1 Flue baffle
- 2 Blow out protection
- 3 Burner tube
- 4 Burner housing
- 5 Burner jet
- 6 Feeler point
- 7 Flame failure safety device
- 8 By-pass screw
- 9 Gas thermostat
- 10 Knob for fuel selector
- 11 Pressure test gage connection
- 12 Gas filter
- 13 Plugs for capillary tubes
- 14 Capillary tube for gas thermostat
- 15 Shut-off valve
- 16 Push button for lighter
- 17 Piezo lighter
- 18 Lighter electrode
- 19 Knob for releasing safety device
- 20 Knob for gas thermostat
- 21 Fuel selector, LP-gas/110 Volts A.C.

Electric equipment parts

- 22 Flexible cord with molded plug
- 23 Junction box
- 24 Electric thermostat
- 25 Knob for electric thermostat
- 26 Toggle switch - 110 Volts operation
- 27 Heater
- 28 Capillary tube for electric thermostat

12 Volts operation, available for certain refrigerator models.

- 29 Terminal block
- 30 Fuse
- 31 Fuel selector, LP-gas/110 Volts A.C./12 Volts D.C.
- 32 Change-over switch, 110 Volts A.C./12 Volts D.C.

INSTRUCTIONS FOR USE

INSTALLATION OF REFRIGERATOR IN VEHICLE

The refrigerator must be installed on a solid floor and must be level. With the vehicle carefully leveled, the refrigerator should level both ways in the freezer compartment. (More about leveling is to be found under the heading "How to start the refrigerator".)

Free air circulation over the fins of the cooling unit is essential. Clearances around the refrigerator should be in accordance with the label attached to the bottom plate below the door.

In case detailed instructions on the installation and connection to the gas supply are required, contact your dealer or distributor.

To change the door opening from left to right or vice versa

Unscrew and remove the upper hinge bolt. Incline the door outwards and lift off the door. Check that washer and nylon bushings are in the right position. The lower hinge bolt should then be moved to the opposite side. Refit the door and upper hinge bolt.

Check that the door closes easily and that the gasket seals well on all sides. If necessary, adjust by resetting the top hinge.

INSTALLATION page 8—11

WARNING

If the refrigerator is used intermittently it should be checked at least once a year.

HOW TO START THE REFRIGERATOR

Leveling

In the boiler ammonia vapor is distilled from an ammonia-water mixture and carried to the finned condenser, where it liquifies. The liquid flows to the evaporator, where it creates cold by evaporating into a circulating flow of hydrogen gas. If the evaporator coil is not level the liquid readily accumulates, forming pockets which can impair the gas circulation or even block it, in which case, of course, the cooling will stop.

When the recreational vehicle is stationary it must be leveled to be comfortable to live in. If the refrigerator is properly installed, i.e. the freezer shelf parallel to the floor, the refrigerator will then also perform well.

A bubble level should be placed on the freezer shelf.

When the vehicle is on tow, the continuous rolling and pitching movement will not affect the refrigerator as long as the movement passes either side of level, but when the trailer is temporarily parked this sensitivity of the refrigerator should be remembered. So, once more, before you start the refrigerator make sure it is level.

Gas operation (Fig. 4)

1. To start the refrigerator turn the knob A to position "Gas". The gas valve is now opened and the electric circuits are broken.
2. Turn the gas thermostat knob C to setting 4.

3. Pull the knob D of the flame failure safety device and press the button E of the piezo lighter. The pressing of the button E has to be repeated until the gas is lit at the burner. Through the reflector F it can be observed that the burner is lit.
4. After the gas is lit keep the knob D in pulled out position for 15 seconds. Then release the knob and check through the reflector that the burner flame stays burning.

Note: After a replacement of the gas container or a long shut-off period the gas line is likely to be filled with air. In such a case the lighting procedure has to be repeated until the air is pushed out of the line and the gas has reached the burner.

Electric operation (Fig. 4)

1. Check that the attachment plug of the flexible cord is correctly connected to the mains supply. When the refrigerator is equipped also for 12 V D.C. operation the low voltage connection is made at the marked terminals at the rear of the refrigerator.
2. Turn the knob A to "off" position then press the knob to the bottom and turn to desired electric position.
3. Turn the thermostat knob G to setting 4.

Note: When the refrigerator is equipped for 110 Volts and 12 Volts operation the turning movement of the knob A should be made as follows:

In Gas OFF position the knob is pressed and turned clockwise to position 12 Volts. If 110 Volts operation is desired press once more and continue the clockwise turning to position 110 Volts.

HOW TO USE THE REFRIGERATOR

Food storage compartment

The food storage compartment is completely closed and unventilated, which is necessary to maintain the required low temperature for food storage. Consequently foods having a strong odor or liable to absorb odors should be covered. Vegetables, salads, etc., should be covered to retain their crispness. The coldest positions in the refrigerator are underneath the cooling evaporator and at the bottom of the refrigerator, and the least cold positions are on the upper door shelves. This should be considered when different types of food are placed in the refrigerator.

Defrosting

Some refrigerator models are equipped with an automatic defrosting device incorporated with the cooling unit. This device makes a quick defrost of the finned evaporator section about once a day without affecting the frozen food storage compartment or the frozen foods contained in it. When the frozen food storage compartment is covered with frost the cabinet must be shut down temporarily till the frost is melted. Before the refrigerator is restarted the compartment should be dried, the ice trays washed and refilled with fresh water.

When the frost on the finned evaporator section has melted water will be collected in the drip tray. The drip tray should be emptied at regular intervals.

Some refrigerators without the automatic defrosting device should be defrosted regularly by turning off the refrigerator.

Empty the refrigerator leaving the drip tray under the finned evaporator and the cabinet and freezer doors open. If desired, defrosting may be speeded up by filling the ice tray with hot water and placing it in the freezer. When all frost is melted, empty the drip tray and dry the interior of the refrigerator with a clean cloth. Replace the shelves, drip tray and ice tray, replace all food stuffs and set the thermostat to MAX for a few hours. Then reset the thermostat knob to its normal position.

Frozen food storage compartment

The ice trays should be placed in direct contact with the freezer shelf for fastest ice making. Quick frozen soft fruits and ice cream should be placed in the coldest part of the compartment which is at the bottom of the aluminium liner or, in models with a shelf, on this or just below it. Frozen vegetables, on the other hand, may be stored in any part of the compartment.

The compartment is not designed for the deep or quick freezing of foodstuffs. Meat or fish foods, whether raw or prepared, and provided they are precooled in the refrigerator, can however also be stored in the frozen food storage compartment. They can then be stored about three times as long as in the normal temperature compartment. To prevent drying out, keep food in covered dishes, in plastic bags or wrapped in aluminium foil.

Ice making

Ice cubes can be made in the ice trays which should be filled with water to within 1/4 inch (5 mm) from the top. To release the ice cubes the handle should be pulled upwards. Cubes not required should be replaced in the tray. Refill the tray with water, dry the outside, and replace it in the frozen storage compartment.

Ice making is accelerated if the thermostat is set to MAX. It is a good idea to do this a few hours before an anticipated need for ice, but be sure to turn back the thermostat to its original setting when the ice is formed, or the foodstuffs in the cabinet may become frozen hard. The ice making time is also reduced if unused cubes are left in the ice trays when they are refilled with water.

To shut down the refrigerator

To shut down the cabinet temporarily, set the thermostat to zero and turn off the gas tap. If the cabinet is not in operation, over a period of weeks, it should be emptied and cleaned, and the door left ajar. The ice trays should also be dried and kept outside the cabinet.

Cleaning

To clean the interior lining of the cabinet, use lukewarm weak soda solution. The evaporator, ice trays and shelves must, however, be cleaned with warm water only. Never use strong chemicals or abrasives to clean these parts or the protective surface will be spoiled. It is important always to keep the cabinet clean.

CAUTION. Do not store explosive substances in the refrigerator such as cigarette lighter gas, petrol, ether or the like.

GAS EQUIPMENT

Flue top and baffle (Fig. 1)

The flue baffle is suspended from the top and must be in position in the central tube of the cooling unit.

The burner and the by-pass screw

The burner must be centrally located under the boiler tube.

To change or clean the burner jet, first loosen the gas pipe from the burner, then unscrew the jet from the burner base. On delivery the burner is normally fitted with a jet for Propane gas and when using Butane one must fit another jet size according to the spare parts list. Sizes are stamped on the jet.

The orifice in the jet is very small. It must never be cleaned by means of a pin or similar instrument, as this would enlarge or damage the orifice. Should, for some reason, the jet require cleaning it should be blown through or washed in alcohol.

The by-pass screw is accessible at the top of the thermostat (see illustration).

The gas thermostat

The refrigerator is equipped with a thermostat which is regulated by turning the knob to different settings in order to obtain the desired controlled cabinet temperature.

At zero (indicated by a dot) Under normal operating conditions the thermostat valve remains closed and the burner is running continuously at the by-pass rate, just enough to keep the burner lit.

At MAX The thermostat valve remains open and the burner is running continuously at full gas rate. Lowest cabinet and freezer temperatures are obtained at this setting.

Between these two extremes is a numbered portion of the dial over which various controlled temperatures can be obtained, the higher the number, the lower the temperature.

As soon as the required cold temperature inside the cabinet is reached, the thermostat cuts the burner main flame leaving the by-pass flame to keep the safety valve open.

Flame blow out

If trouble is encountered with the flame blowing out under specially windy conditions, try to avoid the wind blowing against the wall where vent outlets are located. If the trouble persists, set the thermostat to MAX. This later measure can of course only be temporary such as when the caravan is on tow, for after a day or so at this setting the foodstuffs in the cabinet will freeze.

Periodic maintenance (Fig. 1)

NOTE. Before working on the refrigerator make sure that 110 V.A.C. and optional 12 V.D.C. leads are disconnected.

Once or twice a year depending on use, it is necessary to clean and adjust the burner assembly. Proceed as follows:

1. Disconnect the gas pipe from the burner assembly.
2. Remove the burner bracket.
3. Remove the burner housing.
4. Clean the jet with alcohol and compressed air ONLY.
5. Clean the burner tube and especially the gauze with a brush. Blow with compressed air.
6. Reassemble.
7. Check the burner with full flame (turn thermostat to MAX) and with by-pass flame (if the refrigerator has been working for a few hours and the thermostat bulb is colder than about 6°C or 43°F the transition from full flame to by-pass can be observed if one turns the thermostat knob slowly from MAX to zero).

At the same time, check the flue baffle: that it is clean and reasonably free from soot. Heavy soot formation indicates improper functioning of the burner. Clean baffle and flue. For details on cleaning, see under heading "Odor from fumes", section d. Further, clean cooling unit and floor under refrigerator.

The entire gas installation should be checked for leaks at intervals. Test all pipe connections with soapy water, not with an open flame.

How to replace the thermo-element of the flame failure safety device

(Fig. 2)

1. Unscrew plug A from the valve housing B.
2. Loosen the position nut C and lock nut D.
3. Screw off nut C and release the thermo-element E from bracket F. Remove nut D.
4. Bend the new thermo-element to the same shape as the old one. Screw nut D into the new element.
5. Put the feeler through the hole in bracket F, refit the distance element G and screw the position nut tight against a shoulder on the feeler itself, making sure the nut D is free during this operation.
6. Tighten the lock nut D against the bracket with a spanner, if necessary holding nut C with another spanner. Make sure the feeler is located as in fig. 4.
7. Screw plug A onto the valve housing taking care not to damage the threaded hole in the aluminium cap of the housing. Plug A must be properly tightened to the valve housing to ensure good contact between the thermo-element and the magnetic coil within the housing.

The lighter

The refrigerator is fitted with a piezo lighter, which does not normally need any maintenance. If the lighter does not work properly contact an authorized service point.

ELECTRIC EQUIPMENT

Heater

On electrically operated refrigerators heat is supplied by an electric heater (A) mounted in the boiler on the cooling unit inside the cover (B). When the heater has to be replaced different procedures have to be followed depending on the construction.

The boiler casing normally is fitted with a blow out protection arrangement which has to be removed before the boiler cover is fully accessible.

Case I (Fig. 4)

To replace the heater, first of course check that the wall plug is disconnected, then remove the shutter (C) and enough rock wool insulation around the heater to make possible its extraction. Then bend aside the wire keeping the heater in proper position, disconnect the heater leads from the cord and remove the heater. Make sure the new heater is fully inserted before bending back the lock wire (with caution, or it might snap off). Reset the electric connections and the plastic insulation sleeves. Be careful to put the rock wool insulation back in its proper place and in such a way that the heater leads will not be in direct contact with hot boiler tubes. Be careful to put the insulation back in its proper place before refitting the shutter. Note: The edges of the opening in the cover may be sharp.

Case II (Fig. 5)

To replace the heater, first of course check that the wall plug is disconnected. Then proceed as follows:

- a) Remove the protection plate at the rear of the refrigerator.
- b) Disconnect the heater leads from the junction box.
- c) With a pair of pliers unfold the lug holding the lid of the boiler casing and open the lid.
- d) Move aside as much of the boiler insulation as is necessary for access to the heater pocket.
- e) Pull the heater upwards and remove it from the pocket.
- f) When the heater has been replaced adjust the boiler insulation carefully and close the lid. Bend the lug so that the lid is locked in closed position.
- g) Connect the heater leads to the junction box and refit the protection plate.

Switch

The electric control device also comprises an on-off switch operated by the fuel selector from the control panel.

Electric thermostat

The temperature in the refrigerator can be regulated by turning the thermostat knob to higher or lower numbers. Although the exact setting is not critical, it will usually be found suitable to choose a setting at which the frost, which gradually forms on the cooling evaporator is just maintained in dry condition.

It will be necessary to set the thermostat knob one or two numbers higher when the ambient temperature becomes higher or the load unusually heavy.

If less cooling is required, a lower setting should be chosen. No attempts at adjusting the thermostat should be made.

FAULT TRACING

The refrigerator does not freeze satisfactorily

Causes and remedies

- a) Jet orifice clogged. Disengage gas pipe from burner. Unscrew nipple with jet and blow clear and wash in alcohol. Do not use wire or pin to clean orifice.
- b) Check the leveling of the refrigerator.
- c) Flame has gone out. Remedy: 1) Gas in bottle is used up – refill. 2) Feeler point of the flame failure safety device is not heated enough by flame – check against fig. 4. 3) Clogged by-pass screw – clean or exchange it.
- d) Air circulation around cooling unit is restricted. Be sure that refrigerator is properly ventilated.
- e) The evaporator is heavily coated with frost. Defrost.

- f) Flue baffle not inserted into the central tube of the cooling unit.
- g) The thermostat is incorrectly used. See paragraph on thermostat. In hot weather the setting should be one or two numbers "colder" than usual.
- h) Gauze in burner head clogged. Clean.
- i) Burner damaged. Replace.
- j) Burner may be dislocated. Relocate.
- k) Wrong gas pressure at the burner. Have pressure checked at burner and at gas bottle. Pressure at burner must not fall below 11" W.G. when thermostat is set on MAX.
- l) Improper operation of the thermostat. Check the position of the capillary tube between the evaporator fins. The end of the capillary tube must be in proper direct contact with the evaporator. (This contact is achieved in two different ways: (1) The capillary tube is inserted in a spring-clip which is fastened between two fins (2). The capillary tube is fastened between two fins with a sheet brace and two screws). If the position of the capillary tube end is not correct, adjust accordingly. If no improvement is obtained, exchange the thermostat.

ODOR FROM FUMES

Causes and remedies

- a. The flame touches side of the boiler due to dislocation of the burner. Relocate. Burner dislocation may also cause smoke and discoloring of walls and ceiling.
- b. Burner damaged. Replace.
- c. The flame touches flue baffle. Remedy: 1) Burner damaged. Replace. 2) Flue baffle too low. Correct the position of the baffle.
- d. The flue tube is dirty. Clean flue as follows: Cover burner and jet. Remove flue top and baffle. Clean flue with special flue brush. Clean baffle before putting back in place.

All the above instructions are to be followed closely. The refrigerator is quality-guaranteed. However, we are not responsible for any failures caused by improper adjustments and unfavorable installation conditions. Contact service point or distributor service dept. for assistance.

INSTALLATION



GENERAL INSTRUCTIONS

The refrigerators outlined hereon have been design certified under ANSI Z 21.9 Refrigerators by the American Gas Association for installation in a mobile home or recreational vehicle and are approved by The Canadian Gas Association.

The certifications are, however, contingent on the installation being made in accordance with the following instructions.

The installation must in the USA conform with

1. National Fuel Gas Code, Z223.1-1974.
2. Mobile Homes A 119.1-1969
3. Recreational Vehicles A 119.2-1970

The unit must be electrically grounded in accordance with the National Electrical Code ANSI, C1-1968, when installed if an external alternating current electrical source is utilized.

4. Any applicable local code

In Canada:

1. Standard CGA B149.2 "Installation Code for Gas Burning Appliances and Equipment"
2. Standard CGA 10.1/Z240.4 "Gas equipped mobile homes and recreational vehicles".

be plugged directly into a properly grounded three prong receptacle. Do not cut or remove the grounding prong from this plug. The cord should be routed to avoid coming in contact with the burner cover, flue cover or other hot components.

12 V.D.C., optional for certain models.

On "Tri-Power" units there is an additional terminal block marked "12 V". The refrigerator must be connected to the battery circuit with two wires of adequate capacity to avoid voltage drop. The wire gage should be chosen with consideration to the wire length in accordance with the following table

The 12V circuit must be fused with an appropriate fuse.

TABLE

Maximum two conductor wire length for different AWG numbers

MAXIMUM TWO CONDUCTOR WIRE LENGTH IN FEET

AWG	IM-3 120W	IM-4 135W	IM-6 160W	IM-7 225W
14	10	9	7	6
12	17	15	12	9
10	27	25	19	15
8	43	40	31	24
6	69	64	49	38
4	110	102	79	61

Do not use the body or chassis of the vehicle as a substitute for either of the two conductors. No other electrical equipment or lighting should be connected to the refrigerator circuit. The refrigerator will draw from 8 to 17 Amps at 12 Volt depending on model.

CAUTION

Do not operate the refrigerator on 12 Volt when the vehicle is parked. You will run out of battery in a rather short time.

If possible the installation of a 12 Volt operated refrigerator should be completed with a relay mounted either in the car or in the recreational vehicle (see Fig 7 below). This relay will automatically cut out the refrigerator when the car motor is stopped.

VENTILATION

The installation shall be made in such a manner as to separate the combustion system from the living space of the mobile home or recreational vehicle. Openings for air supply or for venting of combustion products shall have a minimum dimension of not less than 1/4 inch.

Proper installation requires one lower fresh air intake and one upper exhaust vent. The ventilation kits shown in this instruction booklet have been certified for use with the refrigerator models listed in the tables. The ventilation kits must be installed and used without modification. An opening towards the outside at floor level in the refrigerator compartment must be provided for ventilation of heavier-than-air fuel gases. The lower vent of the recommended kits is provided with proper size openings.

For ready serviceability of the burner and control manifold parts of the refrigerator the lower side vent is fitted with a lift-out panel which provides an adequate access opening.

GAS CONNECTION

Hook-up to the gas supply line is accomplished at the manual gas valve, which is furnished with a 3/8" SAE (UNF 5/8" - 18) male flare connection. All completed connections should be checked for leaks with soapy water.

The gas supply system must incorporate a pressure regulator to maintain a supply pressure of not more than 11 inches water gage.

ELECTRICAL CONNECTION

110 Volts A.C.

The refrigerator is equipped with a three prong (grounded) plug for protection against shock hazards and should

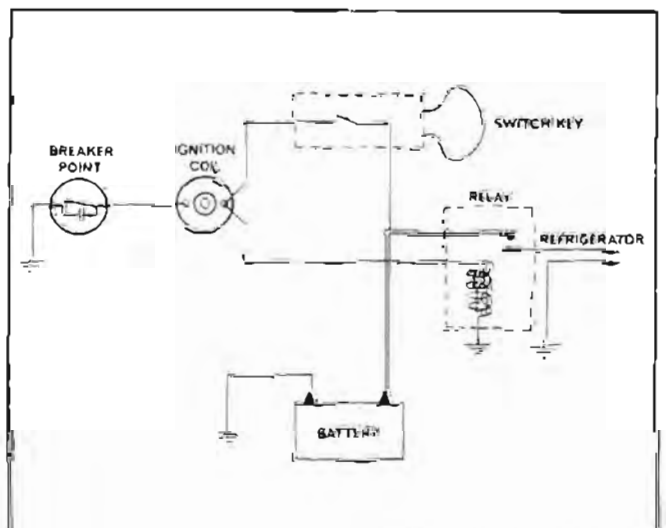

Fig. 7

SPECIAL HINTS

The refrigerator must be installed in a substantial enclosure and must be level. A spirit level is supplied with each refrigerator and by placing it in the freezer compartment, one can level the refrigerator both ways front to back and side to side. When installing the refrigerator in the enclosure, care should be taken to ensure a complete sealing between the front frame of the refrigerator and the top, sides and bottom of the enclosure. For this purpose a length of sealing strip is delivered with each refrigerator.

The strips should be applied to the rear surfaces of the front frame of the refrigerator and to the foremost bottom surface of the enclosure as shown in Fig 8

Be careful not to damage the sealing strip applied to the bottom of the enclosure when the refrigerator is put in place.

Any space between counter or storage area and the top of the refrigerator must be blocked. The heat produced at the rear of the refrigerator will otherwise become trapped in this space making the top of the refrigerator hot and reducing the efficiency of the refrigerator.

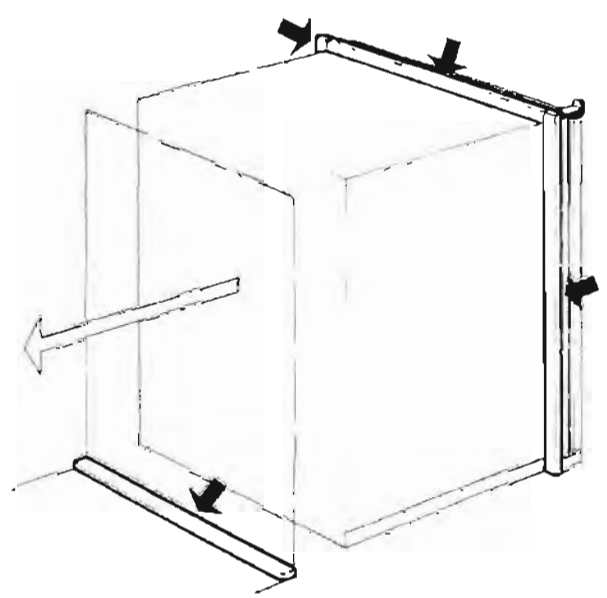

Fig. 8

CERTIFIED INSTALLATION

Certified installations require one roof vent and one lower side vent or as optional one upper vent and one lower side vent.

The two alternatives are provided for by using the different kits listed in the Appendix.

For further information contact your dealer or distributor.

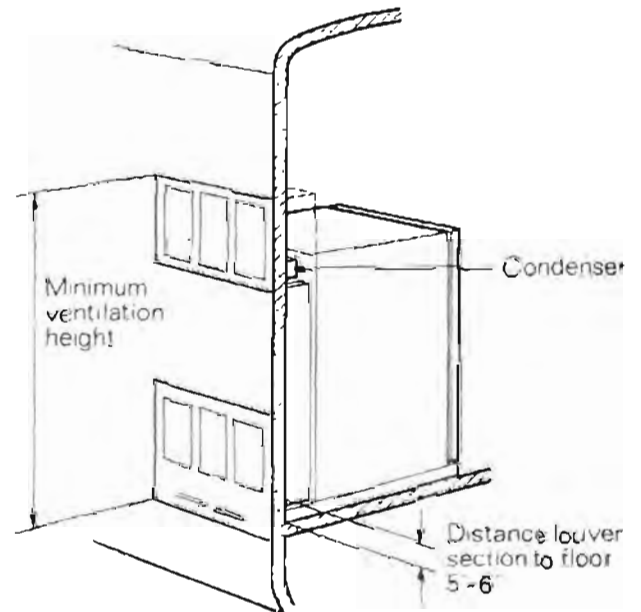

Fig. 9

METHODS OF INSTALLATION

The methods of installation are shown in the figures 9 and 10.

It is essential that all maximum or minimum dimensions are strictly maintained as the performance of the refrigerator is dependent on an adequate flow of air over the rear of the refrigerator.

VENTILATION HEIGHTS

Refrigerator	Minimum ventilation heights in inches	
	Installation with upper and lower side vent	Installation with roof vent and lower side vent
IM-3	37	29
IM-4	-	32
IM-6	-	40
IM-7	-	59

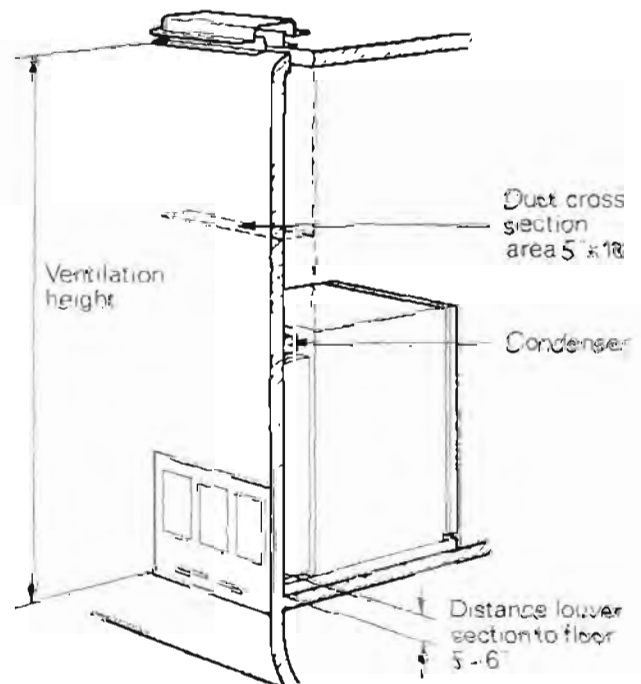

Fig. 10

CLEARANCES

Minimum clearances in inches to combustible materials are

G: Top 0

K: Side 0

L: Bottom 0

M 1

Clearance M between the rearmost part of the refrigerator and the wall behind the refrigerator

Clearance N on top of the condenser is related to the minimum ventilation height

See Fig. 11 and examples below

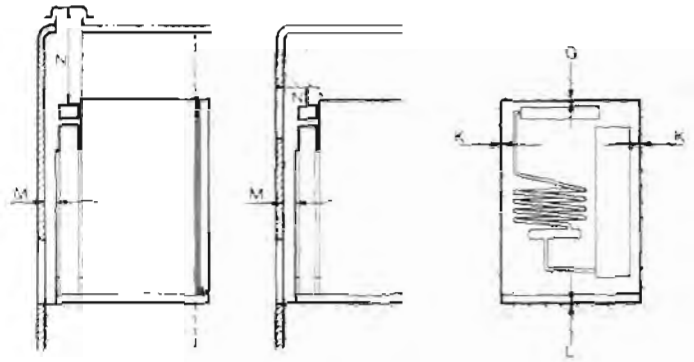

Fig. 11

DIMENSIONS See Fig 12.

Refrigerator model	Overall dimensions			Installation dimensions			Recess dimensions			Distance between top of condenser to top of refrigerator e
	Height A	Width B	Depth C	Height h	Width w	Depth d	Height H	Width W	Depth D	
IM-3	28 13/16	21 7/16	21 7/8	28 3/8	20 1/4	19 5/8	28 3/4	20 1/2	20 5/8	1 1/4
IM-4	31 3/8	22 13/16	24 7/8	30 15/16	21 9/16	22 9/16	31 1/4	21 7/8	23 5/8	1 1/4
IM-6	39 5/16	22 13/16	24 7/8	38 13/16	21 9/16	22 9/16	39 3/16	21 7/8	23 5/8	1 1/4
IM-7	57	24 11/16	24 5/8	56 1/2	23 7/16	22 5/16	56 7/8	23 13/16	23 3/8	1/4

EXAMPLES

The clearance N for the IM-3 model is derived at in the following way:

A. Installation with upper and lower side vents.

$N =$ Minimum ventilation height 37
 minus installation height 28 3/8
 plus distance between condenser top and refrigerator top 1 1/4

$$N = 37 - 28 \frac{3}{8} + 1 \frac{1}{4} = 9 \frac{7}{8}$$

B. Installation with roof vent and lower side vent.

$N =$ Minimum ventilation height 29
 minus installation height 28 3/8
 plus distance between condenser top and refrigerator top 1 1/4
 plus distance between roof surface and roof vent cap 5 1/4

$$N = 29 - 28 \frac{3}{8} + 1 \frac{1}{4} + 5 \frac{1}{4} = 7 \frac{1}{8}$$

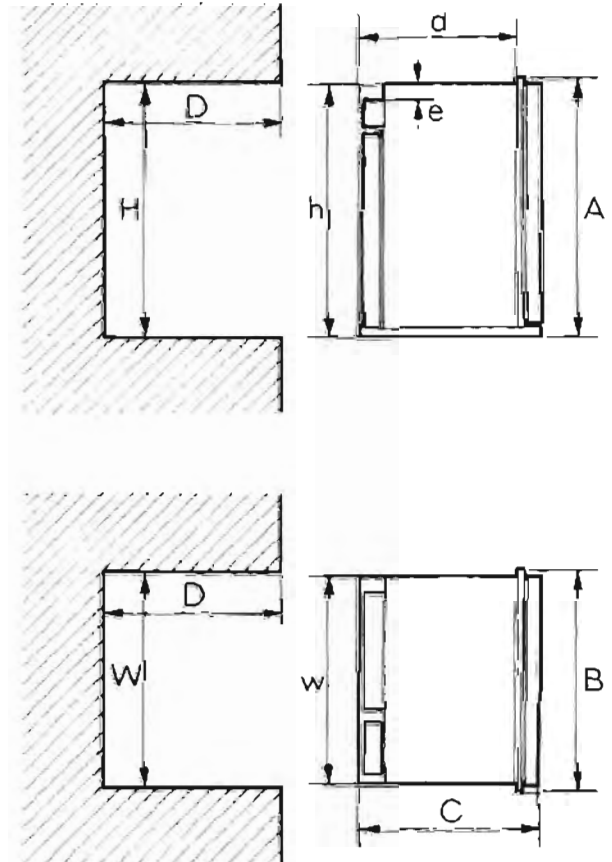
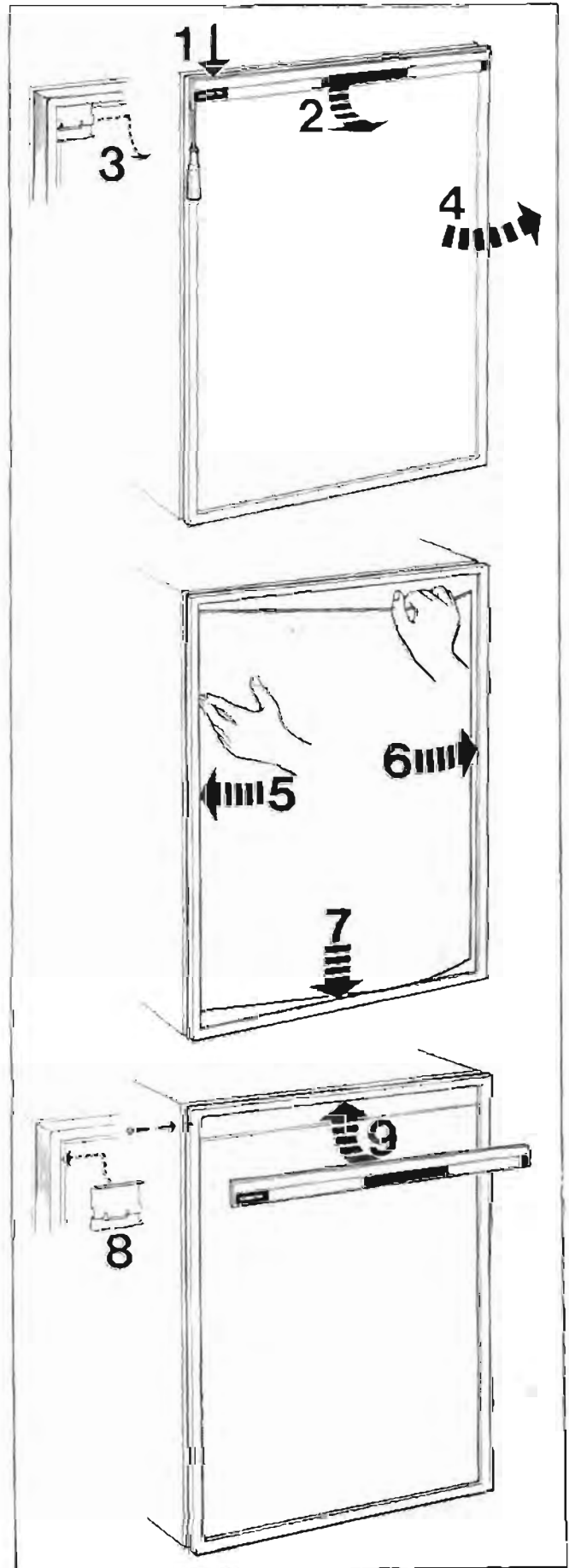

Fig. 12

INSTRUCTIONS FOR MOUNTING THE DOOR PANEL

The refrigerator is normally delivered without door panel(s) and the front of the door is protected by a card board sheet. Before starting the mounting work check that the panel dimensions are in compliance with those given in the table and read the instructions through. When mounting the panel, proceed as follows:

- A. The top decoration strip (2) is removed in the following way:
Push the blade of a screwdriver gently between the door frame and the strip. Push the strip in opposite direction until it snaps out. (1)
Remove the fastening pieces (3) in the frame corners. If a thick panel is to be used, also remove the card board protection (4).
- B. Insert one of the vertical edges of the panel into the groove of the door frame (5).
- C. Bend the panel gently so that the free edge of the panel can be slipped into the corresponding groove of the door frame (6).
- D. Push the panel downwards so that the lower horizontal edge of the panel is fitted into the bottom groove (7).
- E. Between the upper edge of the panel and the door frame there is now a gap which should be covered by the decoration strip.
- F. Put the fastening pieces back into place in the frame corners (8).
- G. Put the strip across the door so that the gap is covered and push it upwards (9).
The tabs on the inside of the strip should fit in behind the flange of the door frame and in the openings in the fastening pieces.



Panel dimensions Thickness max. 5/32"

TYPE	HEIGHT		WIDTH	
	MAX.	MIN.	MAX.	MIN.
IM-7	39 15/16"	39 13/16"	23 3/8"	23 1/4"
IM-7	10"	9 7/8"	23 3/8"	23 1/4"
IM-6	34 29/32"	34 25/32"	21 1/2"	21 3/8"
IM-4	27 1/32"	26 29/32"	21 1/2"	21 3/8"
IM-3	24 15/32"	24 11/32"	20 5/32"	20 1/32"

Storage Volumes

Refrigerator model	Total storage volume in cu.ft.
IM-3	2.9
IM-4	3.7
IM-6	5.0
IM-7	6.4