

SERVICE TIPS

Dometic **REFRIGERATORS**

Models

RM2612	RM2812
RM2652	RM2852

THE MOST COMMON SYSTEM PROBLEMS ASSOCIATED WITH THE RM2612, RM2812, RM2652, RM2852 REFRIGERATORS

SYMPTOM

CAUSE

REFRIGERATOR SECTION

- | | |
|---|--|
| 1. No operation - no panel lights | Operation
DC Volts
Fuse
Wiring
Upper Circuit Board
Lower Circuit Board |
| 2. No operation - has panel lights | Operation
DC Volts
Thermistor
Fuses
Wiring
Lower Circuit Board |
| 3. No AC operation - operates on gas mode | Operation
AC Volts
Fuse
Heating Element
Wiring
Lower Circuit Board |
| 4. No Gas operation - operates on AC mode | Operation
LP Gas
Manual Gas Valve
Igniter
High Voltage Cable
Electrode
Solenoid
Wiring
Lower Circuit Board |
| 5. Insufficient cooling on all modes. | Ventilation
Leveling
Ambient Temperature
Air Leaks
Thermistor
Cooling Unit |
| 6. Insufficient cooling on AC - cools properly on gas mode. | AC Volts
Heating Element
Lower Circuit Board |

SYMPTOM

7. Insufficient cooling on Gas - cools properly on AC mode.
8. Freezes.
9. Check light on.
10. Interior light on when door is closed.
11. Rapid formation of frost.
12. Water on frame.

CAUSE

- LP Gas
- Orifice
- Flue Baffle
- Flue Tube
- Burner
- Lower Circuit Board

- Operation
- Thermistor
- Lower Circuit Board

- DC Volts
- Wiring
- LP Gas
- Manual Gas Valve
- Solenoid
- Orifice
- Burner
- Thermocouple
- Lower circuit Board

- Wiring
- Door Switch
- Door Position

- Food Storage
- Interior Liner to Frame
- High Humidity
- Air Leaks

- Interior Liner to Frame
- High Humidity
- Air Leaks
- Climate Control Heater

REFRIGERATOR OPERATION

DISPLAY PANEL (RM2652, RM2852)

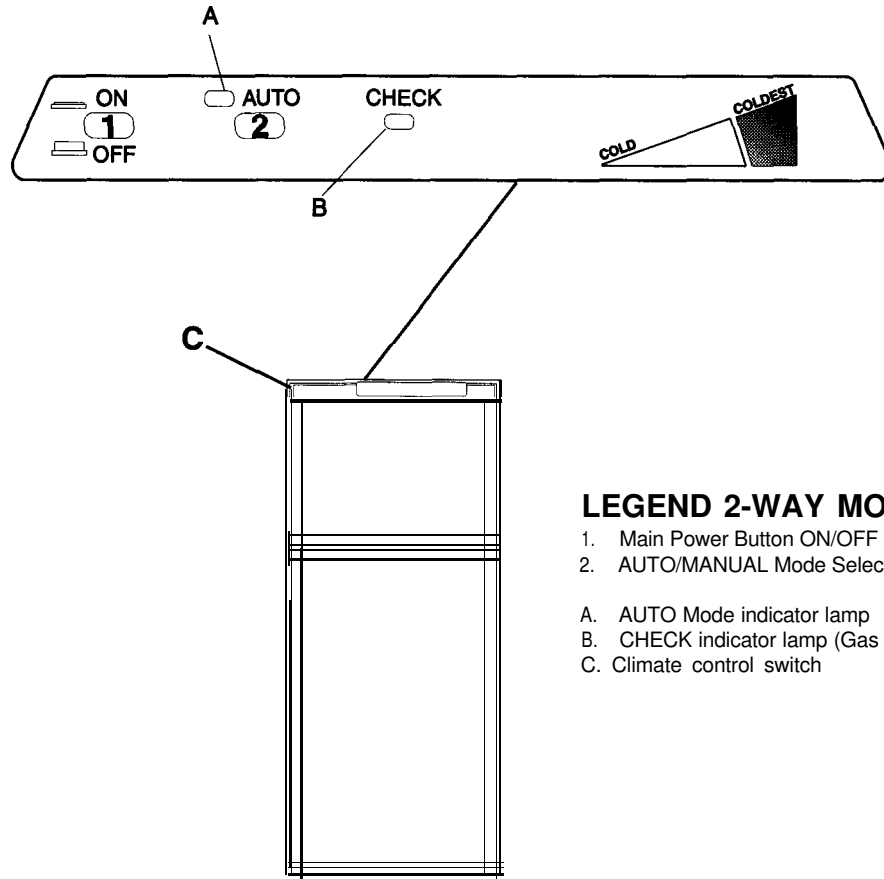

LEGEND 2-WAY MODEL

- 1. Main Power Button ON/OFF
- 2. AUTO/MANUAL Mode Selector Button
- A. AUTO Mode indicator lamp
- B. CHECK indicator lamp (Gas Mode Only)
- C. Climate control switch

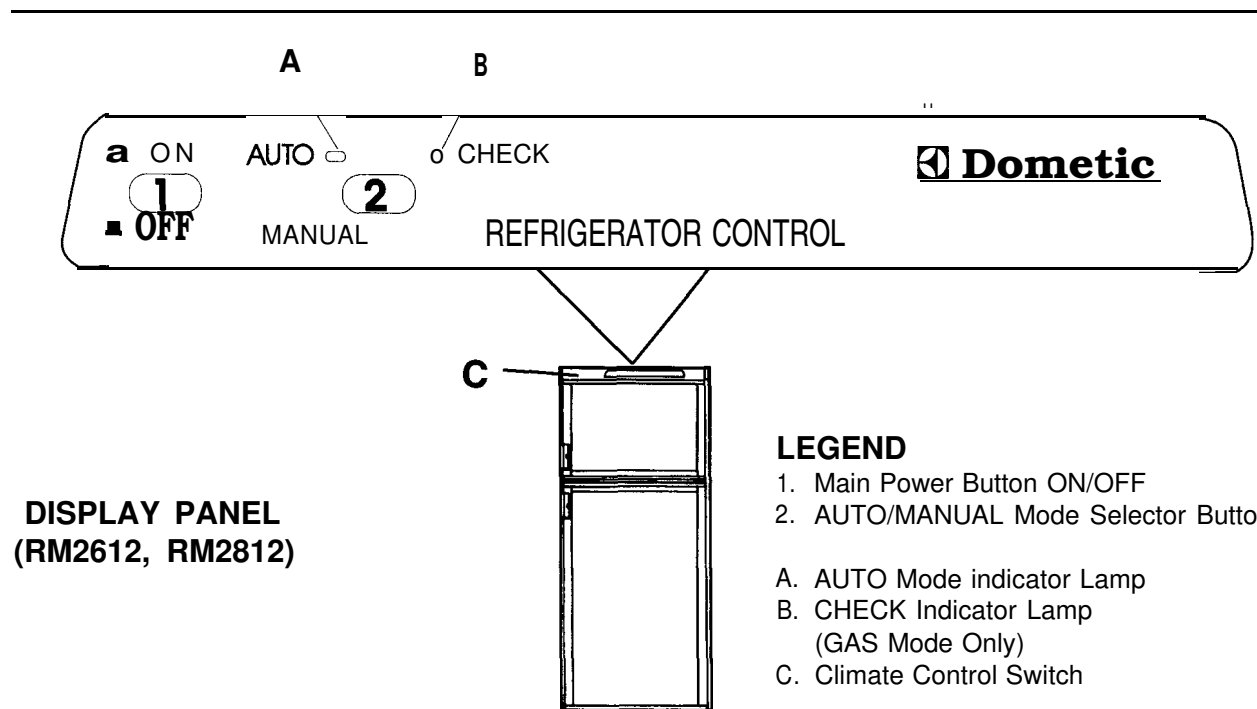

DISPLAY PANEL (RM2612, RM2812)

LEGEND

- 1. Main Power Button ON/OFF
- 2. AUTO/MANUAL Mode Selector Button
- A. AUTO Mode indicator Lamp
- B. CHECK Indicator Lamp (GAS Mode Only)
- C. Climate Control Switch

START-UP INSTRUCTIONS

Before starting the refrigerator, check that all the manual gas valves are in the ON position. DO NOT forget the manual shutoff valve on the rear of the refrigerator.

This refrigerator is equipped with a control system, which can automatically select the most suitable energy source which is available, either 120 Volt AC or LP gas operation. The refrigerator can be operated in either the AUTO mode (thermostat factory preset below the safe food storage temperature) or MANUAL mode (continuous operation - no thermostat control).

NOTE: Under certain cool weather conditions, the food in the lower portion of the fresh food compartment may freeze if operated for an extended period of time on the MANUAL mode.

- A. A 12 volt DC supply must be available for the electronic control to function. The refrigerator will work down to 9.6 volt DC.
- B. Press the main power ON/OFF button (1) to the DOWN position.
- B. In AUTO mode operation, the temperature is controlled by a single temperature setting, on the energy source selected by the control system. (See Auto Mode)
- C. In MANUAL mode operation, the refrigerator will run continuously on the energy source selected by the control system. (See Manual Mode)

NOTE: The food in the lower compartment may be frozen if the refrigerator is left on MANUAL mode.

TO SHUT OFF THE REFRIGERATOR

The refrigerator may be shut off while in any mode of operation by pressing the main power ON/OFF button to the UP (OFF) position. This shuts off all DC power to the refrigerator, including the interior light.

OPERATING MODES

AUTO MODE

Press the AUTO/MANUAL mode selector button (2) to the DOWN position. The AUTO mode indicator lamp (A) will illuminate.

When operating in the AUTO mode, the AUTO mode indicator lamp (A) will illuminate. The control system will automatically select between AC and GAS operation with AC having priority over GAS. If the control system is operating on AC energy and it then becomes unavailable, the system will automatically switch to GAS. As soon as AC becomes available again the control will switch back to AC operation.

If 120 volts AC is not available, the control system will automatically switch to GAS operation. Within 45 seconds the burner should be ignited and operating normally. If unsuccessful, the CHECK indicator lamp (B) will illuminate.

To restart an ignition attempt with the CHECK lamp illuminated or to clear (turn off) the CHECK lamp, press the main power ON/OFF button to the OFF and then to the ON position. The control system will attempt a new 45 second ignition sequence.

On the initial refrigerator start-up on gas (120 volts AC is not available), it may take longer than 45 seconds to allow air to be purged from the gas line. If the refrigerator has not been used for a long time or the LP tanks have just been refilled, air may be trapped in the supply lines. To purge the air from the lines may require resetting the main power ON/OFF button (1) three or four times. If repeated attempts fail to start the LP gas operation, check to make sure that the LP gas supply tanks are not empty and all manual shutoff valves in the lines are open.

NOTE: DO NOT continue to reset GAS operation if the CHECK indicator lamp continues to be illuminated after 3 or 4 tries.

If 120 volts AC becomes available while the CHECK indicator lamp is on, the control system will switch to 120 volt AC operation, The CHECK lamp will not turn off until the main power ON/OFF button is pressed to the OFF then ON position.

In AUTO mode operation, the temperature is controlled by a single temperature setting.

MANUAL MODE

When operating in the MANUAL mode, the AUTO mode indicator lamp (A) will be off, and the refrigerator will run continuously on the energy source selected by the control system.

NOTE: The food in the lower compartment may be frozen if the refrigerator is left on "MANUAL" mode.

STANDBY MODE

This control system contains a feature that will continue to operate the cooling system in the event of a failure of a major operating component. If the control cannot read the temperature sensor and operate at the preset temperature, then the control will run the cooling unit like the MANUAL mode.

The refrigerator will continue to operate in this mode indefinitely or until a new sensor is installed and the system is reset.

AC VOLTAGE REQUIREMENTS

The proper operating range is 100 to 132 volts. If voltage drops below 100 volts, cooling efficiency will decrease with voltage decrease. The refrigerator will not switch to another mode of operation until all **AC power is lost**.

The refrigerator is equipped with a three-prong (grounded) plug for protection against shock hazards, and should be plugged directly into a properly grounded three-prong receptacle.

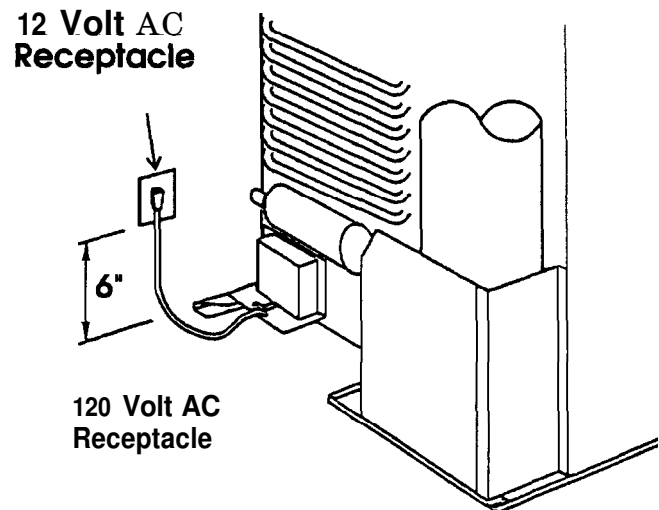

COMPONENTS- HEATING ELEMENT

Remove the heater leads from the lower circuit board and measure for proper resistance across the two leads.

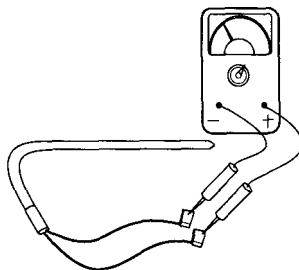

You should obtain the following readings, $\pm 10\%$:

	WATTS	VOLTS	OHMS
RM2612	295	120	48
RM2652	325	120	44
RM2812	325	120	44
RM2852	325	120	44

DC VOLTAGE REQUIREMENTS

Clean Direct Current (DC) power is mandatory for high-tech circuits to operate as designed.

A battery will provide straight line DC power.

The converter and alternator produce DC power by a series of diodes that rectify alternating current to DC.

AC ripple can be measured by a digital voltmeter set on the AC scale at the main terminal block connections. Six volts AC or less is acceptable.

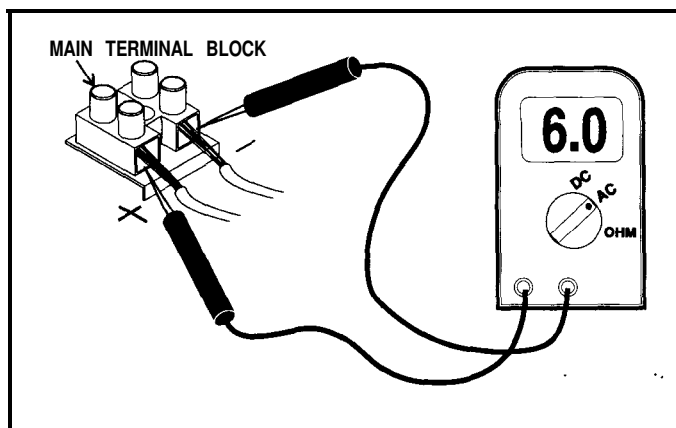

The operational range of the unit is a minimum of 9.6V DC to a maximum of 22V DC. At 22V DC, the unit will automatically shut down until voltage has decreased to 18V DC for proper operation; however, the panel lights will continue to illuminate until voltage has dropped to 4V DC or below.

Do not use the body or chassis of the RV as a substitute for either or the two conductors. Proper polarity is crucial for refrigerator operation.

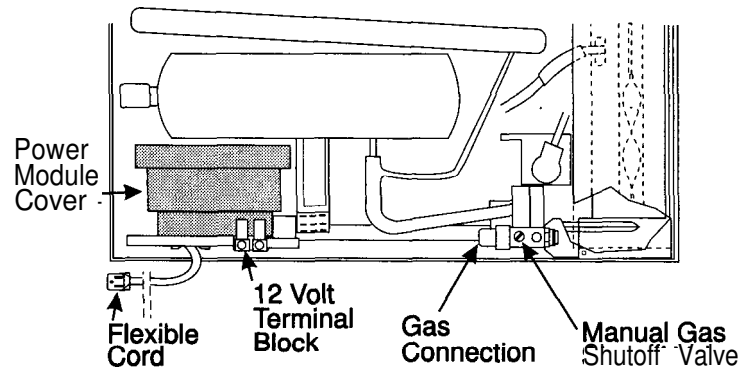
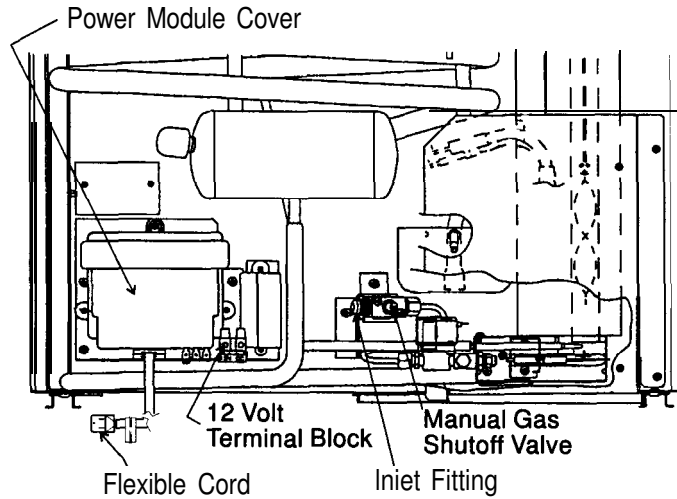

DC COMPONENTS

THERMISTOR

Disconnect the thermistor harness from the P2, 2-pin terminal on the lower circuit board. Place the thermistor in a glass of ice water, approximately 33°F to 35°F. Wait 2 to 3 minutes. You should get a reading of approximately 7,000 to 10,000 ohms.

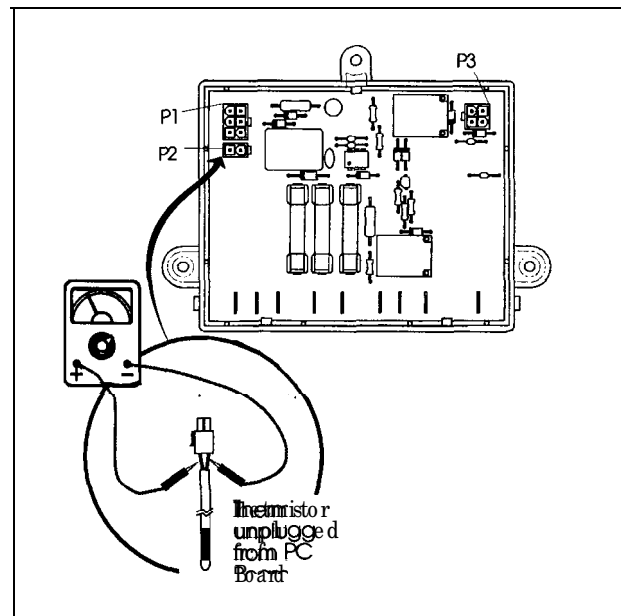

SOLENOID VALVE

Check the solenoid coil with a properly calibrated ohm meter. Remove the connector from the solenoid and measure the resistance across the terminals. The proper reading would be 49 ohms with tolerance range of ten percent.

Next, hook up a manometer at the test port. Then check for DC volts at gas valve terminals while the unit is in trial-for-ianition. If DC volts are present and pressure is low, replace the valve. If DC volts are not present at the valve while the unit is in trial-for-ianition, verify that the wire at Plug 3, Terminal 2 on lower circuit board have DC volts (9 or more).

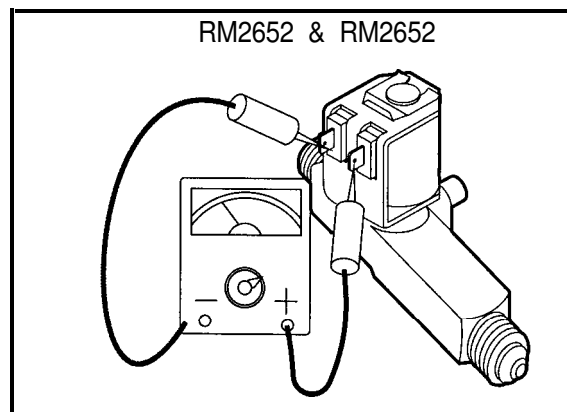
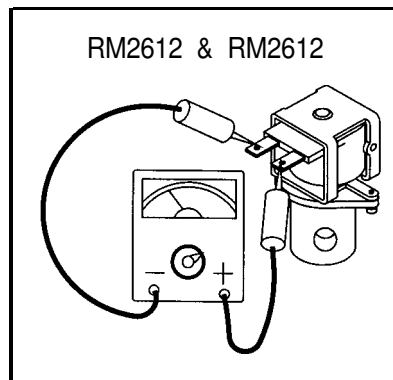

IGNITER

First verify proper voltage at the positive (+) and ground (-) terminals of the igniter. The reading should be within one volt of incoming voltage at the main terminal block during trial-for-ianition.

Next, remove high voltage cable from igniter. The igniter should produce a sparking sound, during trial-for-ianition. If not, replace the igniter.

The igniter installed on the refrigerators as original equipment is part number 2931132019 (RV Gas Model 679). This igniter is rated 50 MA. This igniter may also be used on any other model.

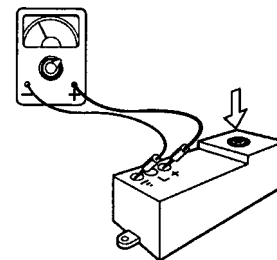

DO NOT install the Channel Mark 6, Model 12E igniter (shown below) as a service replacement part.

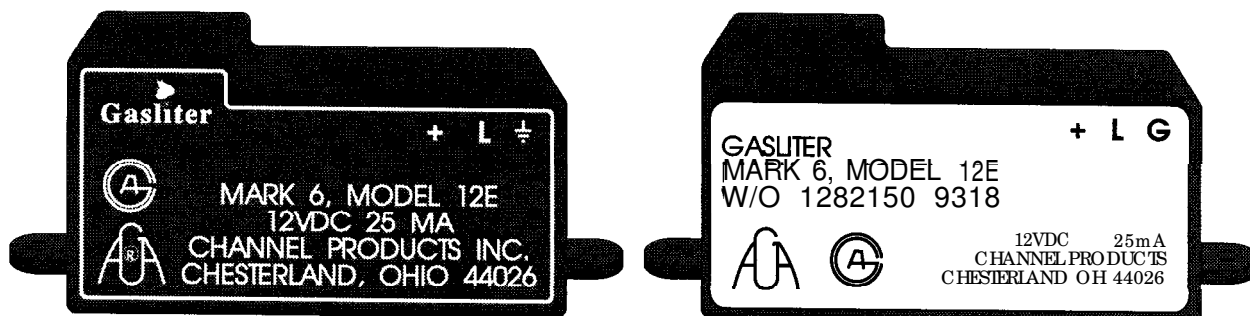

Installation of the Channel Products, Inc., Gasliter Mark 6, Model 12E, will VOID the Warranty on the refrigerator.

HIGH VOLTAGE CABLE

Disconnect high voltage cable from electrode. If sparking starts during trial-for-ianition, the cable is good. If there is no sparking during trial-for-ianition disconnect high voltage cable at the igniter. If there is a sparking sound from the igniter during trial-for-ianition, then replace high voltage cable.

ELECTRODE

Do a visual check for cracks or breaks on the ceramic insulator. The spark gap must be set at three sixteenths ($3/16''$) of an inch and tip of electrode above the slots in the burner.

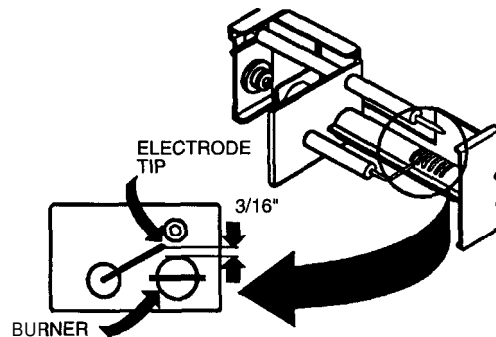

UPPER CIRCUIT BOARD

NOTE: The PAL tester will allow for proper testing of the integrity of the upper and lower circuit boards. PAL is available from your Dometic parts distributor.

With main ON/OFF switch on display panel **in OFF** position:

Check for DC voltage at Plug 1, Terminal 4 (orange wire) and terminal 5 (red wire) negative (-) DC on the **lower circuit board**. If no voltage, then check fuse condition. Check for DC voltage between J4 and J10 terminals on the lower circuit board.

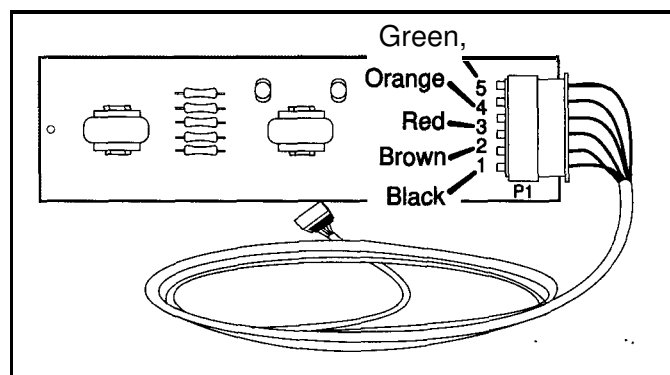

Next, check for DC voltage at the upper circuit board between terminal 4 (orange wire) and terminal 3 (red wire) which is negative (-) DC. If no voltage, and your previous check proved voltage at the lower circuit board between these wires, replace the cable assembly.

With main ON/OFF switch on display panel in ON position:

Check for DC volts between terminal 3, red wire (-) negative and terminal 5 (green wire) and terminal 1 (black wire). If there is no voltage, the ON/OFF switch on upper circuit board is defective.

Next, do the same voltage test at the lower circuit board. Red wire (-) negative plug 1, terminal 5, to green wire, plug 1, terminal 1 and black wire, plug 1, terminal 3. If there is no voltage and you had voltage on previous test, the cable assembly is defective.

LOWER CIRCUIT BOARD

The controls for Models RM2612, RM2812, RM2652 and RM2852 are unique to these models. They are NOT interchangeable with any other models.

If you suspect mismatched part numbers, compare the part numbers on parts to the ones listed below to ensure a proper match.

The RM2612 with Serial Number 41900000 or higher will have Version III controls as original equipment.

The RM2812, RM2652 and RM2852 should have only Version III controls as original equipment.

VERSION I

Display Panel	2932189.01
Power Module	2931842.02 or 2931842.03
Thermistor	2931863035

VERSION II

Display Panel	2932189.02
Power Module	2931842.02X
Thermistor	2931863035

* Power Module has red plugs and a Red Dot on the cover.

**Power Module
2931842.02X**

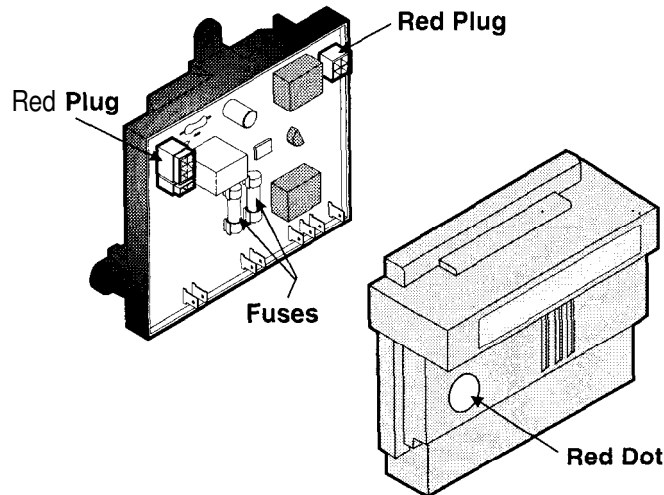

VERSION III

Display Panel	2932189.03
Power Module	2931842.04
Thermistor	2931863035

**Power Module
2931842.04**

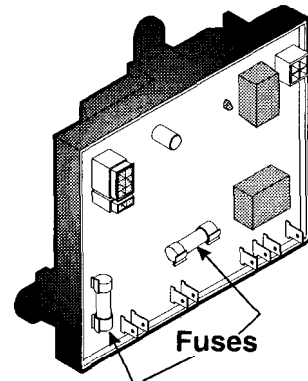

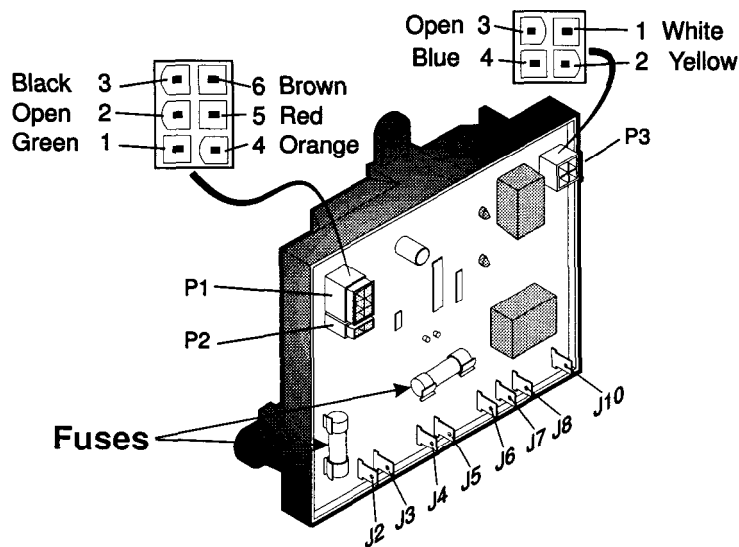

- A. **DC VOLT:** ALL TESTS ARE TO BE DONE WITH THE REFRIGERATOR IN THE COOLING MODE. Measure volts between terminal J4 and the ground strip.
- B. **AC MODE:** Check that incoming AC voltage is present at terminals J5 and J6 on the circuit board. Check for voltage at the heating element connection terminals J7 and J8 on the circuit board. If no voltage is present, check the 5 amp AC and 3 amp DC fuses.
- C. **GAS MODE:** First, check for voltage during trial-for-ignition at Plug 3, Terminals 1 (white wire) and 2 (yellow wire) to the solenoid. If no voltage is present, change the circuit board. If voltage is present, check for voltage at the solenoid.

Check for voltage to the igniter. If no voltage is present, check the wires. If good, then change the circuit board.

If flame extinguishes during the cooling mode, the circuit board will not supply voltage to Plug 3, Terminal 4 (blue wire) until the millivolts have decreased to 10 ± 3 .

To check the flame sense circuit of the lower circuit board, measure the millivolts between J3 terminal and the other wire connection from the thermocouple. The millivolt meter should read between 25 to 35 millivolts with the gas flame burning. Turn the manual shutoff valve to OFF and watch the millivolt reading as it drops. Note the millivolt reading when Plug 3, terminal 4 (blue wire) receives power. It should be 10 ± 3 millivolts or 7 to 13.

DOOR SWITCH (Only on Models Equipped with Interior Lights)

When the switch arm is depressed, there should not be continuity. When the switch arm is NOT depressed, there should be continuity.

FUSES

The 3 amp DC fuse is designed to protect the circuit board from internal shorts. The 5 amp AC fuse is designed to protect the integrity of the AC heater circuit from shorts.

CLIMATE CONTROL HEATER

To check the switch, disconnect the wires and do a continuity check. In the OFF position, there should be no continuity. In the ON position, there should be a continuity reading.

To check the heater itself, do an ohms resistance reading on the heater wire by using a properly calibrated ohm meter. The proper ohms reading is 24 ohms \pm 10%. The approximate amp draw is less than .5 (1/2) amp.

LP GAS REQUIREMENTS

The LP gas pressure to the refrigerator should be 11 inches water column with half of all BTU's of the RV turned on. With all other appliances off, the pressure to the refrigerator should not exceed 12 inches water column. To check the gas pressure when the refrigerator is operating, there is a pressure test port on the solenoid.

RM2612 & RM2812

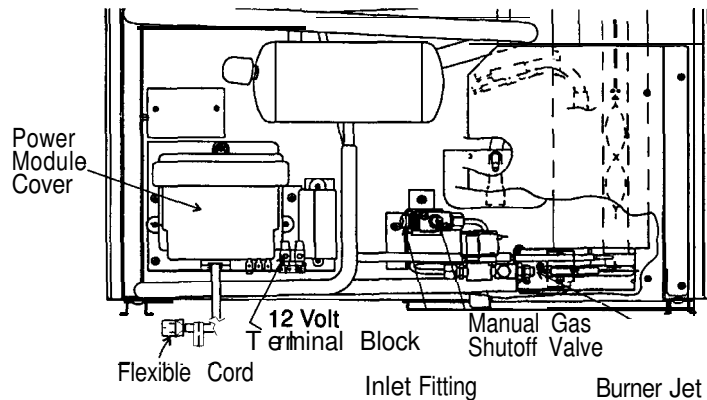

RM2652 & RM2852

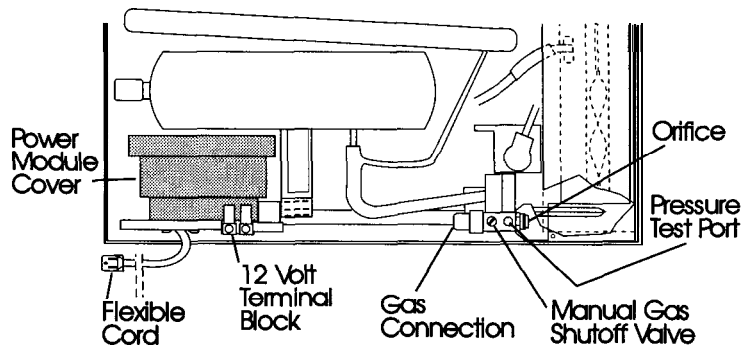

SECTION 7
LP GAS COMPONENTS

MANUAL GAS SHUTOFF VALVE

To check the shutoff valve, remove and inspect for any obstructions.

RM2652 & RM2852

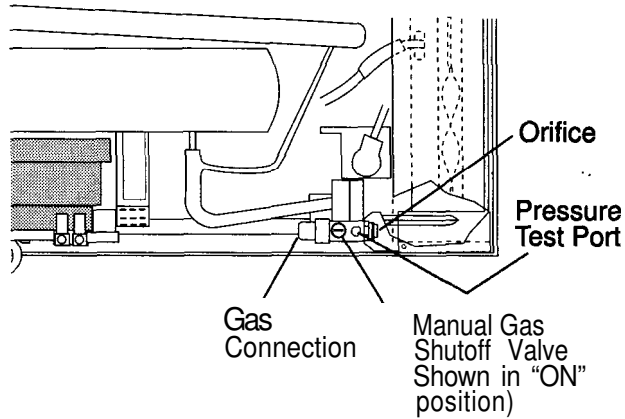

RM2652 & RM2852

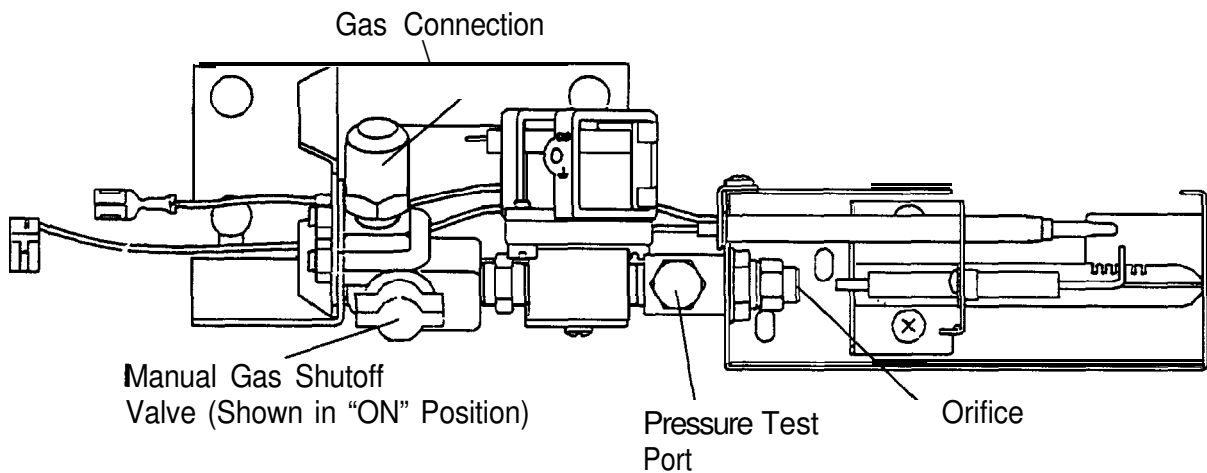

ORIFICE

The orifice is cleaned by using an alcohol based solvent and allowing to air dry.

If there is a lack of cooling on gas operation, verify the orifice is the proper size per the chart below:

RM2612	#53
RM2812	#58
RM2652	#58
RM2852	#58

THERMOCOUPLE

The thermocouple should produce 25 to 35 millivolts when connected to the lower circuit board. Any reading below 18 millivolts could cause erratic gas operation.

BURNER

The burner should be cleaned periodically, at least once a year. Soak the burner in an alcohol-based solvent and allow to air dry.

FLUE BAFFLE

At least once a year, clean and check for any damage.

The proper position of the baffle above the burner should be as follows:

RM2612	1-5/8"
RM2812	1-3/4"
RM2652	1-7/8"
RM2852	1-7/8"

FLUE TUBE

The flue tube must be cleaned periodically. Remove flue cap and flue baffle, then cover the burner and clean by using a flue brush, Dometic Part No. 0151404001,

WIRING

EXTERNAL WIRING

A. 120 volts AC Connection

The refrigerator is equipped with a three-prong (grounded) plug for protection against shock hazards and should be plugged directly into a properly grounded three-prong receptacle.

B. 12 Volt DC Connection

The 12 volt DC supply circuit must be fused, and the maximum fuse size is 5 amps.

DO NOT use the chassis or vehicle frame as one of the conductors,

Clean Direct Current (DC) power is mandatory for high-tech circuits to operate as designed.

A battery will provide straight line DC power.

The converter and alternator produces DC power by a series of diodes that rectify alternating current to DC.

INTERNAL WIRING

Verify the refrigerator is wired per the wiring diagram for the **exact** model you are working on. See the following typical wiring diagram.

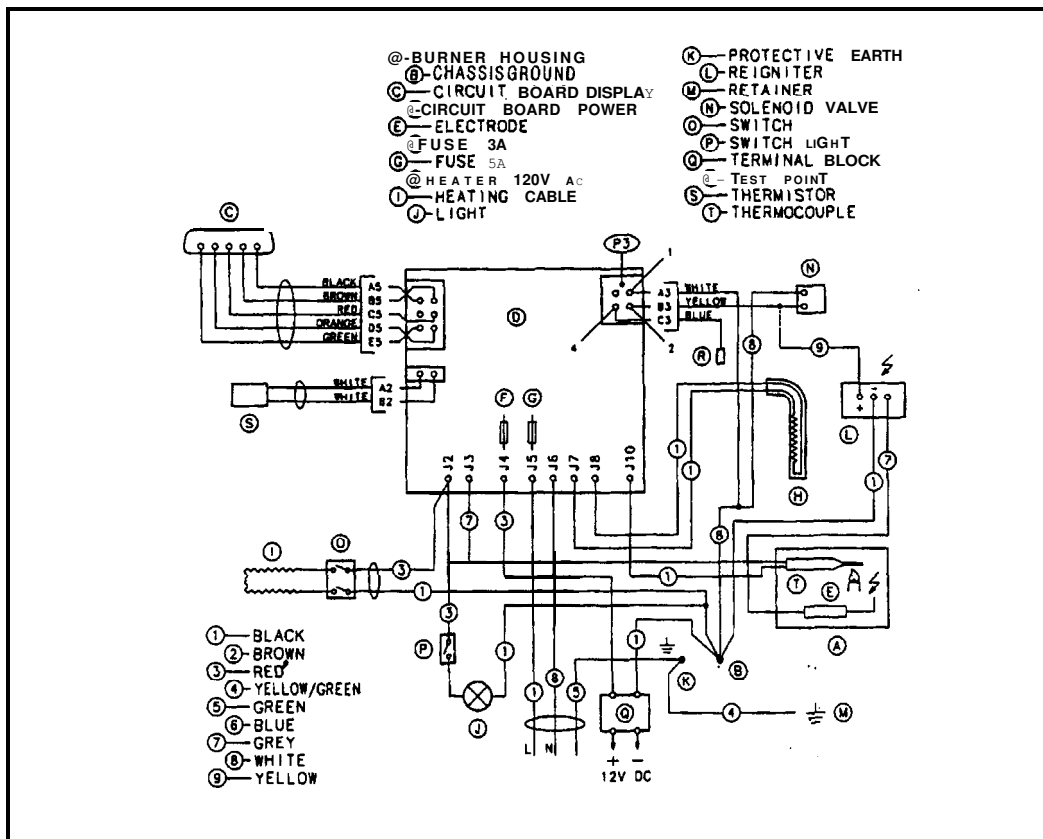

OTHER

LEVELING

The absorption design utilizes no mechanical pumps or compressors to circulate the refrigerant within the system, so proper leveling must be maintained to provide the correct refrigerant flow. Without proper leveling refrigerant within the cooling unit will collect and stagnate at certain areas. Refrigerators have a type of cooling unit that utilizes an enclosed pump tube. To ensure proper leveling, the vehicle needs to be leveled so it is **comfortable to live in**. When the vehicle is moving, leveling is not critical as the rolling and pitching movement of the vehicle will pass to either side of level, keeping the refrigerant from accumulating in the piping.

VENTILATION

The coach vent system must be able to provide a way to direct the hot air produced by the action of the cooling unit, out away from the installation of the refrigerator. There should be as little open space as possible surrounding the sides and top of the refrigerator to achieve proper air flow.

NOTE: Refrigerators should be installed in accordance with appropriate installation instructions received with the refrigerator.

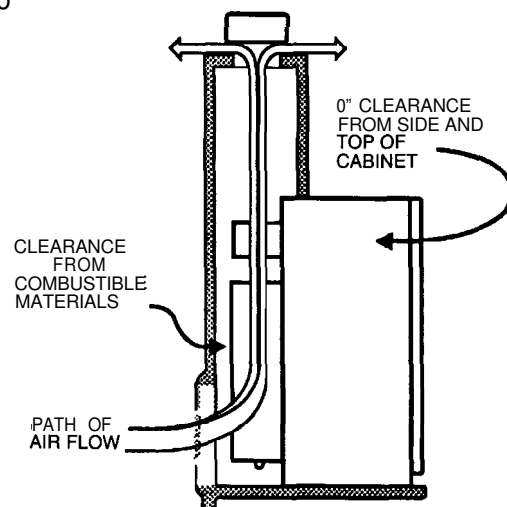

AIR LEAKS

Check the gasket on the doors to be sure of a positive air seal. Close the door on a dollar bill, then pull the dollar bill out. If a gasket is not sealing properly, warm the gasket material with a hair drier.

Close the door and the magnetic strip should pull the gasket to the metal frame. Check that the cooling unit is installed properly.

MODELS RM2612 & RM2812:

The refrigerator is secured in the enclosure with six screws and they must be installed in the following order:

- First Two Screws** installed on front base;
- Second Two Screws** installed in the top frame;
- Third Two Screws** installed in the rear base.

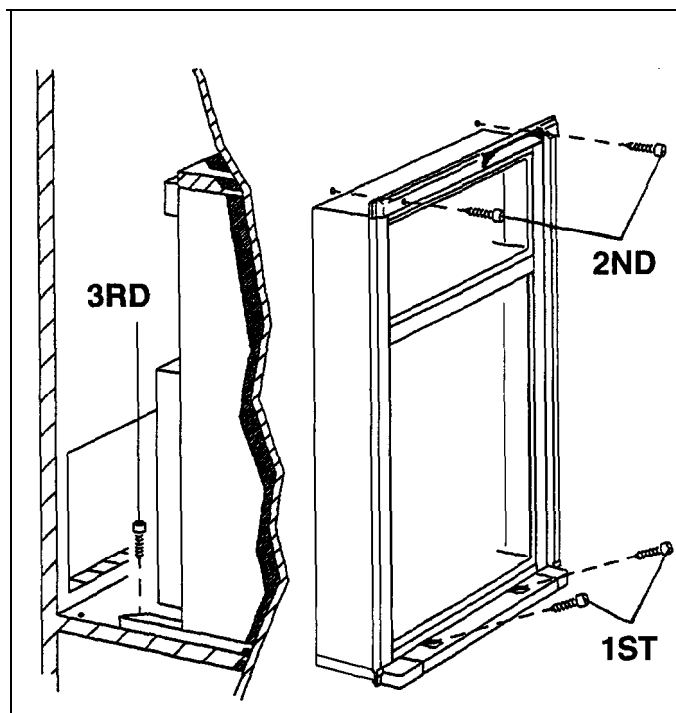

MODELS RM2652 & RM2852:

CONDENSATE WATER DRAIN HOSE: A 3/4" hole must be drilled through the flooring in the opening of the base plate on the rear of refrigerator. Seal around the hose where it goes through the hole.

The refrigerator is secured in the enclosure with six screws. They must be installed in the following order:

First: **Two screws are installed in front decoration strip and through the front base.**

- A. The front strip is to be installed after the refrigerator is set into the alcove.
- B. Install the lower front strip by sliding it under the bottom hinge plate as shown.

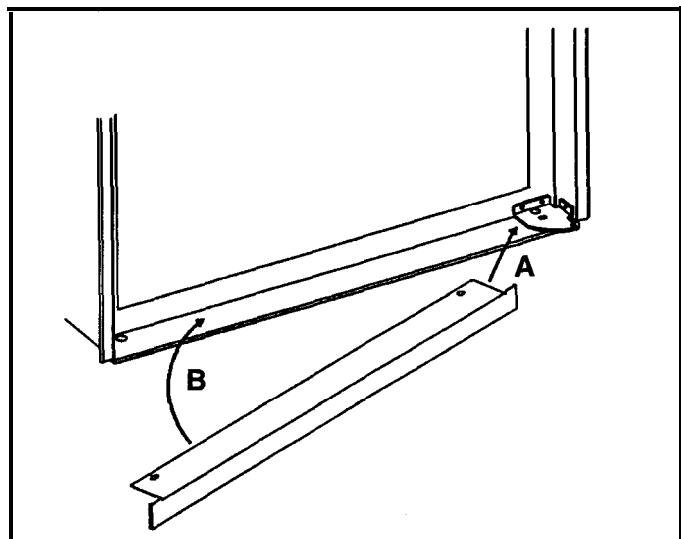

C. When the front strip is in place, install one screw through the hinge and into the floor. The second screw is installed with a washer on the opposite side.

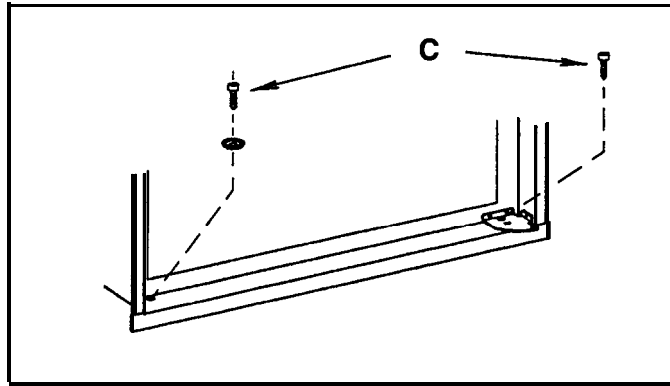

Second: Install the two screws in the top frame.

A. The top decoration panel must be removed from the refrigerator before the screws can be installed. Open refrigerator door and gently push the tabs out of the hole in the hinge with flat blade screwdriver.

B. Carefully tilt the top decoration panel and lift up to remove from top frame.

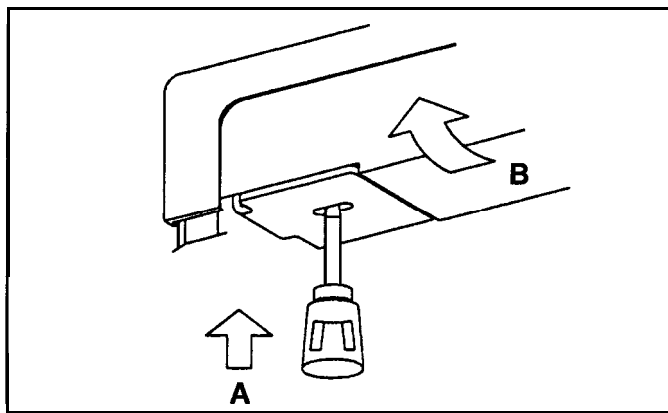

C. Install the second two screws in the top frame as shown.

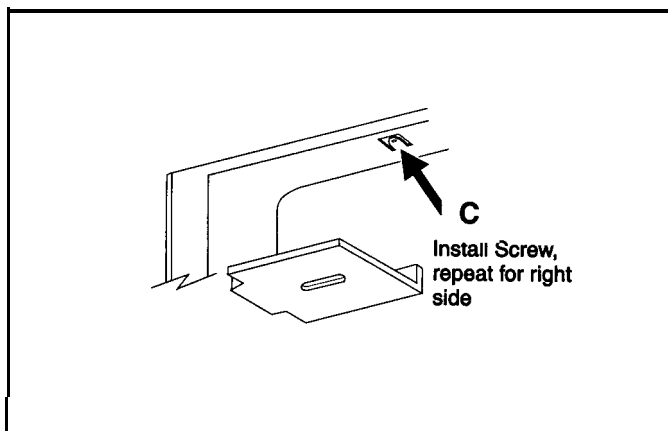

D. Replace the top **decoration panel**.

Third: Two screws installed as shown in rear base.

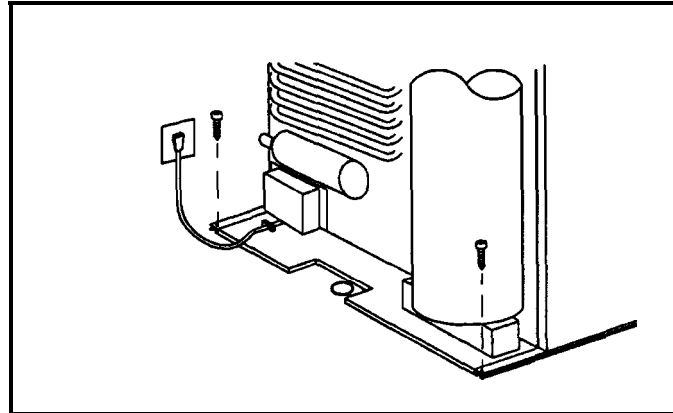

DOOR POSITION

The door position can be checked by observing any misalignment of the door in relation to the frame.

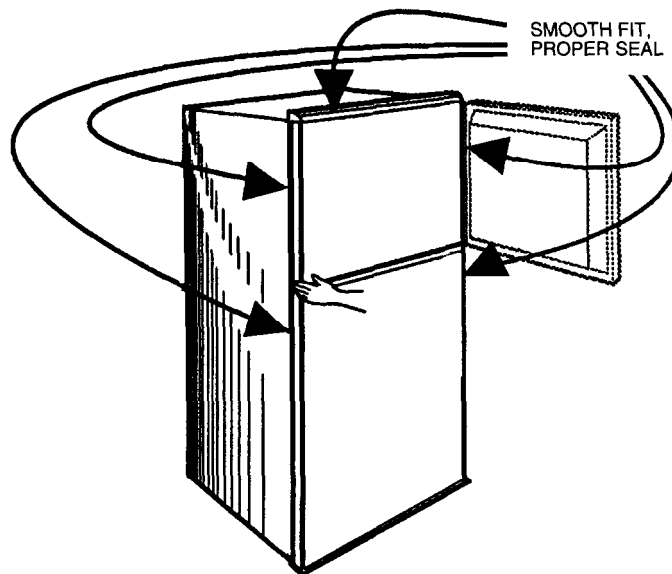

Loosen the hinge bracket screws, reposition the door then tighten the hinge bracket screws.

To adjust up or down, add or remove washers from the lower hinge pin.

AMBIENT TEMPERATURE

As the ambient temperature increases, the air temperature in the area of the cooling unit increases. The double door refrigerators should maintain approximately 43 degrees food storage temperature at 110 degree ambient temperature.

COOLING UNIT

The cooling unit is a self-contained, hermetically sealed set of coils where the refrigeration process takes place. The chemicals involved in the cooling process include hydrogen, ammonia, water and a rust inhibiting agent. There are no repairs recommended on the cooling unit.

To check the cooling unit, first verify the AC heating element is good. Then place approximately one gallon of water inside the refrigerator and place a thermometer in one of the containers of water. Supply 115 volts direct to the AC heating element and operate for at least 12 hours. Check the temperature on the thermometer. It should be at 45 degrees or lower depending on test conditions.

FOOD STORAGE

It is essential that the shelves are not covered with paper or large storage containers.

Odorous or highly flavored foods should always be stored in covered dishes, plastic bags or wrapped in foil or waxed paper to prevent food odors. Vegetables, lettuce, etc., should be covered to retain their crispness. **NEVER PUT HOT FOOD INTO THE REFRIGERATOR.**

HIGH HUMIDITY

Condensation may actually run off the frame. As the humidity is reduced, the "sweating" will decrease. High humidity can also be a factor in rapid formation of frost.

INTERIOR LINER SEAL TO FRAME

Condensation could form on the frame. Apply a small bead of silicone all the way around the perimeter where the frame meets the interior liner.

Slide the refrigerator out approximately 2-4 inches. Apply a foil-backed adhesive tape to the joint between outer frame and foil-backed refrigerator insulation.

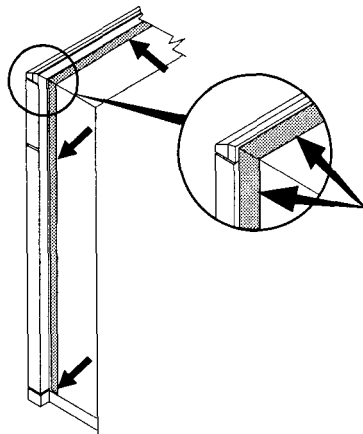

Use a clear silicon caulking compound and seal the seam between the refrigerator's plastic liner and the metal frame.

NOTE: TO FORM A PROPER SEAL, IT IS IMPORTANT NOT TO LEAVE ANY GAPS.

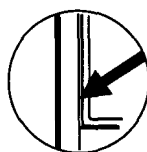

CAULK SEAM BETWEEN PLASTIC LINER AND METAL FRAME

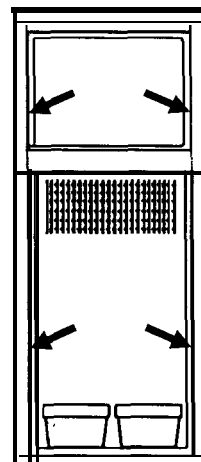

(Refrigerator shown with doors removed)