

hydro flame

SERVICE & PARTS MANUAL



EFFECTIVE JANUARY 15, 1985

INDEX

GENERAL SERVICE INFORMATION	Page
a. Direct Spark Ignition (DSI) Models	2, 3, 4
b. Pilot Ignition Models	5, 6, 7, 8
c. Vent information	8
72 SERIES INFORMATION	
a. Schematic Drawing	9
b. Parts Price List for (DSI and Pilot) Models	10
c. Flat Rate Labor Schedule (DSI) Models	11
d. Flat Rate Labor Schedule (Pilot) Models	12
e. Service Information on (DSI) Models	13, 14
f. Service Information on (Pilot) Models	15, 16
g. FA-72 Series Wiring Diagram for (DSI) Models	17
h. FA-72 Series Wiring Diagram for (Pilot) Models	17
76 SERIES INFORMATION	
a. Schematic Drawing	18
b. Parts Price List for (DSI) Models	19
c. Flat Rate Labor Schedule (DSI) Models	20
d. Electrical Connection and Burner Adjustment	21
e. FA-76 Series Wiring Diagram for (DSI) Models	21
77 SERIES INFORMATION	
a. Schematic Drawing	22
b. Parts Price List for (DSI and Pilot) Models	23
c. Flat Rate Labor Schedule (DSI) Models	24
d. Flat Rate Labor Schedule (Pilot) Models	25
e. Electrical Connection and Burner Adjustment and Air Box Adjustment	26
f. HF-77 Series Wiring Diagram for (DSI) Models	27
g. HF-77 Series Wiring Diagram for (Pilot) Models	27
79/80 SERIES INFORMATION	
a. Schematic Drawing	28
b. Parts Price List for (DSI and Pilot) Models	29, 30
c. Flat Rate Labor Schedule (DSI) Models	31
d. Flat Rate Labor Schedule (Pilot) Models	31
e. Electrical Connection and Burner Adjustment	32
f. FA-79 Series Wiring Diagram for (DSI) Models	33
g. FA-79 Series Wiring Diagram for (Pilot) Models	33
78/82 SERIES INFORMATION	
a. Schematic Drawing	34
b. Parts Price List for (DSI and Pilot) Models	35, 36
c. Flat Rate Labor Schedule (DSI and Pilot) Models	37
d. Service Information on (DSI and Pilot) Models	38, 39, 40
e. Electrical Connection and Burner Adjustment	41
f. FA-78, DC-82 Series Wiring Diagram for (DSI) Models	42
g. FA-78, DC-82 Series Wiring Diagram for (DSI) Models (with circuit breaker)	42
h. AC-82 Series Wiring Diagram for (DSI) Models (12 VDC System)	43
i. AC-82 Series Wiring Diagram for (DSI) Models (24 VAC System)	43
j. FA-78, DC-82 Series Wiring Diagram for (Pilot) Models	44
WARRANTY REIMBURSEMENT	45

SERVICE GUIDE

Furnaces with Direct Spark Ignition (DSI)

SEQUENCE of Normal Operation (See page 13 for 72 Series)

Each step in this operation must be completed in the sequence listed below before the next function will occur. To properly diagnose a malfunction and correct it, it must be determined at what step the operation of the furnace failed.

1. When the temperature drops to the thermostat set temperature, the wall thermostat contacts close.
2. The fan relay coil is energized, completing the circuit to the blower motor. Note: (Some models have a 5 to 20 second time delay after the thermostat contacts close.)
3. The motor starts, turning the combustion and circulating air blower wheels.
4. When the blower reaches the necessary RPMs to close the air operated sail switch (approximately 1 to 2 seconds), current is supplied through a temperature limit switch to the D.S.I. control module.
5. When energized, this DSI module has a built-in 15 second delay to purge the combustion chamber.
6. The D.S.I. Module supplies a high voltage spark through the high tension lead to the igniter.
7. The gas valve opens.
8. The burner ignites.
9. The sensor signals presence of a flame and sparking stops. (If a flame is not established within 7 seconds, the system closes the gas valve and locks out.)
10. The fan switch closes on temperature rise. (Not applicable to time delay models.)
11. The gas valve closes when either limit switch or thermostat contacts open.
12. The Blower motor stops when the fan switch or time delay relay opens.

GENERAL

Most electrical components, except the motor and sail switch can be checked or replaced while the furnace is installed. Do not use a battery charger to power or test furnace. This could damage the control module or thermostat.

All testing and repair should be done by qualified personnel only.

Do not use a screwdriver or any other metal tool to touch any part of the electrode assembly while the furnace is running.

Do not attempt to operate the furnace with the high tension lead wire disconnected or the electrode assembly removed from the burner plate.

Do not perform any high potential test on these furnaces.

A. Thermostat is calling for heat, but blower does not run.

1. Check for 12 volts DC or 120 volts A.C. at the furnace connection. Correct power source if found to be below 10.5 volts or above 14.5 volts D.C. or if below 105 volts or above 135 volts A.C. See wiring diagrams for your furnace series and model type.
2. Check the circuit breaker. The reset button protrudes 1/4" in the operating (closed) position. When tripped (open), it protrudes 1/2". Check for shorts and excessive voltage and correct problems. Push "IN" to reset.
3. Check all wiring for correct polarity (refer to wiring diagram), loose connections and possible shorts.
4. Check the wall thermostat and wiring for continuity.
5. After correcting above listed problem check for voltage at the orange or red motor lead connection. If "0" VDC, replace relay.

6. If voltage is present at motor lead terminal and the blower wheel is not obstructed and all wiring is good, replace the motor.

B. Blower is noisy

1. Check for debris in wheel or looseness. Remove debris, and tighten the wheel properly. If damaged replace.
2. Check for excessive voltage, and correct.
3. Check polarity. If reversed, motor will whine and run backwards. Air delivery may be too low to close the sail switch.
4. Wheel may be hitting the housing. Adjust the wheel with an Allen wrench.

C. Blower runs but burner does not light

1. Check for possible air in gas lines. Reset thermostat and cycle the furnace several times to bleed the system.
2. Check gas supply pressure while in operation. Supply 11" W.C. pressure to the furnace on all propane units, and 7" W.C. pressure to natural gas series with all gas appliances operating. Make sure the valve knob is in the "ON" position.
3. Check wiring for polarity and continuity.
4. Check for lint and dirt in blower wheel or restrictions in return air passages. Correct or clean.
5. Check for voltage on both sides of limit switch. If there is voltage on one side of the switch but not on the other, replace switch. If there is voltage on both sides of limit switch, proceed to step 6.
6. Observe if sail switch moves forward or up and down (to close contacts) when the blower reaches full RPM. If sail switch is immobile or voltage is not present at both terminals when in closed position, replace the sail switch.
7. Check for voltage at power terminals on control module (refer to wiring diagram). If "0" voltage, check wire from sail switch, for continuity.
8. If sparking is audible approximately 15 seconds after blower starts, but no ignition, check the high tension wire for continuity, grounding and good connections. Repair if defective.
9. Make sure electrodes are not grounding, the gap is 1/8" and the ceramic insulator is not cracked, broken or sooted. Adjust, clean or replace.
10. If sparking is not audible, remove DSI module and observe if the neon bulb on circuit board is flashing during the trial for ignition period. If not remove the white plastic connector from the circuit board. Clean the board terminals with a soft, rubber eraser. Check the terminals in the plastic connector for good contact. If tube still does not flash, replace control module.
11. Check for voltage at the gas valve during the trial for ignition period. If "0" VDC and connections are good, replace the module.
12. If the valve does not open with voltage to valve, replace valve.
13. Electrode sparking, valve open, but the burner will not light. Check the gas supply, vent and air tube installation and blockage. Check for rupture in combustion air hose. Loose hose clamps, loose blowers, and voltage to furnace.
14. Check burner adjustment as shown in each series sections.

D. Burner ignites but shuts off

1. Check sensor adjustments as shown on page 4, fig. 1
2. Check the electrode assembly mounting screws and all ground terminals for tightness.
3. Check continuity through the DSI module to sensor lead.

4. The flame detector circuit uses the ionized gas flame to conduct the flame safe signal. To check, shut off the power, remove the lead from the sensor and insert a 0-50 micro amp-meter in series with the sensor and the sensor wire. Attach "PLUS" terminals of meter to sensor wire and "NEGATIVE" terminal to sensor electrode. Energize the igniter. The reading should be 5 micro amps or higher. (If "0", the leads are reversed.) Adjust or replace the electrode if reading is below 5.
5. If reading is 4 micro amps or above and lockout still occurs, replace the DSI module.

E. Main burner will not shut off

1. Make sure the thermostat and the relay contacts are open.
2. Check voltage at the valve terminals. There should be "0" volts.
3. Disconnect leads from the valve. If the valve does not shut off, replace the valve.

F. Continuous sparking

1. Continuous sparking is caused by separations in the high tension lead wire or poor terminal connections. Repair or replace.

G. Erratic blower and/or thermostat operation

1. Check all wiring to the furnace.
2. Check for shorts in the main wiring.
3. Disconnect leads to the gas valve, if the furnace runs properly with leads removed. Replace the gas valve.

H. Repeated control module failures

1. Check to be sure that the igniter or the high tension lead is not sparking to the sensor or the lead wire.
2. Check the voltage from the coach converter. If over 14½ VDC output is present, adjust or replace the converter.
3. Check to insure that the furnace return air ways and the warm air ducts are not restricted or blocked and the minimum required return air is provided.

**ELECTRODE ADJUSTMENT
FIGURE #1**

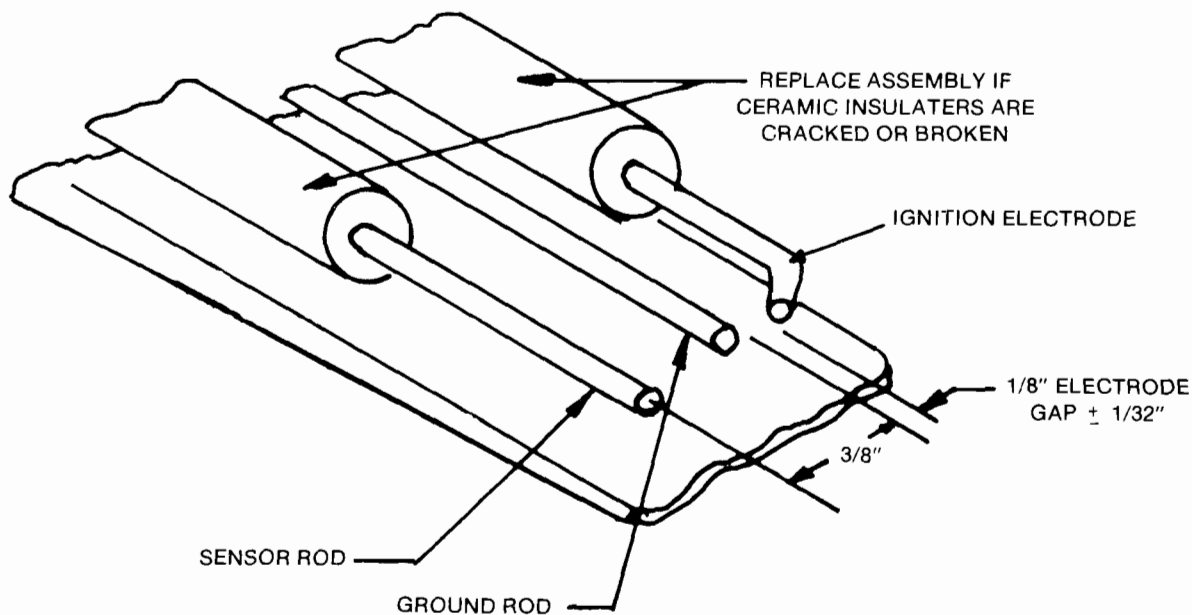

SERVICE GUIDE

Furnaces with Piezo Igniters and Pilot, Thermocouple systems

Sequence of normal operation (See page 15 for 72 Series)

Each step in this operation must be completed in the sequence listed below before the next function will occur. To properly diagnose a malfunction and correct it, it must be determined at what step the operation of the furnace failed.

1. When the temperature drops to a set temperature, the wall thermostat contacts close.
2. The fan relay coil is energized, after a 15 to 20 second delay, completing the circuit to the blower motor.
3. The motor starts, turning the combustion and circulating air blower wheels.
4. When the blower reaches the necessary RPMS to close the air operated sail switch (approximately 1 to 2 seconds), current is supplied through a temperature limit switch to the gas valve.
5. The gas valve opens.
6. The pilot flame ignites.

GENERAL

Most electrical components, except the motor and sail switch, can be checked or replaced while the furnace is installed. All testing and repair should be done by qualified personnel only.

A. Thermostat is calling for heat, but blower does not run

1. Check for 12 volts DC or 120 volts AC at the furnace connection. Correct power source if found to be below 10.5 volts or above 14.5 volts D.C. or if below 105 volts or above 135 volts A.C. See wiring diagram for your furnace series and model type.
2. Check the circuit breaker. The reset button protrudes 1/4" in the operating (closed) position. When tripped (open), it protrudes 1/2". Check for shorts, excessive voltage and correct problems. Push "IN" to reset. (FA-78, not equipped with a manual reset breaker.)
3. Check all wiring for correct polarity (refer to wiring diagram located within each section for your series unit), loose connections and possible shorts or open circuits.
4. Check the wall thermostats wiring for continuity. Note: Wire installed with staples is subject to shorts.
5. After correcting above listed problem, check for voltage at orange or red motor lead connection. If "0" VDC, replace relay.
6. If voltage is present at motor lead terminal and the blower wheel is not obstructed, all wiring is good, replace the motor.

B. Blower is noisy

1. Check for debris in the wheel or damage or looseness. Remove debris and tighten wheel properly. If damaged replace.
2. Check for excessive voltage, and correct.
3. Check polarity. If reversed, the motor will whine and run backwards. Air delivery may be too low to close the sail switch.

C. Blower runs but burner does not light

1. Check for possible air in gas lines. Reset thermostat and cycle furnace several times to bleed the system.
2. Check gas supply pressure while in operation. Supply 11" W.C. pressure to the furnace on all propane units, and 7" W.C. pressure to natural gas series with all appliances operating. Make sure the valve knob is in the "ON" position.

3. Check the wiring for polarity and continuity.
4. Check for lint and dirt in blower wheel or restrictions in return air passages. Correct or clean.
5. Check for voltage on both sides of limit. If there is voltage on one side of the switch but not on the other, replace switch. If there is voltage on both sides of limit switch, proceed to step 6.
6. Observe if sail switch moves forward or up and down (to close contacts) when the blower reaches full RPM. If sail switch is immobile or voltage is not present at both terminals when in closed position, replace the sail switch.
7. If the valve does not open with voltage to valve, replace valve.
8. If valve opens, but the burner will not light, check the gas supply, vent and air tube installation, check for rupture in combustion air hose, loose hose clamps, loose set screws on combustion air wheel or low voltage to the furnace.

D. Main burner will not shut off

1. Make sure the thermostat and relay contacts are open.
2. Check voltage at valve terminals. There should be "0" volts.
3. Disconnect the leads from the valve. If the valve does not shut off, replace the valve.

E. Erratic blower and/or thermostat operation

1. Check the wiring to the furnace.
2. Check for shorts and open circuits in the wiring.
3. Disconnect leads from the gas valve, if the furnace runs properly replace the gas valve.

F. Pilot will not light

1. Disconnect piezo lead, hold 3/16" from ground, depress plunger, check for spark. If none exists, replace piezo assembly. If spark is visible, remove pilot or burner assembly and adjust the igniter. (Refer to figure 2 on page 6.)
2. Set the thermostat to turn blower on to purge the combustion chamber. Light the pilot.
3. If pilot goes out when the valve knob is turned from "PILOT" to "ON" repeat step 2.
4. If the pilot goes out when the main burner ignites, adjust pilot and check for malfunctioning sail switch.
5. If the main burner will not come on. See sections A, B, C.
6. Main burner will not shut "OFF." See section D.

G. Pilot will not stay lit

1. Check the vent installation.
2. Cut off rain deflector from back of the air box, see HF 77 Series, fig. 10 page 26.
3. Check burner plate for loss mica or holes. Seal all holes in the burner plate.

H. Burner pop when lighting

1. Check adjustment gap between electrode and thermocouple as shown below.
2. Adjust burner head as shown in each series section of this manual.

PILOT ELECTRODE ADJUSTMENT
FIGURE #2

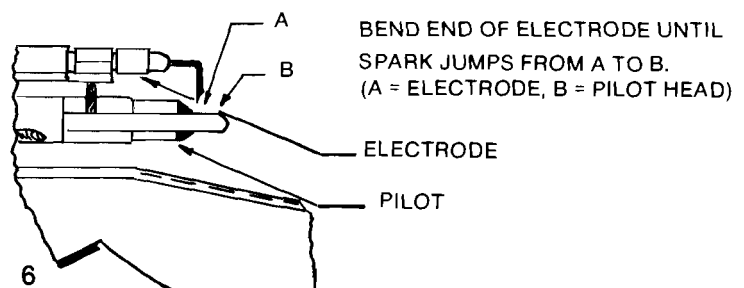

PIEZO IGNITOR
FIGURE #3a

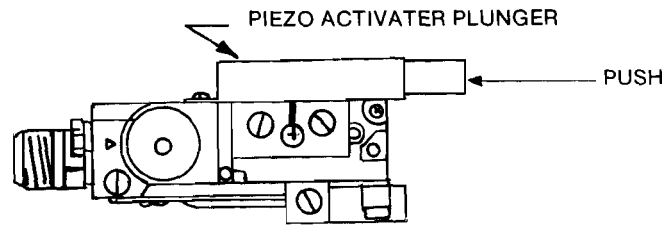

PILOT VALVE SERVICING

A. Pilot model valve gas adjustment

1. Remove pilot adjustment cover screw (see figure #3d) and turn pilot adjustment screw to produce non-blowing blue flame covering top 1/4" of thermocouple tip. Replace cover screw.

B. Pressure regulator adjustment

1. To adjust regulator, remove pipe plug (see figure #3d) from 1/8" NPT pressure tap near valve outlet and install pressure measuring device. Remove cover screw (see figure #3d) to uncover regulator adjustment screw. Adjust pressure to value stamped on valve. Replace cover screw.
2. If valve fails to hold open within 60 seconds after a satisfactory pilot flame is established, check with millivoltmeter or: (1) check appearance and adjust pilot flame, (2) tighten "G" bushing, as shown in figure 3b and make connection to millivoltmeter (3) substitute new thermocouple, (4) replace gas valve.

C. Millivoltmeter test

1. Use 0-50 millivolt scale. Place meter test probes as shown below. If meter needle moves to left of zero or no reading is indicated, reverse probes. Take all readings with pilot burning and thermostat contacts closed. If reading is less than 7 millivolts: (1) adjust pilot gas, (2) clean primary air holes, (3) clean pilot burner orifice, (4) replace thermocouple.
2. If reading is 7 millivolts or more and thermomagnet will not hold open, replace valve.

TEST LEAD CONNECTION
FIGURE #3b

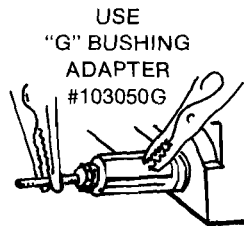

D. Lighting procedure

1. Turn to PILOT. Press dial in and light pilot. Hold for 60 seconds and release.
2. Turn dial counterclockwise to ON. Use this position for main burner-on control.
3. For complete shutdown turn dial clockwise to PILOT, press dial in and turn to OFF. Use this position when complete shutdown is necessary. (Use PILOT position for temporary shutdown.)

VALVE KNOB POSITIONS
FIGURE #3c

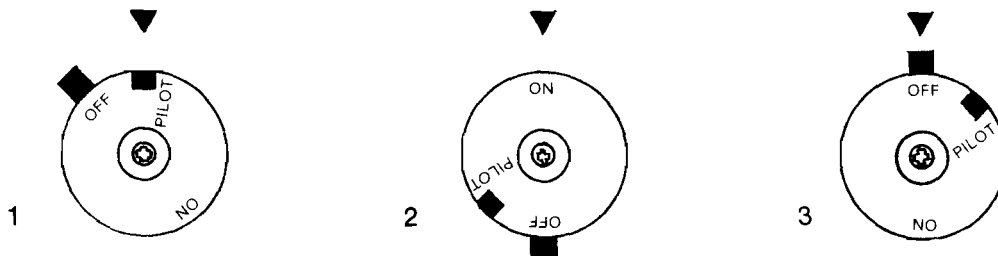

VALVE
FIGURE #3d

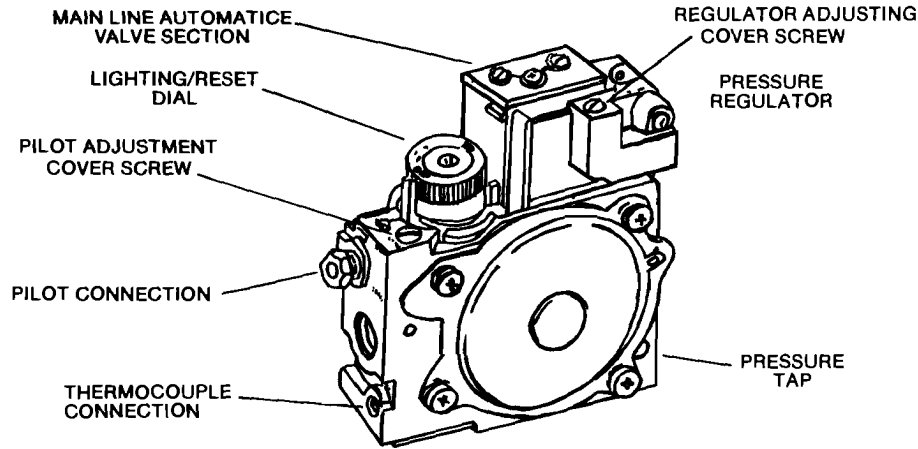

E. Warning

1. Disassembly, reassembly or internal adjustment without factory test may result in hazardous condition. If control does not operate properly after following the INSTALLATION and SERVICE instructions, complete control must be replaced by qualified person.

SERVICE SUGGESTIONS

Trouble	Possible cause	Remedy
Pilot will not stay open after carefully following lighting instructions.	Pilot flame too small or yellow in color due to restricted pilot line, dirt in primary air opening or burner head, wrong orifice in pilot, drafts deflecting pilot flame	Clean pilot line, primary line opening and burner head...Change pilot orifice. Eliminate source of draft.
	Loose or dirty thermocouple connection	Disconnect thermocouple from valve, clean contact with fine sandpaper. Tighten finger tight plus 1/8 turn.
	Thermocouple producing insufficient millivoltage	Check with millivoltmeter, replace if necessary
Pilot burns, thermostat set to call for heat, main valve will not open	Main valve assembly damaged	Replace valve.
Main valve leaks or will not close	Main valve assembly damaged	Replace valve

VENTS

Schematic Number	Order Number		Exhaust Tube No.	Air Box No.	Vent Kit No.	Model No.	"A" Dimension Min/Max Length
	Old	New					
38 A	F-26	76A	1649	1651	2012	FA-76 &	0" - 4 1/2"
38 B	F-30	76B	1648	1650	2013	HF-77	4 1/2" - 7 1/2"
****	**	**	****	****	****	****	*****
229 A	D-24	79A	1680	1677	2150	FA-79 &	0" - 3 1/2"
229 B	D-28	79B	1679	1676	2151	HF-80	3 1/2" - 7 1/2"
229 C	D-32	79C	1678	1675	2145		7 1/2" - 11 1/2"
****	**	**	****	****	****	****	*****
220 A	F-27	82A	1659	2134	2000	DC	0" - 3 1/2"
220 B	F-29	82B	1659	2133	2001	8225 &	3 1/2" - 6 1/2"
220 C	F-32	82C	1660	2132	1998	8232	6 1/2" - 8 1/2"
****	**	**	****	****	****	****	*****
220 D	F-27	82D	2135	2134	1936	AC/DC	0" - 3 1/2"
220 E	F-29	82E	2135	2133	1935	8235 &	3 1/2" - 6 1/2"
220 F	F-32	82F	2137	2132	1934	8241	6 1/2" - 8 1/2"

"Minimum to maximum lengths are taken from back of furnace to outside of coach."

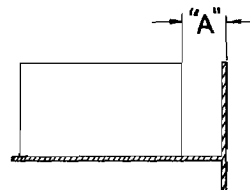

FA-72 SERIES PARTS SCHEMATIC

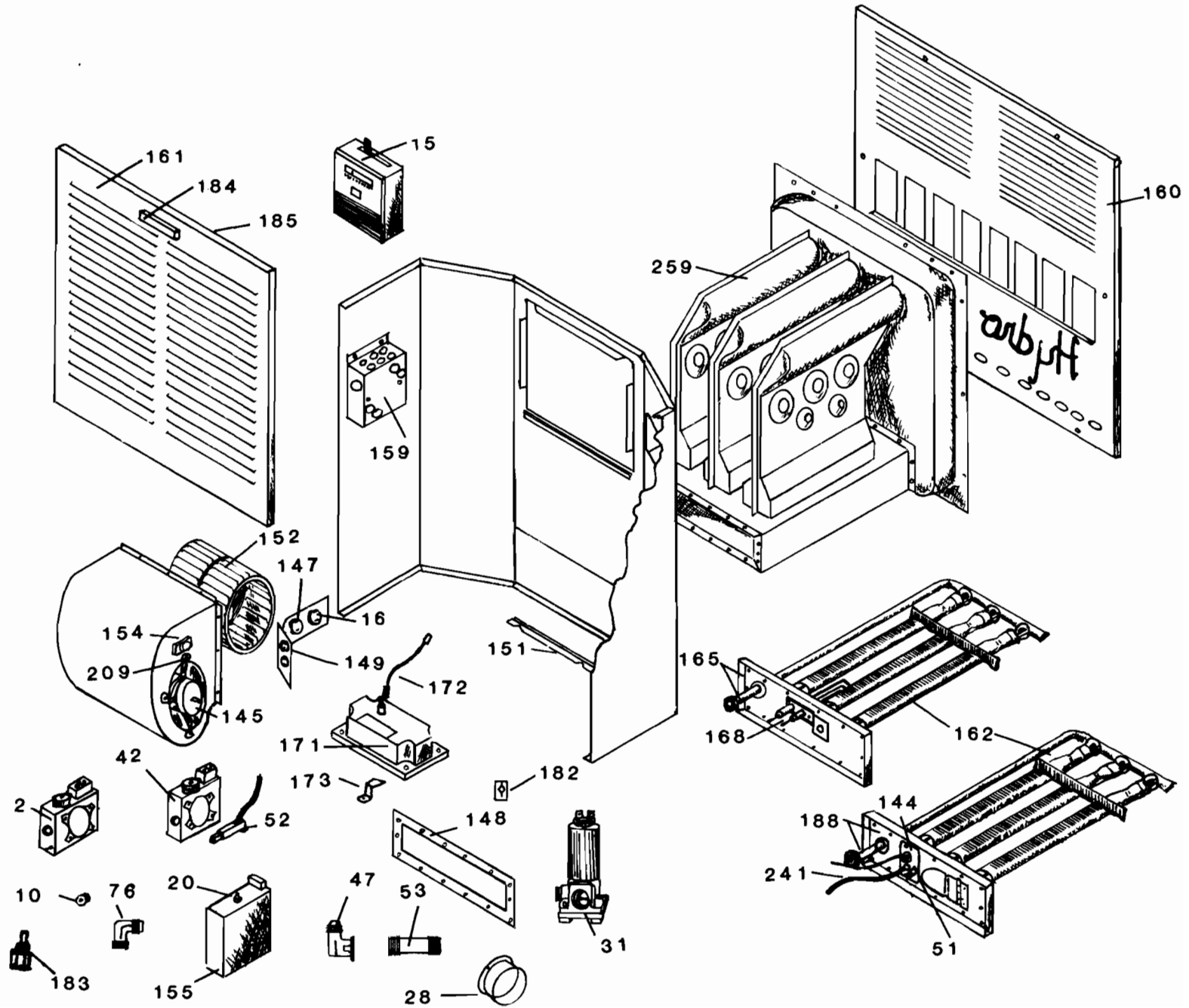

PARTS PRICE LIST

FA-72 Series DSI and Pilot Models

Schematic Number	Description	Service Center	Retail
2	72 DSI, ITT Valve RV28SBR59	\$ 62.01	\$ 90.94
10h	#66 Orifice (All units)	.63	.91
15	Thermostat JT 2B-01	14.02	20.57
16	Limit 60T11 200740	5.54	7.98
20a	5 amp Circuit Breaker 44-100P10	8.38	12.07
28	Duct Adapters	2.26	3.25
31	Fenwal Valve SPR-10	44.72	64.40
42	ITT Pilot Valve RV28SB49	64.62	94.77
47	3/8 x 3/8 Female Ell 150F-6-6	2.40	3.46
50	Jade Thermocouple TN2-14	4.70	6.77
51	Piezo Electrode	2.60	3.74
52	Piezo Sparker	10.10	14.54
53	3/8 x 2½ Black Nipple	1.30	2.85
76	3/8 x 3/8 Brass Male Ell 149F-6-6	1.87	2.69
143	Honeywell Valve V8500A-1017	74.05	106.63
144	Pilot 26C1762TV009	7.44	10.71
145	Blower Motor PE2423Q	39.32	56.62
147	Fan Switch 60T12 201375	5.54	7.98
148	Burner Door Gasket	1.01	1.48
149a	DSI Fenwal Limit Arm Assembly	25.21	36.30
149b	Pilot Limit Arm Assembly	25.21	36.30
149c	DSI ITT Limit Arm Assembly	25.21	36.30
150a	Pilot ITT Wire Harness Assembly (12 volt)	22.61	32.56
150b	DSI Fen Wire Harness Assembly (12 volt)	22.61	32.56
150c	Pilot ITT Wire Harness Assembly (120 volt)	22.61	32.56
150d	DSI Fen Wire Harness Assembly (120 volt)	22.61	32.56
150e	DSI ITT Wire Harness Assembly (12 volt)	22.61	32.56
150f	DSI ITT Wire Harness Assembly (120 volt)	22.61	32.56
151	DSI Board Bracket	3.01	4.33
152	Blower Wheel Fed 519-305-216-1	16.89	24.32
154	Manual Reset Limit	8.46	12.18
155a	Junction Box Assembly 12 volt Pilot	33.96	48.90
155b	Junction Box Assembly 120 volt Pilot	33.96	48.90
155c	Junction Box Assembly 12 volt DSI	34.23	50.21
155d	Junction Box Assembly 120 volt DSI	34.23	50.20
156	On-Off 1-Way Switch	2.97	4.28
157	Pilot Honeywell Control & Burner Assembly (3 cell)	128.83	185.52
159	Converter With Box Assembly	58.74	86.15
160	Exterior Grill Assembly	18.54	26.69
161	Interior Grill Assembly	15.98	23.01
162	Burner Assembly (3 cell)	36.43	52.46
165	DSI Burner Door and Manifold Assembly (3 cell)	65.70	94.61
168	Fenwal Electrode 05-100000-446	11.54	16.93
170	DSI ITT Control and Burner Assembly (3 cell)	140.40	202.17
171	DSI Board 05-152436-002	47.61	69.82
172	High Tension Lead Wire Assembly	5.54	7.98
173	DSI Retaining Clip	.46	.66
182	Burner Support Clip	.76	1.09
183a	Pilot Orifice TV009 ITT	2.74	3.95
183b	Pilot Orifice TV008 ITT	2.74	3.95
184	T-Handle	1.25	1.80

PARTS PRICE LIST FA—72 SERIES DSI AND PILOT MODELS CONTINUED

Schematic Number	Description	Service Center	Retail
185	Door Latch	\$ 1.10	\$ 1.58
186	2-Way Toggle Switch	8.58	12.36
188	Pilot Burner Door and Manifold Assembly	14.41	20.75
192	DSI Fenwal Control & Burner Assembly (3 cell)	140.40	202.17
209a	Motor Bracket Assemably (DC) II)	5.66	8.15
212	Pilot ITT Control & Burner Assembly (3 cell)	61.76	88.93
241	Pilot Tube Assembly	8.00	11.52
259	3 Cell Chamber Assembly	81.85	117.86
265	Fenwal Dpr-10 Valve	50.27	73.74
270	Gas Ignition Board Field Tester	85.00	105.25

**FLAT RATE LABOR SCHEDULE
FA-72 Series D.S.I. Model**

Schematic Number	Description of Replacement Part	Set Up Time	Replacement Time
2	Gas Valve	30 min.	30 min.
145	Fan Motor	30 min.	15 min.
16, 147	Limit Switch -- Fan switch	30 min.	15 min.
148	Burner door Gasket	30 min.	15 min.
150	Wiring Harness Complete	30 min.	30 min.
10	Main Burner Orifice	30 min.	30 min.
152	Blower Wheel	30 min.	15 min.
168	Electrode assembly	30 min.	10 min.
162	Burners 3 Cell	30 min.	30 min.
154	Manual Reset Switch	30 min.	15 min.
155	Junction Box AC-DC	30 min.	20 min.
156	ON-OFF Switch (DC only)	30 min.	20 min.
20	Circuit Breaker	30 min.	20 min.
186	AC-DC Switch	30 min.	20 min.
182	Burner support Clips		5 min.
192, 170	Complete Burner Assembly 3 Cell		30 min.
15	Thermostat	30 min.	5 min.
159	Convertor	30 min.	15 min.
171	Control Module	30 min.	10 min.
172	High Tension Lead Assembly	30 min.	5 min.
160	Exterior Grill	30 min.	15 min.
161	Interior Door		5 min.
184	T-Handle	15 min.	15 min.
185	Door Latch		5 min.
173	Module Board Clip		5 min.
149	Fan & Limit Arm Assembly	30 min.	30 min.

NOTE: When more than one component is defective, compute the total of both replacement times, but only one set up time.

FLAT RATE LABOR SCHEDULE FA-72 Series Pilot Model

Schematic Number	Description of Replacement Part	Set Up Time	Replacement Time
2,42,143	Gas Valve Honeywell/ITT	30 min.	30 min.
52	Piezo Sparker	30 min.	15 min.
144	Pilot	30 min.	15 min.
145	Fan Motor	30 min.	15 min.
16, 147	Limit Switch — Fan Switch	30 min.	15 min.
148	Burner door Gasket	30 min.	15 min.
150	Wiring Harness Complete	30 min.	30 min.
10	Main burner Orifice	30 min.	30 min.
152	Blower wheel	30 min.	15 min.
51	Sparker electrode	30 min.	15 min.
183	Pilot Orifice	30 min.	15 min.
162	Burners — 3 Cell	30 min.	30 min.
154	Manual Reset Switch	30 min.	15 min.
155	Junction Box AC-DC	30 min.	30 min.
156	ON-OFF Switch (DC only)	30 min.	20 min.
20	Circuit Breaker	30 min.	20 min.
186	AC-DC Switch	30 min.	20 min.
182	Burner Support Clip		5 min.
50	Thermocouple	30 min.	10 min.
212, 157	Burner Assembly Complete 3 Cell	30 min.	30 min.
15	Thermostat	30 min.	5 min.
159	Convertor	30 min.	15 min.
160	Exterior Grill		15 min.
161	Interior Door		5 min.
184	T-Handle	15 min.	15 min.
185	Door Latch		5 min.
149	Fan and Limit Arm Assembly	30 min.	30 min.

NOTE: When more than one component is defective, compute the total of both replacement times, but only one set up time.

SERVICE GUIDE

FA-72 Series DSI Model

Sequence of Normal Operation

Each step in this operation must be completed in the sequence listed below before the next function will occur. To properly diagnose a malfunction and correct it, it must be determined at what step the operation of the furnace failed.

1. When the temperature drops to a set temperature, the wall thermostat contacts close.
2. Current is supplied through a temperature limit switch to the D.S.I. control module.
3. The D.S.I. Module supplies a high voltage spark through the high tension lead to the igniter.
4. The gas valve opens.
5. The burner ignites.
6. The sensor signals the presence of a flame and sparking stops. (If a flame is not established within 7 seconds, the system closes the gas valve and locks out.)
7. The fan switch closes on temperature rise. Blower starts circulating warm air flow.
8. The gas valve closes when either the limit switch or thermostat contacts open.
9. The blower motor STOPS when fan switch or manual reset limit opens.

GENERAL

All electrical components can be checked or replaced while the furnace is installed. Do not use a battery charger to power or test furnace as this could damage the control module or thermostat.

All testing and repairs should be done by qualified personnel only.

Do not use a screwdriver or other metal tool to touch any part of the electrode assembly while the furnace is running.

Do not attempt to operate furnace with the high tension lead wire disconnected or electrode assembly removed from the burner plate.

Do not perform any high potential test on these furnaces.

A. Burner does not light when thermostat calls for heat

1. Check for possible air in gas lines. Reset thermostat and cycle furnace several times to bleed system.
2. Check gas supply pressure while in operation supply 11" W.C. pressure to the furnace. Make sure the valve knob is in the on position, the switch on the side of the junction box is on and the circuit breaker is pushed in. Check manual reset switch located on the side of the blower housing.
3. Check for voltage at the terminals of the control module (D.S.I. board; refer to wiring diagram). If "0" VDC, check thermostat wires, manual and high limits. Power should be present between all of these components and ground.
4. If sparking is audible immediately after thermostat contacts close, but there is no ignition, check the high tension lead for continuity, grounding and good connection. repair if defective.
5. Make sure the electrode is not grounded. The gap should be 1/8" and the ceramic insulator should not be cracked, broken or sooted. Adjust, clean or replace. (See figure 4 page 15.)
6. If sparking is not audible, remove the DSI module cover and observe if the neon bulb on circuit board is flashing during the trial for ignition period. Remove the white plastic connector from the DSI module board. Clean the board terminals with a soft rubber eraser. Check the terminals in the plastic wire connector for good contact. If tube still does not flash, replace the DSI control module.
7. Check for voltage at the gas valve during the trial for ignition period. If "0" VDC and connections are good, replace the D.S.I. board.

SERVICE GUIDE FA-72 SERIES DSI MODEL CONTINUED

8. If the gas valve does not open with voltage to it, replace the gas valve.
9. Electrode sparking, valve open, but the burner will not light. Check the gas supply, proper vent installation, low voltage to furnace and sparking gap and spacing as per figure 4.

B. Burner on — fan will not come on

1. Check all wiring for correct polarity (refer to wiring diagram) in this section.
2. After burner has been on for five minutes, check for completed circuit through fan switch. If circuit not completed, replace fan switch.
3. Check for voltage at motor leads. If voltage is present and blower wheel is not obstructed, replace motor.

C. Burner ignites but shuts off

1. Check sensor adjustment. (See figure 4.)
2. Check the electrode assembly mounting screws and all ground terminals for tightness.
3. Check continuity through the DSI module to sensor lead.
4. The flame detector circuit uses the ionized gas flame to conduct the flame safe signal. To check, shut off the power, remove the lead from the sensor and insert a 0-50 micro ammeter in series with the sensor and the "NEGATIVE" terminal to sensor electrode. Energize the igniter. The reading should be 5 micro amps or higher. (If "0", reverse the leads.) Adjust or replace the electrode if reading is below 5.
5. If reading is good and lockout still occurs, replace the DSI module.

D. Main burner will not shut off

1. Make sure the thermostat contacts are open.
2. Check voltage at valve terminals, voltage should be "0" volts.
3. Disconnect the leads from the valve. If the valve does not shut off, replace the valve.

E. Continuous sparking

1. Continuous sparking is caused by separations in the high tension lead wire or poor terminal connections. Repair or replace.

F. Erratic blower and/or thermostat operation

1. Check the wiring to the furnace.
2. Check for shorts and open circuits in wiring.
3. Disconnect leads to the gas valve, if the furnace runs properly with the leads removed. Replace the gas valve.

G. Repeated control module failures

1. Check to be sure that the igniter or the high tension lead is not sparking to the sensor or the lead wire.
2. Check the voltage from the coach converter. If over 14½ VDC output is present, adjust or replace the converter.

H. Blower is noisy

1. Check for debris in the wheel or damage or looseness. Remove debris, and tighten wheel properly. If damaged replace.
2. Check for excessive voltage, and correct.
3. Check polarity. If reversed, the motor will whine and run backwards.
4. The wheel may be hitting housing; adjust wheel position with Allen wrench.
5. Check for loose motor mounts and retighten.

ELECTRODE ADJUSTMENT
FIGURE #4

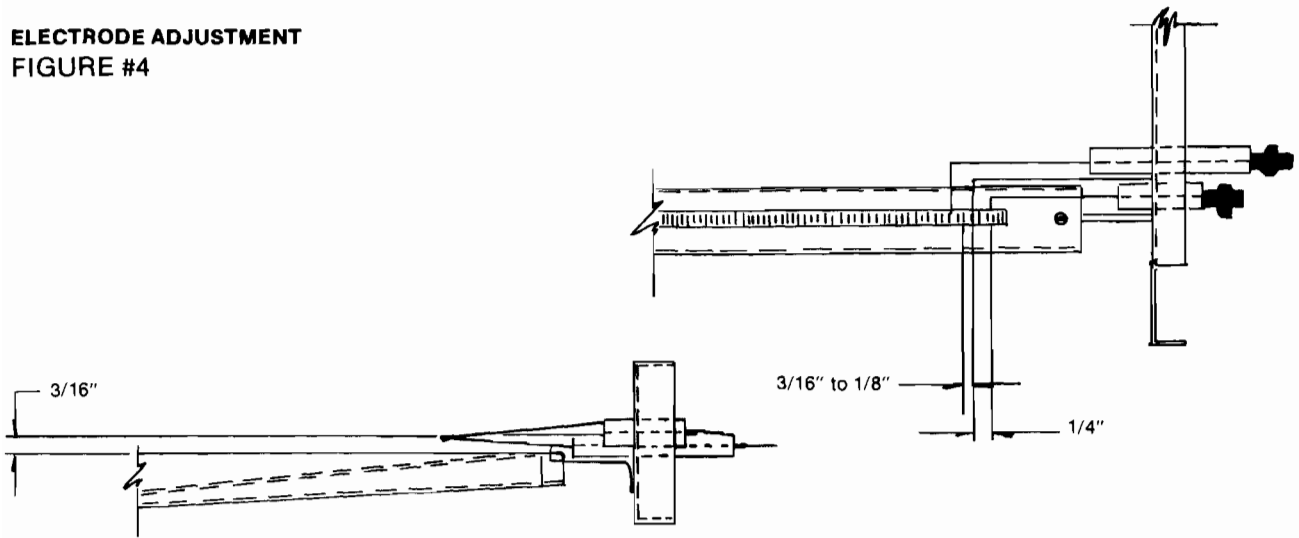

SERVICE GUIDE
FA-72 Series Pilot Model

Problem	Cause	Solution
Pilot will not light	1. No fuel	Check fuel supply.
	2. Blocked fuel lines	Check for kinks or other blockage and replace.
	3. Plugged pilot orifice	Clean with air pressure or replace. (Check for spider webs in pilot and pilot orifice.)
	4. Regulator out of adjustment	Adjust regulator to 11 inches water column.
	5. Bad pilot adjustment	Check pilot adjustment screw.
	6. Regulator freezing	Insert 1/2 cup methylhydrate into empty gas bottle.
	7. Inoperative control valve	Replace control valve.
Pilot will not stay lit when knob has been released	1. Loose thermocouple at control valve	Tighten thermocouple finger tight plus 1/4 turn
	2. Dirty thermocouple connection	Clean with emery paper and replace
	3. Partially plugged pilot orifice	Clean with air pressure or replace.
	4. Bad adjustment at pilot and/or regulator	Check and adjust
	5. Faulty thermocouple	Check for millivolt output and replace if faulty. MIN. 5 MV closed circuit, 13 MV open circuit.
Pilot outage	1. Dirty orifice	Clean with air pressure or replace.
	2. Regulator freezing	Insert 1/2 cup methylhydrate into empty gas bottle. NOTE: If bottle is full, insert a few drops of methylhydrate into line at P.O.L. fitting.
Main burner will not fire	1. Pilot knob not at ON position	Turn pilot knob to ON position.
	2. Toggle switch OFF	Turn toggle switch to ON position. Check voltage at valve.

Problem	Cause	Solution
Main burner will not fire	3. Manual reset limit switch open	Push to reset limit (right side of blower housing). Check voltage at valve.
	4. High limit switch faulty	Replace if continuity test shows faulty. Check voltage at valve.
	5. Inoperative control valve with 12 VDC at valve	Replace control.
	6. Bad thermostat	Replace thermostat.
	7. Circuit breaker out and/or faulty	Reset and/or replace.
	8. Manual reset out	Push to reset.
	9. Broken wire to thermostat	Replace wire.
	10. Poor connection in wiring harness	Check connections to make sure they are tight.
Main burner will not shut down	1. Short in thermostat wire	Replace thermostat wire.
	2. Thermostat mounted in cold location	Relocate.
	3. Operative control with no voltage at valve	Replace control.
Fan will not come on	1. No 12 volt power to motor	Check 12 v. power to motor.
	2. Faulty 115° fan switch	Replace fan switch.
	3. Seized or burned out motor	Replace motor.
Fan will not shut off	1. Faulty 115° fan switch, will not open	Replace fan switch.
	2. Obstructed ducting	Check for obstruction and clean.
Furnace fails to operate with wall thermostat	1. Short in wire to wall thermostat	Check by unhooking W.T. wires at control and use jumper wire. If furnace ignites, replace wire.
	2. Control hooked to 12 volt power	Replace control.
	3. Faulty wall thermostat	Check by crossing wires at W.T.
Blower noisy	1. Debris inside blower wheel	Remove debris and clean wheel.
	2. Motor mounts loose	Retighten.
	3. Blower wheel loose on shaft	Adjust and tighten
	4. Reversed motor polarity, motor running backwards	Wire for correct polarity.
	5. Loose blower assembly	Tighten screws between blower housing and fan support wall.
	6. Blower wheel out of balance	Replace wheel.
Leaking valve	1. Overfilled gas bottle	Replace valve. Check bottle. (Not covered by warranty.)
	2. Valve subjected to high pressure test	Replace valve. (Not covered by warranty.)
Odors	1. Obstructed vent	Check for obstruction.
	2. High pressure gas	Check gas pressure setting.
Humming noise	Convertors on AC units	This is normal.

NOTE: Model numbers are shown on the lighting instruction plates. Serial numbers are located on the Underwriters Laboratories plate or Agency listing label.

FA-72 SERIES WIRING DIAGRAM FOR DSI MODELS

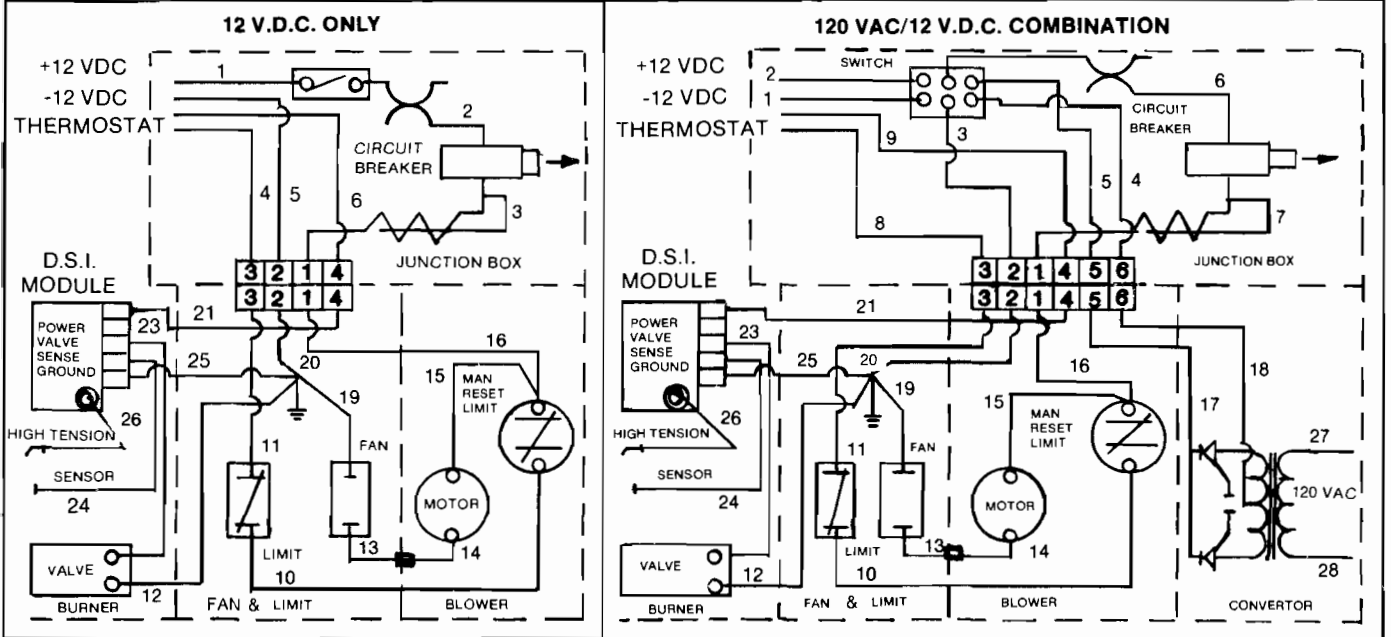

FA-72 SERIES WIRING DIAGRAM FOR PILOT MODELS

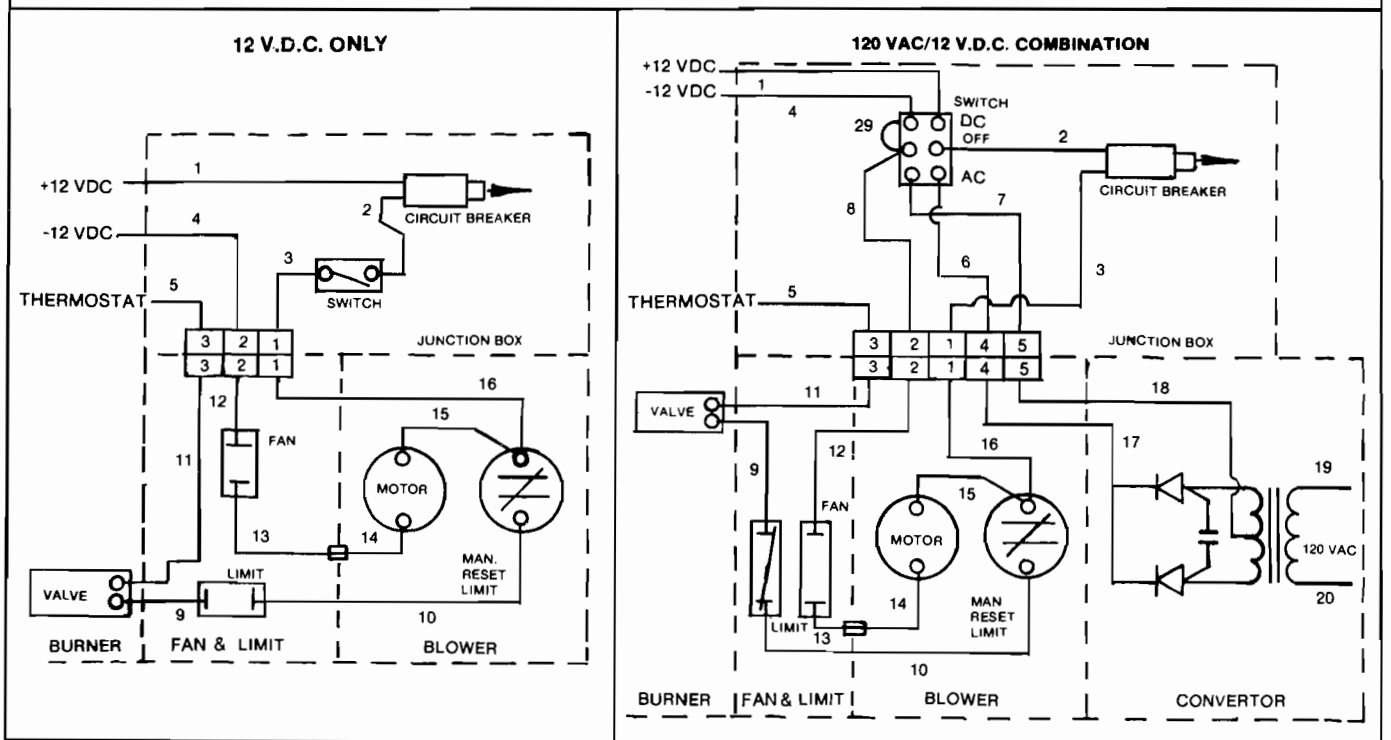

FA-76 SERIES PARTS SCHEMATIC

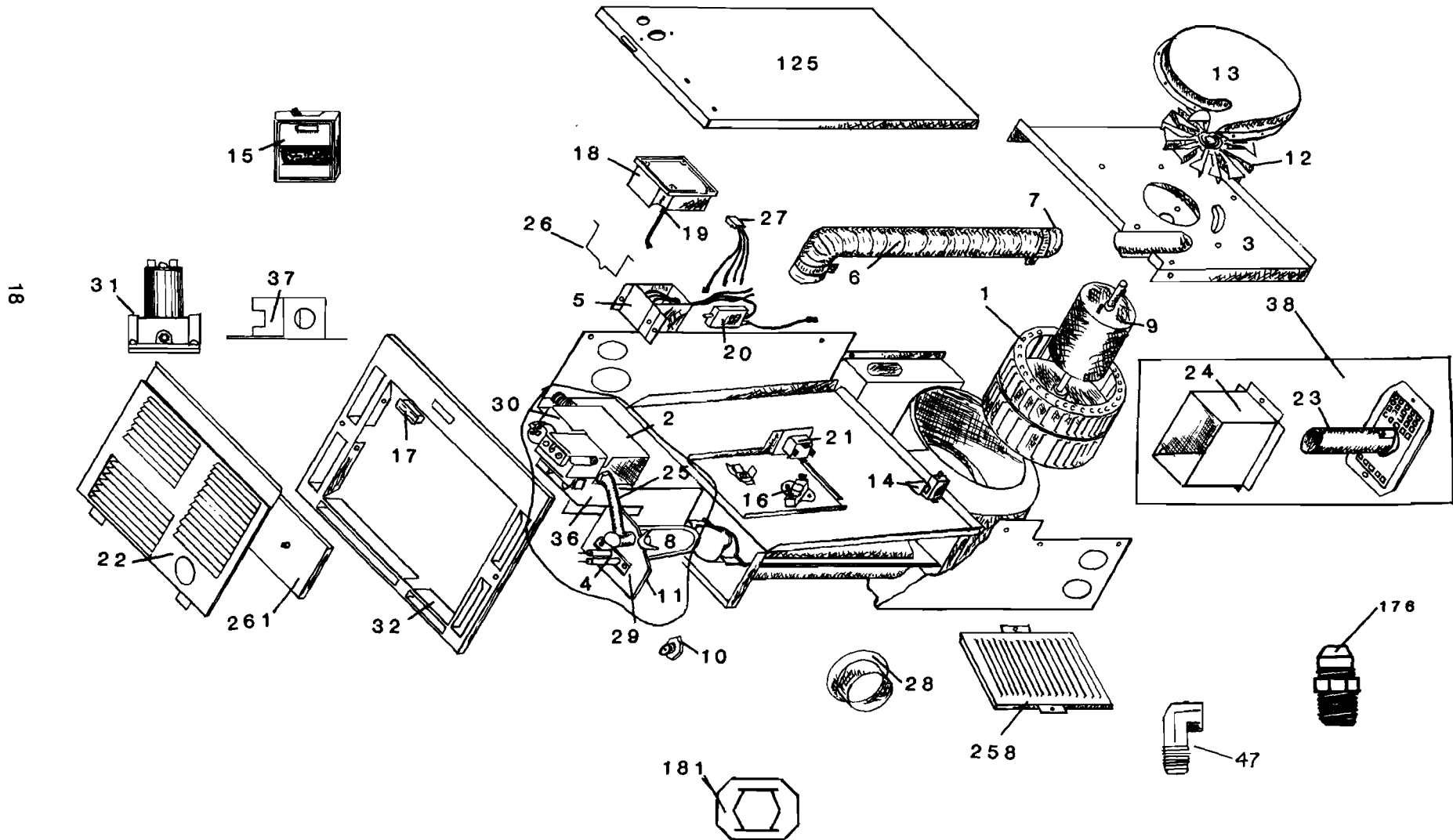

PARTS PRICE LIST

FA-7615 Series DSI Model

Schematic Number	Description	Service Center	Retail
1	Blower Wheel Fed 519-119-1	\$ 16.58	\$ 23.88
2	DSI ITT Valve RV28SBR59	62.01	90.94
3	Motor Mount Assembly	11.18	16.10
4	DSI Electrode 22-100000-466	11.98	17.25
5	Junction Box Assembly	14.49	20.87
6	Combustion Air Hose	7.99	11.51
7	Hose Clamp (one)	.57	.82
8	Burner Head Assembly	12.45	17.93
9	Motor PF-2040Q	35.39	50.96
10e	#59 Orifice	.63	.91
11	DSI Burner Plate Gasket	.75	1.08
12	Combustion Air Wheel A28638	6.18	8.90
13	Combustion Blower Housing	6.12	8.81
14	Sail Switch Assembly	9.79	14.10
15	Thermostat JT2B-01	14.02	20.57
16	Limit 60T11 200740	5.54	7.98
17	Magnet Door Latch FL40	1.47	2.12
18	DSI Board 152436-103	52.89	77.57
19	High Tension Lead Assembly	4.77	6.87
20a	5 Amp Circuit Breaker 44-100P10	8.38	12.07
21	Klixon Relay 60704A0-18	9.32	13.42
22	Door Front Assembly	15.97	23.00
23a	76A Exhaust Tube Extension Assembly	8.46	12.18
23b	76B Exhaust Tube Extension Assembly	8.46	12.18
24a	76A Air Box Extension Assembly	6.44	9.27
24b	76B Air Box Extension Assembly	6.44	9.27
25	Manifold	8.00	11.52
26	DSI Wire Retainer	1.87	2.69
27a	ITT DSI Wire Harness Assembly Complete	30.00	44.00
27b	Fenwal DSI Wire Harness Assembly Complete	30.00	44.00
27d	Fenwal DSI Wire Harness DRP-10 Assembly Complete	30.00	44.00
28	Duct Adapters	2.26	3.25
29	DSI Burner Plate and Gasket Assembly	5.17	7.44
30a	ITT DSI Control and Burner Assembly	101.42	146.04
30b	Fenwal DSI Control and Burner SPR-10 Assembly	101.42	146.04
30d	Fenwal DSI Control and Burner DPR-10 Assembly	101.42	146.04
31	Fenwal Valve SPR-10	44.72	64.40
32	Door Frame	8.99	12.87
36	Valve Mounting Bracket ITT	4.42	6.08
37	Fenwal Valve Mounting Bracket	4.42	6.08
38a	76A Vent Kit Assembly	14.87	21.41
38b	76B Vent Kit Assembly	14.87	21.41
47	3/8 x 3/8 Female EII 150F-6-6	2.40	3.46
53	3/8 x 2½ Black Nipple	1.30	2.85
76	3/8 x 3/8 Brass Male EII 149F-6-6	1.87	2.69
125	Casing Top	10.50	15.12
176	3/8 x 3/8 Brass Female Straight 48FX-6-6	3.47	5.00
181	Manifold Retaining Clip	.76	1.09
258	Blower Grille	7.62	10.97
261	Front Discharge Cover	1.70	2.97
265	Fenwal VALve DPR-10	50.27	73.74
270	Gas Ignition Board Field Tester	85.00	105.25
271	76 Dpr-10 Valve Bracket Assembly	9.46	13.01

FLAT RATE LABOR SCHEDULE

FA-7615 Series

Schematic Number	Description of Replacement Part	Set Up Time	Replacement Time
1	Circulating Air Wheel	30 min.	30 min.
2	Gas Valve	30 min.	30 min.
3	Blower Plate	30 min.	30 min.
4	Electrode	30 min.	15 min.
5	Junction Box Assembly	30 min.	15 min.
6	Combustion Air Hose	30 min.	20 min.
7	Hose Clamps	30 min.	10 min.
8	Burner Head	30 min.	30 min.
9	Motor	30 min.	40 min.
10	Main Burner Orifice	30 min.	30 min.
11	Burner Plate Gasket	30 min.	30 min.
12	Combustion Air Wheel	30 min.	40 min.
13	Combustion Air Housing Cover		15 min.
14	Sail Switch Assembly	30 min.	20 min.
15	Thermostat	30 min.	10 min.
16	Limit switch	30 min.	15 min.
17	Door Magnet		10 min.
18	Control Module (DSI)	30 min.	15 min.
19	High Tension Lead Assembly	30 min.	5 min.
20	Circuit Breaker	30 min.	15 min.
21	Relay	30 min.	15 min.
22	Door		10 min.
23	Vent Cap with Exhaust Tube		15 min.
24	Inlet Air Box Extension		15 min.
25	Manifold	30 min.	30 min.
26	DSI Support Wire		10 min.
27	DSI Wiring Harness (ITT/Fenwal) complete		30 min.
29	Burner Plate With Gasket and Window		10 min.
30	Burner Control Assembly		15 min.
181	Manifold Retaining Clip	30 min.	30 min.
32	Door Frame		5 min.

NOTE: When more than one component is defective, compute the total of both replacement times, but only one set up time.

FA-76 ELECTRICAL CONNECTION
FIGURE #5

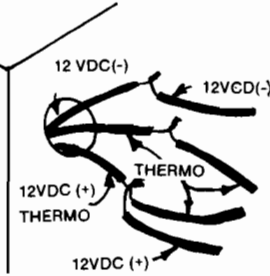

FA-76 BURNER ADJUSTMENT
FIGURE #6

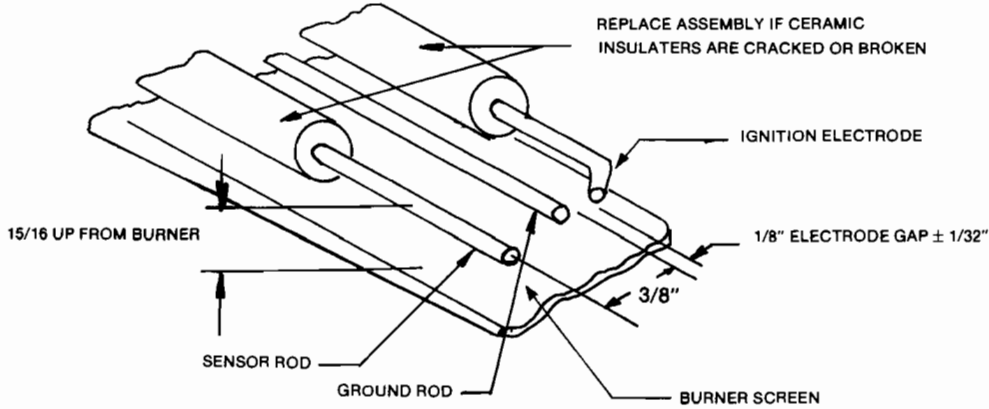

FA-76 SERIES WIRING DIAGRAM FOR (DSI) MODELS

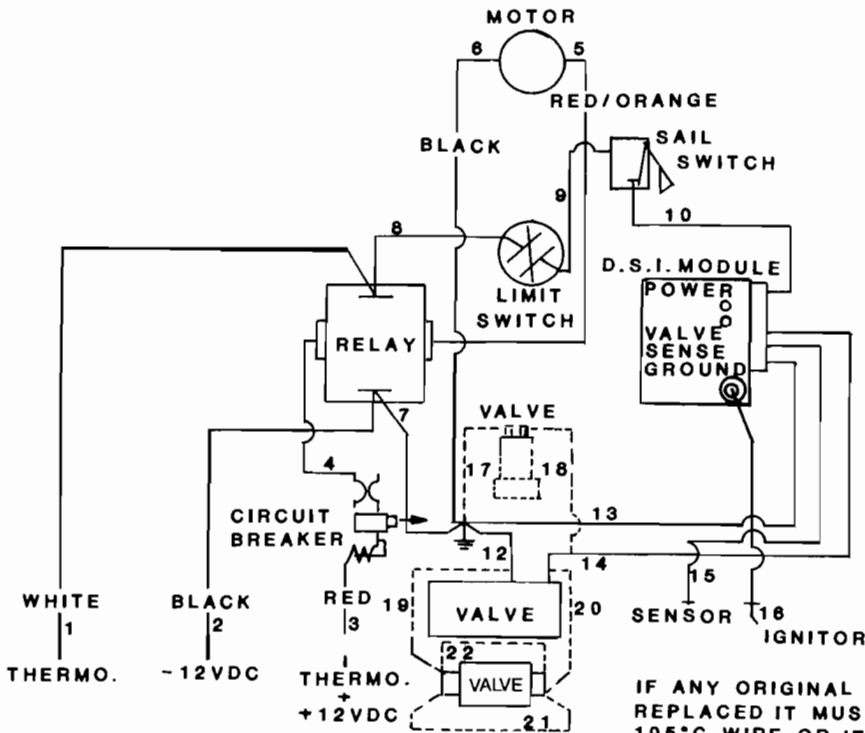

IF ANY ORIGINAL WIRE HAS TO BE REPLACED IT MUST BE REPLACED WITH 105°C WIRE OR ITS EQUIVALENT.

OPTIONAL VALVE WIRING

HF-77 SERIES PARTS SCHEMATIC

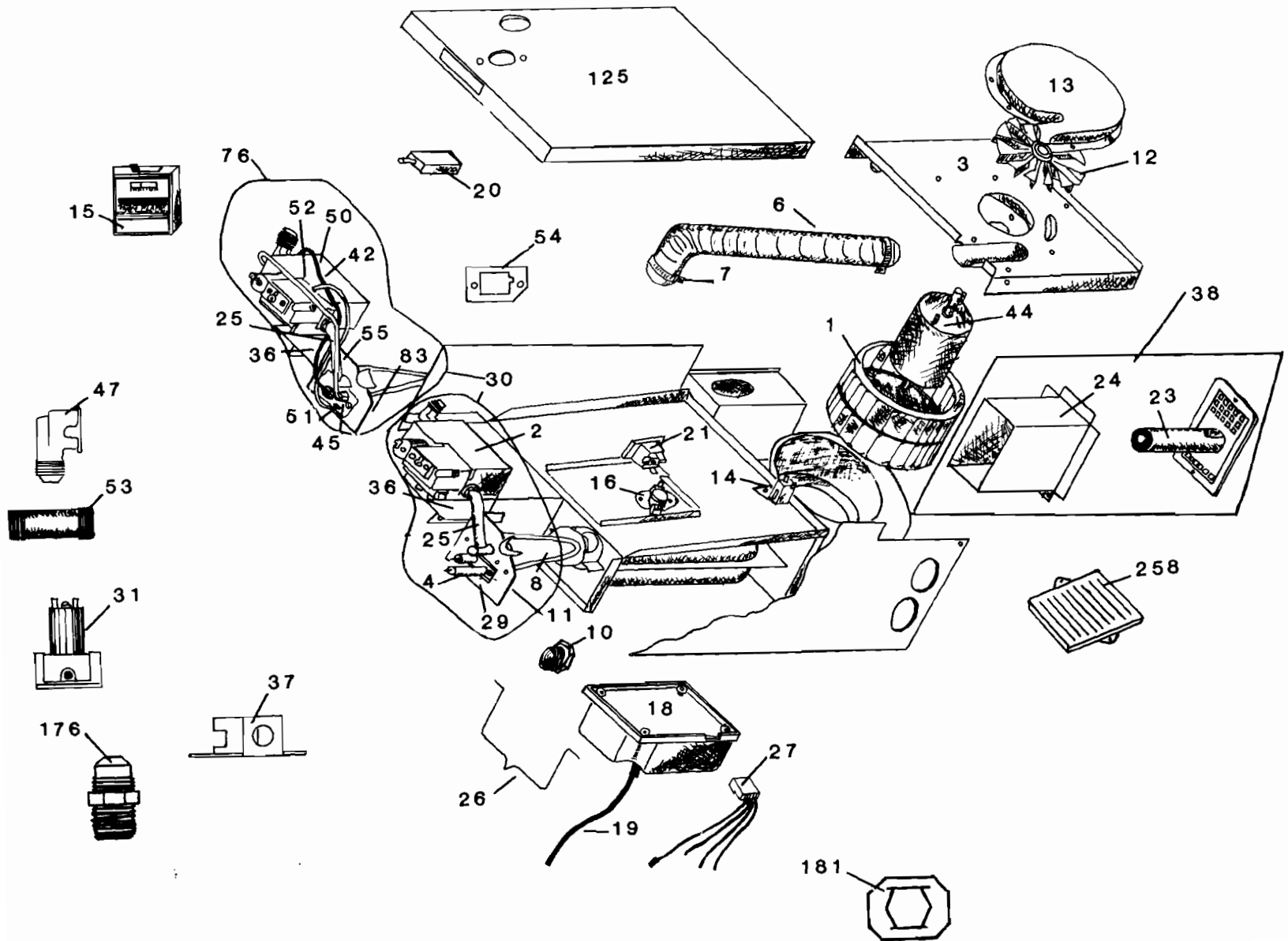

PARTS PRICE LIST

HF-77 Series DSI and Pilot Models

Schematic Number	Description	Service Center	Retail
1	Blower Wheel Fed 519-119-1	\$ 16.58	\$ 23.88
2	DSI ITT Valve RV28SBR59	62.01	90.94
3	Motor Mount Assembly	11.18	16.10
4	DSI Electrode 22-100000-466	11.98	17.25
6	Combustion Air Hose	7.99	11.51
7	Hose Clamp (one)	.57	.82
8	Burner Head Assembly	12.45	17.93
10e	#59 Orifice	.63	.91
11	DSI Burner Plate Gasket	.75	1.08
12	Combustion Air Wheel A28638	6.18	8.90
13	Combustion Blower Housing	6.12	8.81
14	Sail Switch Assembly	9.79	14.10
15	Thermostat JT2B-01	14.02	20.57
16	Limit 60T11 200740	5.54	7.98
18	DSI Board 05-152436-103	52.89	77.57
19	High Tension Lead Assembly	4.77	6.87
20a	5 Amp Circuit Breaker 44-100P10	8.38	12.07
21	Klixon Relay 60704A0-18	9.32	13.42
23a	76A Exhaust Tube Extension Assembly	8.46	12.18
23b	76B Exhaust Tube Extension Assembly	8.46	12.18
24a	76A Air Box Extension Assembly	6.44	9.27
24b	76B Air Box Extension Assembly	6.44	9.27
25	Manifold	8.00	11.52
26	DSI Wire Retainer	1.87	2.69
27a	ITT DSI Wire Harness Assembly Complete	30.00	44.00
27b	Fenwal DSI Wire Harness Assembly Complete	30.00	44.00
27c	ITT Pilot Wire Harness Assembly Complete	30.00	44.00
27d	Fenwal DSI Wire Harness DPR-10 Assembly Complete	30.00	44.00
29	DSI Burner Plate and Gasket Assembly	5.17	7.44
30a	ITT DSI Control and Burner Assembly	101.42	146.04
30b	Fenwal DSI Control and Burner Assembly	101.42	146.04
30c	ITT Pilot Control and Burner Assembly	101.42	146.04
30d	Fenwal DSI Control and Burner DPR-10 Assembly	101.42	146.04
31	Fenwal Valve SPR-10	44.72	64.40
36	Valve Mounting Bracket ITT	4.42	6.08
37	Fenwal Valve Mounting Bracket	4.42	6.08
38a	76A Vent Kit Assembly	14.87	21.41
38b	76B Vent Kit Assembly	14.87	21.41
42	ITT Pilot Valve RV28SB49	64.62	94.77
44	Motor PF-2041Q	35.39	50.96
45	ITT Pilot 26C17100TV009	6.61	9.52
47	3/8 x 3/8 Female Ell 150F-6-6	2.40	3.46
50	Jade Thermocouple TN2-14	4.70	6.77
51	Piezo Electrode	2.60	3.74
52	Piezo Sparker	10.10	14.54
53	3/8 x 2 1/2 Black Nipple	1.30	2.85
54	Pilot Gasket	.60	.86
55	Pilot Burner Plate and Gasket Assembly	6.99	10.07
76	3/8 x 3/8 Brass Male Ell 149F-6-6	1.87	2.69
83	Pilot Burner Plate Gasket	1.68	2.41
125	Casing Top	10.50	15.12
176	3/8 x 3/8 Brass Male Connector 48FX-6-6	3.47	5.00
181	Manifold Retaining Clip	.76	1.09
183a	Pilot Orifice TV009 ITT	2.74	3.95
183b	Pilot Orifice TV008 ITT	2.74	3.95
184	T-Handle	1.25	1.80
185	Door Latch	1.10	1.58
258	Blower Grille	7.62	10.97
266	3/8 x 1 Black Nipple	1.04	1.49
267	3/8 FL x 3/8 NPT 90° Brass Ell	2.40	3.46
270	Gas Ignition Board Field Tester	85.00	105.25
271	77 DPR-10 Valve Bracket Assembly	9.46	13.01

FLAT RATE LABOR SCHEDULE

HF-77 Series DSI Models

Schematic Number	Description of Replacement Part	Set Up Time	Replacement Time
1	Circulating Air Wheel	30 min.	30 min.
2	Gas Valve	30 min.	30 min.
3	Blower Plate Assembly	30 min.	30 min.
4	Electrode Assembly	30 min.	15 min.
6	Combustion Air Hose	30 min.	20 min.
7	Hose Clamps	30 min.	10 min.
8	Burner Head	30 min.	30 min.
44	Motor	30 min.	40 min.
10	Main Burner Orifice	30 min.	30 min.
11	Burner Plate Gasket	30 min.	30 min.
12	Combustion Air Wheel	30 min.	40 min.
13	Combustion Air Housing Cover		15 min.
14	Sail Switch Assembly	30 min.	20 min.
15	Thermostat	30 min.	10 min.
16	Limit Switch	30 min.	15 min.
18	Control Module DSI	30 min.	15 min.
19	High Tension Lead Assembly	30 min.	5 min.
20	Circuit Breaker	30 min.	15 min.
21	Relay	30 min.	15 min.
181	Manifold Retaining Clip	30 min.	30 min.
46	Door Assembly		10 min.
23	Vent Cap with Exhaust Tube		15 min.
24	Inlet Air Box		15 min.
25	Manifold	30 min.	30 min.
26	DSI Support Wire		10 min.
27	DSI Wiring Harness ITT/Fenwal		30 min.
	Ground Wire		10 min.
	Thermostat Wire (in furnace)		10 min.
	Relay to Ground Wire		10 min.
29	Burner Plate with Gasket and Window		20 min.
30	Burner Control Assembly		15 min.
184	T-Handle	15 min.	15 min.
185	Door Latch		5 min.

NOTE: When more than one component is defective, compute the total of both replacement times, but only one set up time.

FLAT RATE LABOR SCHEDULE HF-77 Series Pilot Models

Schematic Number	Description of Replacement Part	Set Up Time	Replacement Time
1	Circulating Air Wheel	30 min.	30 min.
42	Gas Valve ITT Pilot	30 min.	30 min.
3	Blower Plate Assembly	30 min.	30 min.
6	Combustion Air Hose	30 min.	20 min.
7	Hose Clamps	30 min.	10 min.
8	Burner Head	30 min.	30 min.
44	Motor	30 min.	40 min.
10	Main Burner Orifice	30 min.	30 min.
55	Burner Plate Gasket Pilot	30 min.	30 min.
12	Combustion Air Wheel	30 min.	40 min.
13	Combustion Air Housing Cover		15 min.
181	Manifold Retaining Clip	30 min.	30 min.
14	Sail Switch Assembly	30 min.	20 min.
15	Thermostat	30 min.	10 min.
16	Limit Switch	30 min.	15 min.
20	Circuit Breaker	30 min.	15 min.
21	Relay	30 min.	15 min.
46	Door Assembly		10 min.
23	Vent Cap with Exhaust Tube		15 min.
24	Inlet Air Box		15 min.
25	Manifold	30 min.	30 min.
30	Burner Control Assembly Pilot		15 min.
45	Pilot Assembly	30 min.	15 min.
50	Thermocouple	30 min.	15 min.
51	Piezo Electrode	30 min.	10 min.
52	Piezo Sparker	30 min.	15 min.
27	ITT Pilot Wire Harness		30 min.
54	Pilot Gasket	30 min.	15 min.
184	T-Handle	15 min.	15 min.
185	Door Latch		5 min.

NOTE: When more than one component is defective, compute the total of both replacement times, but only one set up time.

HF-77 ELECTRICAL CONNECTION
FIGURE #7

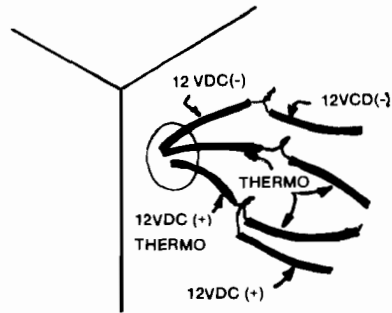

HF-77 BURNER ADJUSTMENT (DSI)
FIGURE #8

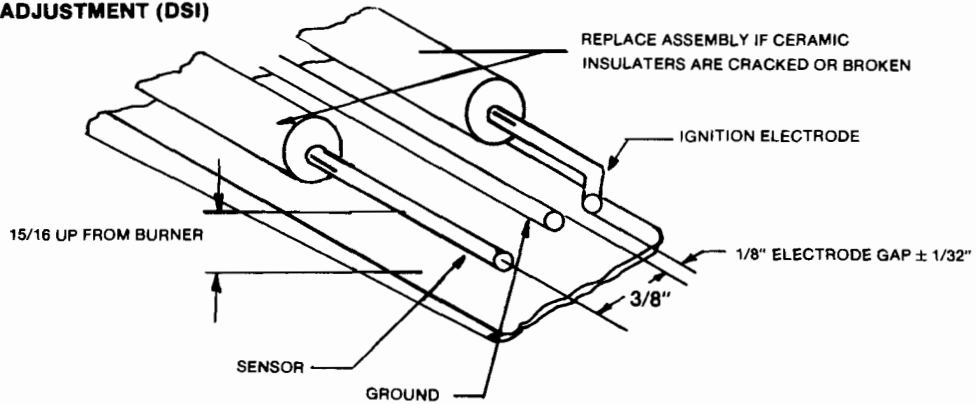

HF-77 BURNER ADJUSTMENT (PILOT)
FIGURE #9

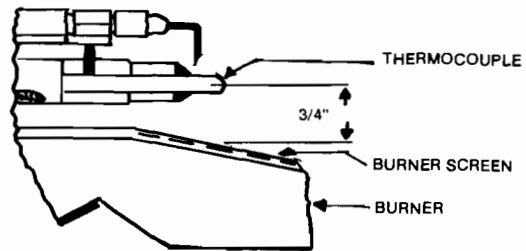

HF-77 AIR BOX EXTENSION ADJUSTMENT
FIGURE #10

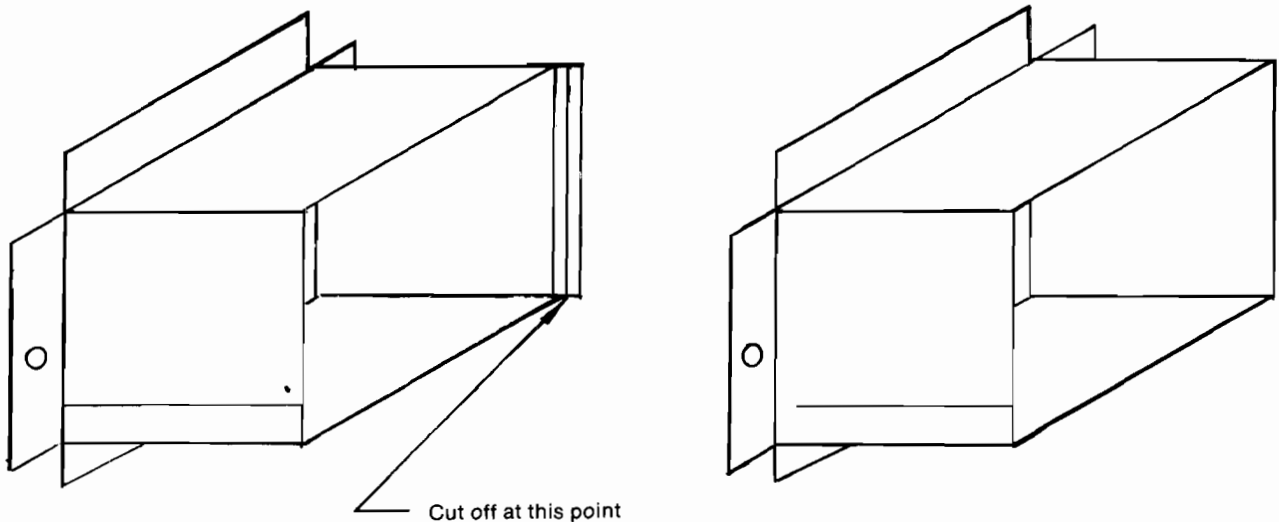

HF-77 SERIES WIRING DIAGRAM FOR (DSI) MODELS

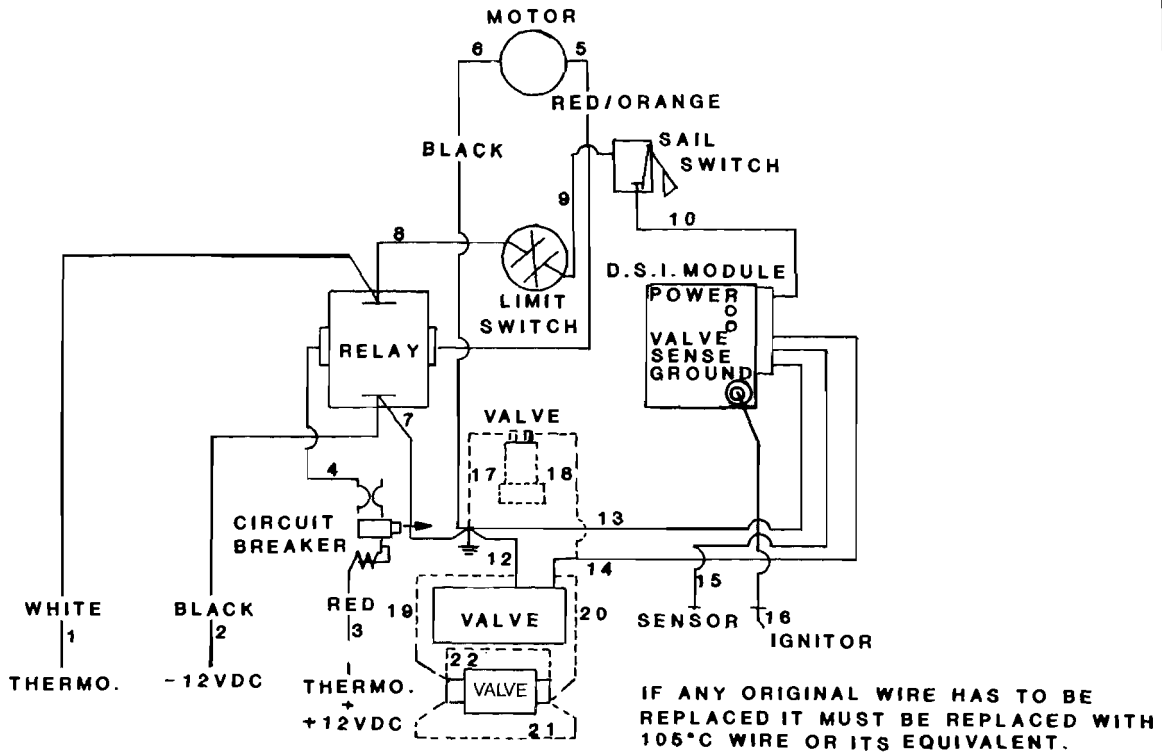

OPTIONAL VALVE WIRING

HF-77 SERIES WIRING DIAGRAM FOR (PILOT) MODELS

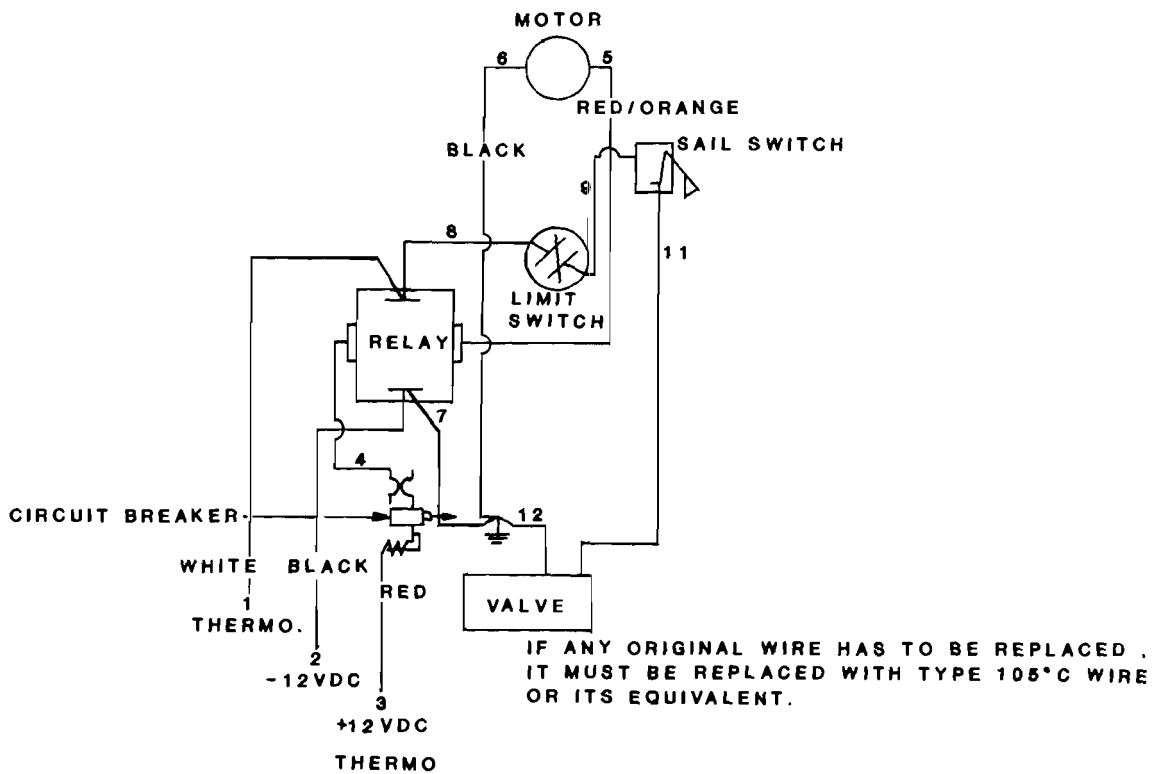

FA-79, HF-80 SERIES PARTS SCHEMATIC

28

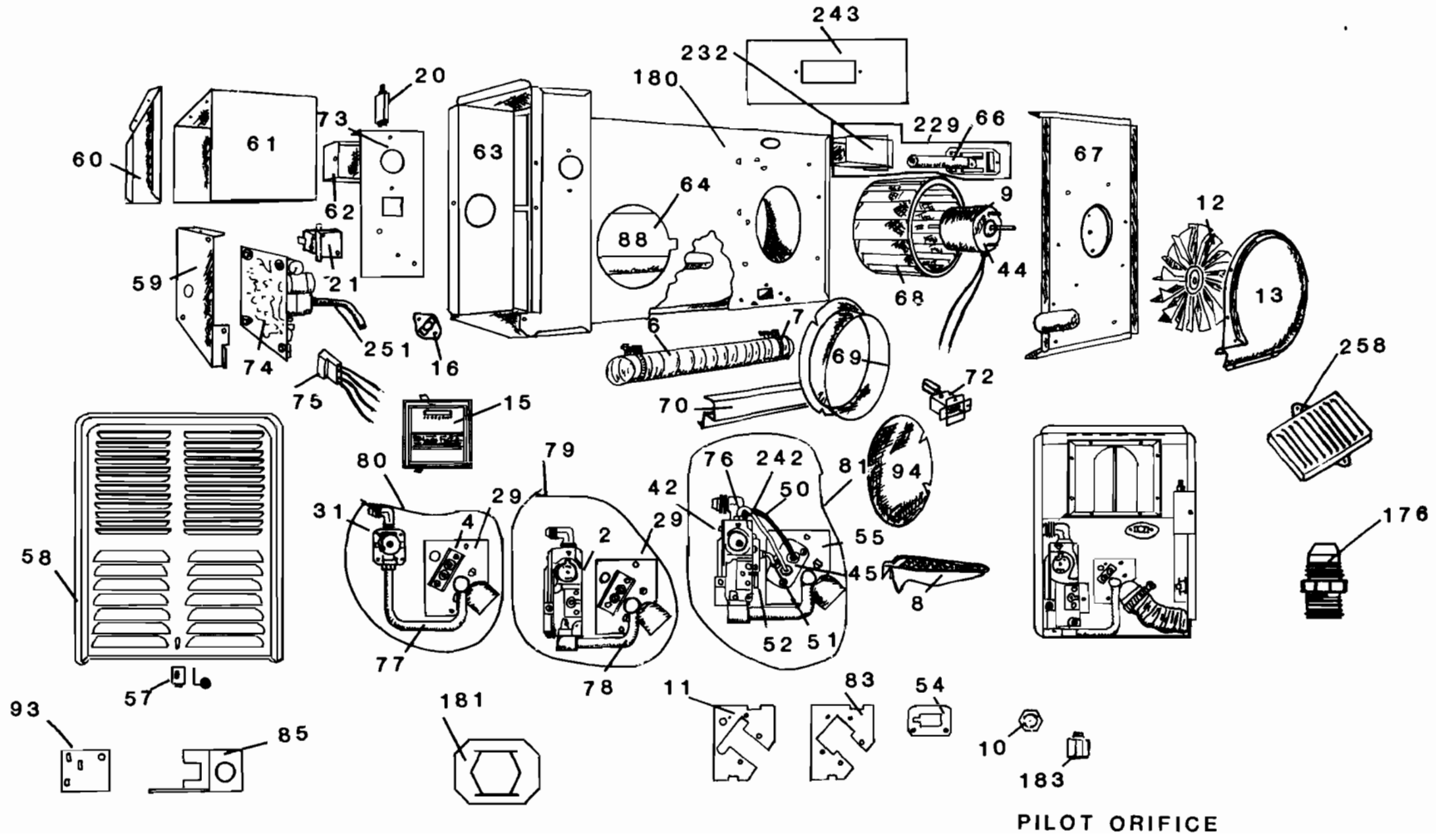

PARTS PRICE LIST

FA-79, HF-80 Series DSI and Pilot Models

Schematic Number	Description	Service Center	Retail
2	DSI ITT Valve RV28SBR59	\$ 62.01	\$ 90.94
4	Electrode 22-100000-466	11.98	17.25
6	Combustion Air Hose	7.99	11.51
7	Hose Clamp (one)	.57	.82
8	Burner Head Assembly	12.45	17.93
9	Motor PF 2040Q (FA-79 Series Only)	35.39	50.96
10c	#56 Orifice (7916)	.63	.91
10d	#1.25 M.M. Orifice (7920)	.63	.91
10e	#59 Orifice (7912, 8012)	.63	.91
11	DSI Burner Plate Gasket	.75	1.08
12	Combustion Air Wheel A28638	6.18	8.90
13	Combustion Air Housing	6.12	8.81
15	Thermostat JT2B01	14.02	20.57
16	Limit 60T11 200740	5.59	7.98
20a	5 Amp Circuit Breaker 44-100P10	8.38	12.07
21	Klixon Relay	9.32	13.42
29	DSI Burner Plate and Gasket Assembly	5.17	7.44
31	Fenwal Valve SPR-10	44.72	64.40
42	ITT Pilot Valve RV28SB49	64.62	94.77
44	Motor PF2041Q (HF-80 Series Only)	35.39	50.96
45	ITT Pilot 26C17100TV009	6.61	9.52
50	Jade Thermocouple TN2-14	4.70	6.77
51	Piezo Electrode	2.60	3.74
52	Piezo Sparker	10.10	14.54
54	Pilot Gasket	.60	.86
55	Pilot Burner Plate and Gasket Assembly	6.99	10.07
57	Roller Catch	4.22	6.08
58	Front Door Panel Assembly	12.21	17.58
59	DSI Plate	3.93	5.66
60	Front Discharge Cover Plate	3.49	5.03
61	Front Discharge Duct Assembly	10.91	15.71
62	Junction Box Cover	3.28	4.72
63	Control Box	15.97	22.99
64	Pilot Heating Element Assembly	29.31	42.20
66a	79A Exhaust Tube Extension Assembly	9.07	13.06
66b	79B Exhaust Tube Extension Assembly	9.07	13.06
66c	79C Exhaust Tube Extension Assembly	9.07	13.06
67	Blower Plate Assembly	11.18	16.10
68	Circulating Air Wheel	9.98	14.37
69	Duct Adapter	1.85	2.66
70	Hose and Wire Cover	5.54	7.98
72	Sail Switch Assembly	11.37	16.37
73	Junction Box	7.44	10.71
74a	DSI Board 05-159000-103	47.61	69.82
75a	ITT DSI Wire Harness Assembly	30.21	44.30
75b	Fenwal DSI Wire Harness Assembly	30.21	44.30
75c	ITT Pilot Wire Harness Assembly	30.21	44.30
75d	Fenwal DSI Wire Harness DPR-10 Assembly	30.21	44.30
76	3/8 x 3/8 Brass Male Ell 149F-6-6	1.87	2.69
77	Fenwal Manifold	13.94	20.07
78	ITT Manifold	11.84	17.05
79a	ITT DSI Control & Burner Assembly (7912, 8012)	90.88	133.29

PARTS PRICE LIST FA –79, HF-80 SERIES DSI AND PILOT MODELS CONTINUED

Schematic Number	Description	Service Center	Retail
79b	ITT DSI Control & Burner Assembly (7916)	\$ 90.88	\$ 133.29
79c	ITT DSI Control & Burner Assembly (7920)	99.19	142.83
80a	Fenwal DSI Control & Burner SPR-10 Assembly (7912,8012)	83.83	120.72
80b	Fenwal DSI Control & Burner SPR-10 Assembly (7916)	83.83	120.72
80c	Fenwal DSI Control & Burner SPR-10 Assembly (7920)	83.83	120.72
81a	ITT Pilot Control & Burner Assembly (7912, 8012)	113.17	162.96
81b	ITT Pilot Control & Burner Assembly (7916)	113.17	162.96
81c	ITT Pilot Control & Burner Assembly (7920)	113.17	162.96
83	Pilot Burner Plate Gasket	1.68	2.41
85	Fenwal Valve Bracket	.84	1.21
88	DSI Heating Element Assembly	32.93	47.42
93	ITT Valve Bracket	3.01	4.33
94	Duct Cover Plate	1.97	2.83
176	3/8 x 3/8 Brass Male Connector 48F-6-6	3.47	5.00
180	Casing Assembly	41.14	59.24
181	Manifold Retaining Clip	.76	1.09
183a	Pilot Orifice TV009	2.74	3.95
183b	Pilot Orifice TV008	2.74	3.95
229a	79A Vent Kit Assembly	15.36	22.12
229b	79B Vent Kit Assembly	15.36	22.12
229c	79C Vent Kit Assembly	15.36	22.12
232a	79A Air Box Extension Assembly	6.65	9.59
232b	79B Air Box Extension Assembly	6.65	9.59
232c	79C Air Box Extension Assembly	6.65	9.59
242	Pilot Tube Assembly	9.99	14.39
243	Vent Support Bracket	1.60	2.34
251	High Tension Lead Wire Assembly	4.77	6.87
258	Blower Grille	7.62	10.97
261	1/4" Pilot Tube Breakaway Fitting	1.70	2.96
263	79/80 DPR-10 Valve Bracket Assembly	8.84	12.16
265	Fenwal DPR-10 Valve	50.27	73.74
266	3/8" x 1 Black Nipple Pipe	1.04	1.49
267	3/8 FL x 3/8 FNPT 90° Brass Ell	2.40	3.46
268a	Fenwal DSI Control & Burner DPR-10 Assembly (7920)	99.19	142.83
268b	Fenwal DSI Control & Burner DPR-10 Assembly (7916)	99.19	142.83
269c	Fenwal DSI Control & Burner DPR-10 Assembly (7912/8012)	99.19	142.83
270	Gas Ignition Board Field Tester	85.00	105.25

FLAT RATE LABOR SCHEDULE

FA-79 and HF-80 Series D.S.I. & Pilot Models

Schematic Number	Description of Replacement Part	Set Up Time	Replacement Time
57	Roller Catch		10 min.
58	Door		5 min.
60	Front Discharge Cover Plate		10 min.
59	Electrical Plate		15 min.
61	Front Discharge Duct Assembly		15 min.
62	Junction Box Cover	30 min.	15 min.
20	Circuit Breaker	30 min.	15 min.
180	Furnace Casing		60 min.
64, 88	Heating Element Assembly	30 min.	45 min.
232	Air Box Extension		10 min.
66	Vent Cap Assembly		10 min.
9, 44	Motor	30 min.	40 min.
67	Blower Plate		40 min.
12	Combustion Air Wheel	30 min.	30 min.
13	Combustion Air Housing		20 min.
68	Circulating Air Wheel	30 min.	30 min.
69	Duct Adapter		10 min.
7	Hose Clamp	30 min.	10 min.
6	Air Hose	30 min.	20 min.
70	Wire and Hose Cover		10 min.
10	Orifice Main Burner	30 min.	30 min.
72	Sail Switch Assembly	30 min.	30 min.
15	Thermostat	30 min.	10 min.
16	Limit Switch	30 min.	15 min.
73	Junction Box		20 min.
21	Relay	30 min.	15 min.
74	DSI Board	30 min.	15 min.
75	DSI Wire Harness ITT/Fenwal	30 min.	20 min.
261	Brass Breakaway Fitting		15 min.
31	Valve Fenwal	30 min.	30 min.
4	Electrode	30 min.	15 min.
29	Burner Plate with Gasket DSI		15 min.
77	Manifold (Fenwal)	30 min.	30 min.
2	Valve (ITT/DSI)	30 min.	30 min.
78	Manifold (ITT)	30 min.	30 min.
55	Burner Plate with Gasket Pilot		30 min.
79	Burner Assembly (ITT/DSI)	30 min.	20 min.
42	Valve (ITT/PILOT)	30 min.	30 min.
80,268	Burner Assembly (Fenwal)	30 min.	20 min.
50	Thermocouple	30 min.	15 min.
83	Pilot Orifice	30 min.	15 min.
81	Burner Assembly (ITT/Pilot)	30 min.	20 min.
8	Burner Head	30 min.	15 min.
11	Burner Plate Gasket (DSI)		30 min.
82	Burner Plate Gasket (Pilot)		30 min.
54	Pilot Gasket	30 min.	15 min.
85	Control Mounting Bracket (Fenwal)		20 min.
93	Control Mounting Bracket (ITT)		20 min.
94	Duct Cover Plate		10 min.

NOTE: When more than one component is defective, compute the total of both replacement times, but only one set up time.

FA-79, HF-80 ELECTRICAL CONNECTIONS
FIGURE #11

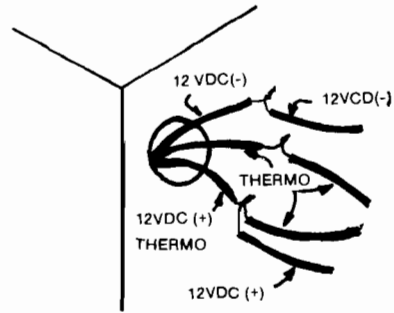

FA-79, HF-80 BURNER ADJUSTMENT (DSI)
FIGURE #12

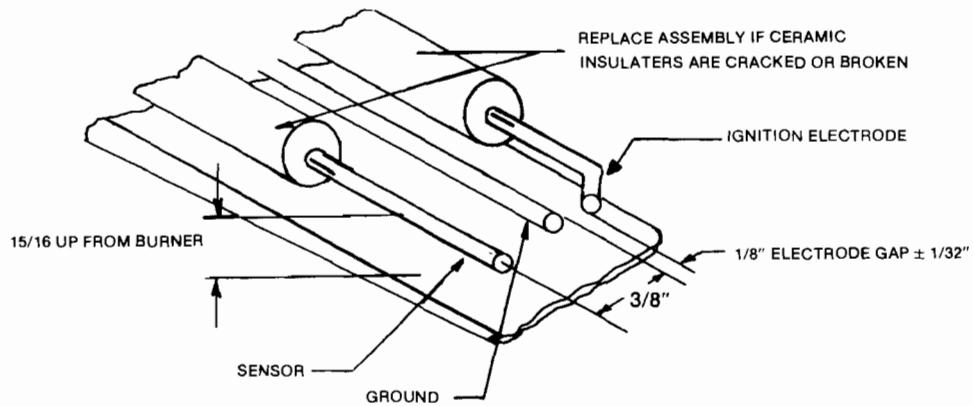

FA-79, HF-80 BURNER ADJUSTMENT (PILOT)
FIGURE #13

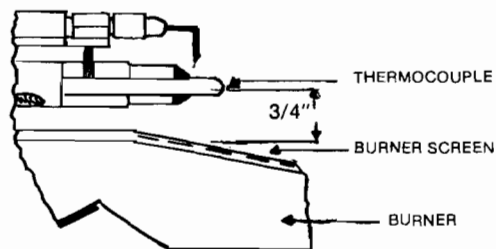

FA-79, HF-80 SERIES WIRING DIAGRAM FOR (DSI) MODELS

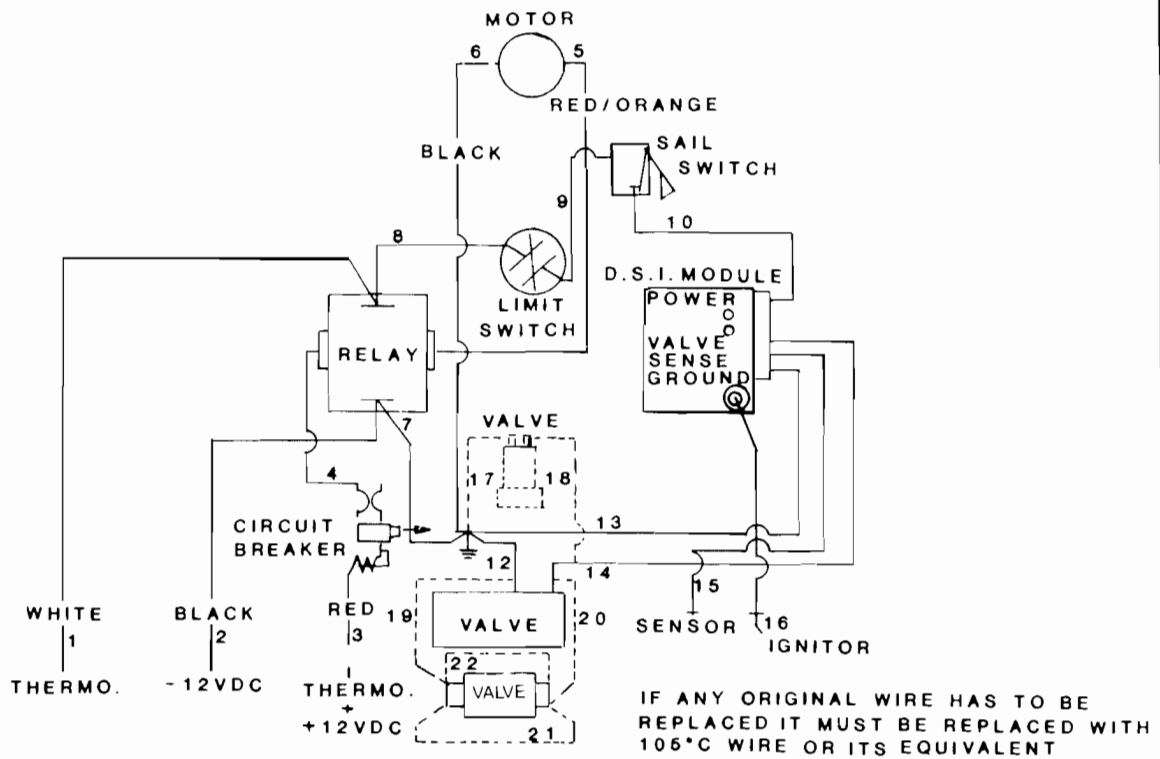

OPTIONAL VALVE WIRING

FA-79, HF-80 SERIES WIRING DIAGRAM FOR (PILOT) MODELS

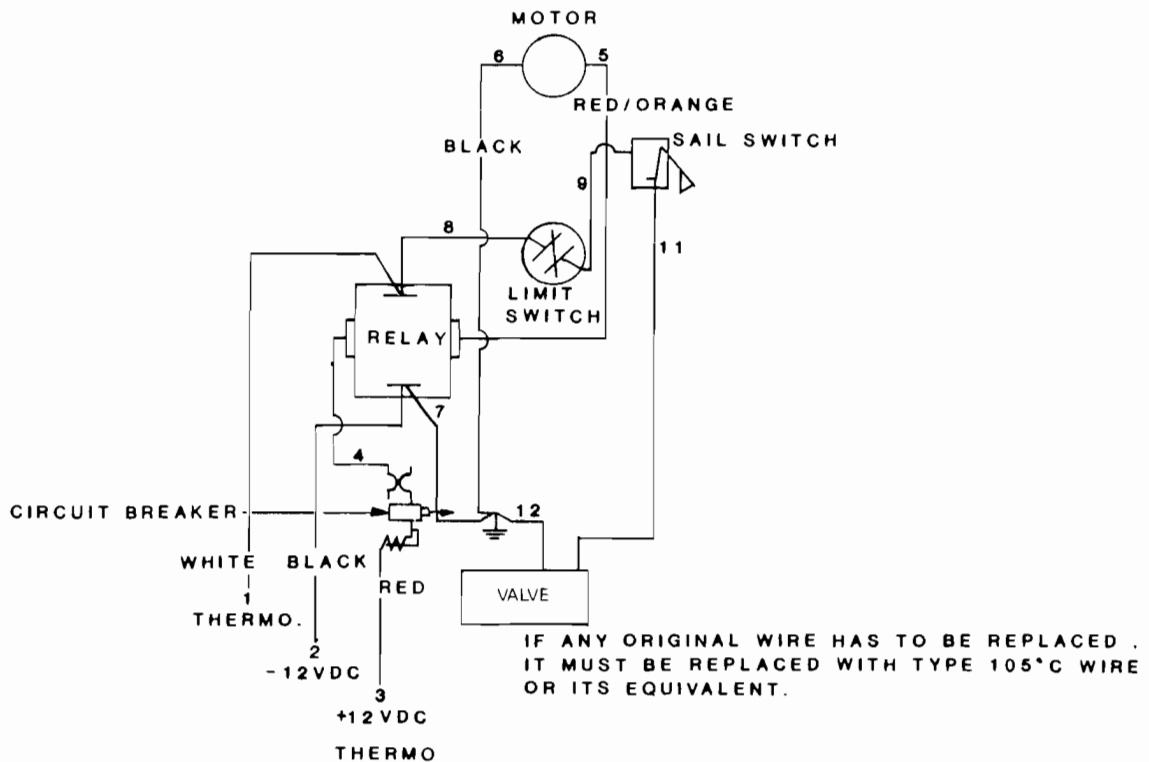

FA-78, AC-82, DC-82 SERIES PARTS SCHEMATIC

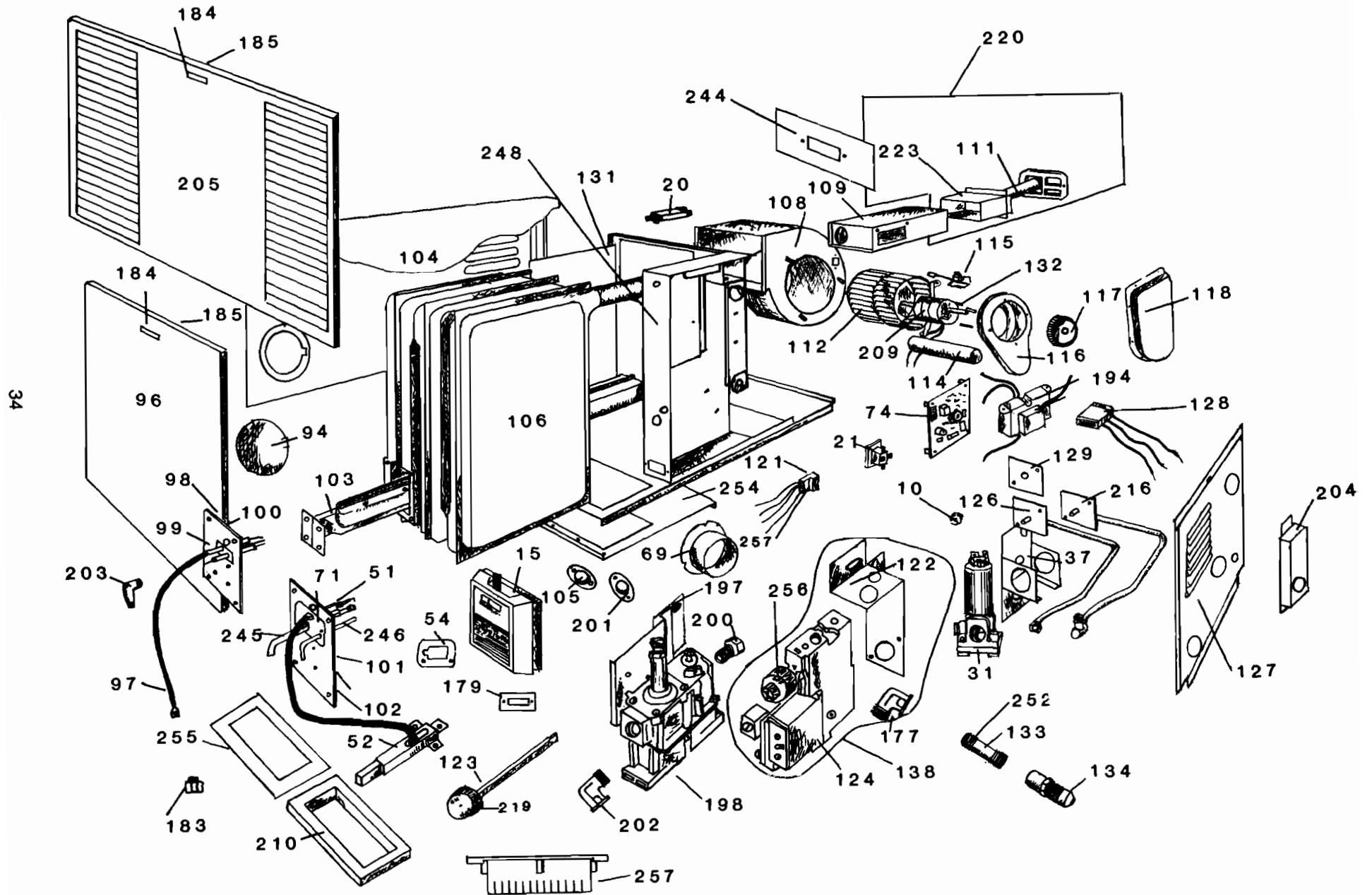

PARTS PRICE LIST

FA-78, AC-82, DC-82 Series DSI and Pilot Models

Schematic Number	Description	Service Center	Retail
10a	#50 Orifice (8241 Propane)	\$.63	\$.91
10b	#36 Orifice (8241 Natural)	.63	.91
10f	#52 Orifice (7832, 8232 Propane)	.63	.91
10g	#54 Orifice (7825, 8225 Propane)	.63	.91
10i	#40 Orifice (8235 Natural)	.63	.91
10j	#51 Orifice (8235 Propane)	.63	.91
15	Thermostat	14.02	20.57
20a	5 Amp Circuit Breaker (AC units)	8.38	12.07
20b	7 Amp Circuit Breaker (DC units)	8.38	12.07
21	Klixon Relay	9.32	13.42
31	Fenwal Valve SPR-10	44.72	64.40
37	Fenwal Valve Bracket	4.42	6.08
51	Piezo Electrode	2.60	3.24
52	Piezo Sparker	10.10	14.54
54	Pilot Gasket	.60	.86
69	Duct Adapter	1.85	2.66
71	Jade Pilot Assembly	21.10	30.95
74a	DSI Board 05-159000-103 (12 volt)	47.61	69.82
74b	DSI Board 05-169003-103 (24 VAC)	47.61	69.82
94	Duct Cover Plates	1.97	2.83
96	Front Door Assembly	15.49	22.30
97	High Tension Lead Wire Assembly	6.26	9.01
98	DSI Burner Plate & Gasket Assembly	2.78	4.00
99	Fenwal Electrode 22-100000-471	10.65	15.62
100	DSI Burner Plate Gasket	.86	1.24
101	Pilot Burner Plate & Gasket Assembly	3.69	5.31
102	Pilot Burner Plate Gasket	.86	1.24
103a	Burner (7825, 32, 8225, 32)	25.50	26.72
103b	Burner (8235, 8241)	25.50	26.72
104	Casing Assembly	26.79	38.58
105	Limit Switch	5.54	7.98
106a	Heating Element Assembly (78 Series, 8225, 8232)	60.54	87.17
106b	Heating Element Assembly (8235, 8241)	61.02	89.50
108	Blower Housing Assembly	12.21	17.72
109	Combustion Air Box Assembly	8.50	12.24
111a	82A & B Exhaust Tube Extension Assembly (78 series, 8225, 8232)	9.63	13.86
111b	82C Exhaust Tube Extension Assembly (78 series 8225, 8232)	9.63	13.86
111c	82D & E Exhaust Tube Extension Assembly (8235, 8241)	9.63	13.86
111d	82F Exhaust Tube Extension Assembly (8235, 8241)	9.63	13.86
112	Circulating Air Wheel	16.89	24.32
114	Combustion Air Tube	5.54	7.98
115	Sail Switch Assembly	10.47	15.08
116	Combustion Air Housing Assembly	9.86	14.19
117	Combustion Air Wheel	10.47	15.08
118	Air Drop Cover Assembly	7.05	10.15
121a	DSI ITT Wire Harness Assembly (DC)	34.20	50.16
121b	DSI Fenwal Wire Harness Assembly (DC)	34.20	50.16
121c	DSI Johnson Wire Harness Assembly (DC)	34.20	50.16
121d	DSI Johnson Wire Harness Assembly (AC)	34.20	50.16
121e	Pilot ITT Wire Harness Assembly (DC)	34.20	50.16
121f	DSI Fenwal DPR-10 Wire Harness Assembly (DC)	34.20	50.16
122	ITT Valve Bracket	4.22	6.08
123a	Valve Knob Extension Rod ITT	5.47	8.03
123b	Valve Knob Extension Rod Fenwal	5.47	8.03
124a	DSI ITT Value RV28SBR68	62.05	91.01
124b	Pilot ITT Valve RV28SB69	62.05	91.01

PARTS PRICE LIST FA—78, AC-82, DC-82 SERIES DSI AND PILOT MODELS CONTINUED

Schematic Number	Description	Service Center	Retail
126	ITT Mainfold	\$ 14.76	\$ 21.25
127a	Louver Door Assembly (AC)	5.54	7.98
127b	Louver Door Assembly (DC/DSI)	5.54	7.98
127c	Louver Door Assembly (DC/Pilot)	5.54	7.98
128a	Field Electrical Hookup Assembly (DC)	9.82	14.14
128b	Field Electrical Hookup Assembly (AC)	9.82	14.14
129	Manifold Door Gasket	.76	1.09
131	Plenum Assembly	22.50	32.40
132a	78 Blower Motor PE2627Q	46.55	67.03
132b	AC82 Motor JA25065N	46.92	68.81
132c	DC82 Motor PF-23129Q	46.55	67.03
133	1/4 x 2" Black Nipple	1.04	1.49
134	3/8 x 1/4 Brass Female Connector 46F-6-4	1.87	2.69
138a	ITT DSI Valve Assembly	88.92	128.04
138b	ITT Pilot Valve Assembly	88.92	128.04
177	1/4 x 1/43 Brass 90° Street Ell 1202P-4-4	3.66	5.27
179	DSI Electrode Gasket	.76	1.04
183c	Pilot Orifice TV010 Jade	2.74	3.95
184	T-handle	1.25	1.80
185	Door Latch	1.10	1.58
194a	DC 12 Volt Converter Assembly (old style AC unit only)	56.67	81.60
194b	AC 24 Volt Transformer	56.67	81.60
197	Johnson Valve Bracket Assembly	4.22	6.07
198a	DSI Johnson Valve G54BDG-2 (Nat'l/Propane)	50.27	73.74
198b	DSI Johnson Valve G54BCG-2 (Propane)	49.01	70.57
200	1/2 x 3/8 Male Connector 48 IFHD-8-6	3.24	4.75
201	Limit Switch Face Plate	1.81	2.66
202	3/8 x 3/8 Brass 90° Street Ell 2202P-6-6	4.38	6.42
203	90° Spark Plug Boot	1.25	1.80
204	AC Junction Box Cover	5.07	7.43
205	Self Trim Door Assembly	27.96	40.99
209a	Motor Bracket Assembly (78 Motors)	5.66	8.15
209b	Motor Bracket Assembly (AC & DC Motors)	5.66	8.15
210	Bottom Discharge Gasket	1.65	2.37
216	Fenwal Manifold	17.36	24.99
219a	Valve Rod Knob ITT	2.43	3.49
219b	Valve Rod Knob Fenwal	2.43	3.49
220a	82A Vent Kit Assembly (78 Series, 8225, 8232)	15.36	22.12
220b	82B Vent Kit Assembly (78 Series, 8225, 8232)	15.36	22.12
220c	82C Vent Kit Assembly (78 Series, 8225, 8232)	15.36	22.12
220d	82D Vent Kit Assembly	15.36	22.12
220e	82E Vent Kit Assembly	15.36	22.12
220f	82F Vent Kit Assembly	15.36	22.12
223a	82A & D Air Box Extension Assembly (78)	6.65	9.57
223b	82B & E Air Box Extension Assembly (78)	6.65	9.57
223c	82C & F Air Box Extension Assembly (78)	6.65	9.57
244	Vent Support Bracket	2.54	3.66
245	82 Pilot Tube Assembly	12.12	17.45
246	82 Thermocouple	5.28	7.74
248	Control Box Assembly	22.26	32.05
252	1/4 x 1½ Black Nipple	1.04	1.49
254	Slide Plate	3.10	4.46
255	Bottom Plenum Plate	5.23	7.53
256a	ITT Valve DSI Knob	2.40	3.52
256b	ITT Valve Pilot Knob	2.40	3.52
257	Bottom Discharge Adapter		
264	82 DPR-10 Valve Bracket Assembly	8.84	12.16
265	Fenwal DPR-10 Valve	50.27	73.74
270	Gas Ignition Board Field Tester Fenwal	85.00	105.25

FLAT RATE LABOR SCHEDULE

FA-78, AC-82, DC-82 Series DSI and Pilot Models

Schematic Number	Description of Replacement Part	Set Up Time	Replacement Time
96	Casing Door Assembly		10 min.
97	High Tension Lead Assembly	30 min.	20 min.
98	Burner Plate Gasket (DSI)		15 min.
99	Electrode Assembly	30 min.	15 min.
100	Burner Plate Gasket (DSI)		30 min.
101	Burner Plate Pilot & Gasket	30 min.	15 min.
71	Pilot Assembly	30 min.	15 min.
102	Burner Plate Pilot and Gasket		30 min.
52	Piezo Sparker	30 min.	15 min.
103	Burner	30 min.	20 min.
104	Casing Sides and Top		30 min.
15	Thermostat	30 min.	10 min.
105	Limit Switch	30 min.	15 min.
106	Heating Element Assembly	30 min.	60 min.
108	Circulating Blower Assembly		30 min.
109	Combustion Air Box Assembly		20 min.
223	Combustion Air Box Extension		15 min.
111	Vent Cap Assembly	30 min.	10 min.
112	Circulating Air Wheel	30 min.	30 min.
132	Motor	30 min.	40 min.
114	Combustion Air Tube	30 min.	20 min.
115	Sail Switch Assembly	30 min.	20 min.
116	Combustion Air Housing Assembly		30 min.
117	Combustion Air Wheel	30 min.	20 min.
118	Air Drop Assembly		20 min.
121	Pilot Wire Harness	30 min.	20 min.
74	DSI Board	30 min.	20 min.
21	Relay	30 min.	20 min.
121	DSI Wire Harness		20 min.
122	Control Mounting Bracket ITT	30 min.	25 min.
69	Duct Adapters		10 min.
123	Control Valve Knob Extension		10 min.
124,198,265	Valve ITT/Fenwal DSI		30 min.
124	Valve ITT/Pilot	30 min.	30 min.
10	Orifice Main Burner	30 min.	30 min.
126	Manifold (ITT)	30 min.	30 min.
127	Louver Door		10 min.
128	Field Electrical Hookup		15 min.
128	Manifold Gasket	30 min.	20 min.
131	Plenum Assembly		60 min.
133	1/4 x 2" Black Nipple		15 min.
134	3/8 x 1/4 Brass Female Connector 46F-6-4		15 min.
177	1/4 x 1/4 Brass 90° Street Ell 1202-P-44		15 min.
138	Valve Assembly (DSI/ITT)	20 min.	30 min.
138	Valve Assembly (Pilot/ITT)		30 min.
54	Pilot Gasket	30 min.	15 min.
179	DSI Electrode Gasket		15 min.
184	T-Handle		15 min.
185	Door Latch	15 min.	5 min.

NOTE: When more than one component is defective, compute the total of both replacement times, but only one set up time.

SERVICE GUIDE

FA-78, AC-82, DC-82 Series Furnaces

Sequence of Normal Operation

Each step in this operation must be completed in the sequence listed below before the next function will occur. To properly diagnose a malfunction and correct it, it must be determined at what step the operation of the furnace failed.

1. When the temperature drops to the thermostat set temperature, the wall thermostat contacts close.
2. Current is supplied through a fan relay coil which is energized, after a 15 to 20 second delay. Completing the circuit to the blower motor.
3. The motor starts, turning the combustion and circulating air blower wheels.
4. When the blower reaches the necessary RPMs to close the air operated sail switch (approximately 1 to 2 seconds), current is supplied through a temperature limit switch to the D.S.I. control board on DSI units and "ON" pilot models to the valve.
5. When energized, the DSI module has a built-in 15 second delay to purge the combustion chamber.
6. The D.S.I. module supplies a high voltage spark through the high tension lead to the igniter.
7. At the same time current is supplied from the DSI module to the valve. Valve then opens.
8. The burner ignites.
9. The sensor signals the presence of a flame and the spark stops. (If flame is not established within 7 seconds, the system closes the gas valve and locks out. The thermostat must be reset to try for relight.)
10. The gas valve closes when either the thermostat, or the limit switch contacts open.
11. The blower motor stops when the time relay opens.

GENERAL

Most electrical components, except the motor, and the sail switch can be checked or replaced while the furnace is installed. Do not use a battery charger to power or test the furnace, this could damage the control module or the thermostat. All testing and repair should be done by qualified personnel only. Do not use a screwdriver or any other metal tool to touch any part of the electrode assembly while the furnace is running. Do not attempt to operate the furnace with the high tension lead wire disconnected or the electrode assembly removed from the burner plate.

AC series units prior to Terra Lab Serial Number 1005026 operate the same except, the motors are 110 volts A.C. and the rest of the system is powered through a 12 volt DC convertor. See the wiring diagrams in this section. All units after Terra Lab Series Number 1005026 operate the same except all components have been changed to a 24 volt A.C. circuit system powered by a 24 VAC transformer. See wiring diagrams in this section.

A. Thermostat is calling for heat, but blower does not run

1. Check for 12 volts DC or 120 volts AC at the furnace connection. Correct power source if found to be below 10.5 volts or above 14.5 volts D.C. or if below 105 volts or above 135 volts A.C.
2. Check all wiring for correct polarity, (refer to wiring diagram). Loose connections and possible shorts and open circuits. Check the field hook-ups at the plastic connectors. On 12 VDC units the (+) positive wire red in color is located on the round side of the plug. The (-) negative wire black in color, should be in the middle and the white or blue thermostat lead should be on the square side of the connector, see figure 14. The AC units the green (-) ground wire should be on the round side and the square side should have a red 110 volt wire and the center should be a white 110 volt wire and the two blue wires below the connector are for the wall thermostat, see figure 15.
3. Check the wall thermostat and wiring for continuity.

4. Check for voltage at the orange or red lead out to the relay. (On 110 VAC units check for 110 volts) if "0" volts replace relay.
5. If there is power to the motor leads and the blower wheel is not obstructed and all wiring is good. Replace the motor.

B. Blower is noisy

1. Check for debris in wheel or damage or looseness. Remove debris and tighten the wheel properly. *if damaged replace.*
2. Check for excessive voltage, and correct.
3. Check polarity. If reversed, motor will whine and run backwards, air delivery may be too low to close the sail switch.
4. The wheel may be hitting the housing. Adjust the wheel with an Allen wrench.

C. Blower runs but burner does not light

1. Check for possible air in gas lines. Reset thermostat and cycle the furnace several times.
2. Check gas supply pressure. Make certain, 11" W.C. pressure is at the furnace on all propane models. (On models using natural gas set pressure for 7" W.C.) Check to see if valve knob is in the "ON" position. All appliances must be running during gas pressure check.
3. Check wiring for polarity and continuity to the DSI module.
4. Check for power to and from the sail switch. Check for power to and from the limit switch. If power is only on one side of the switches replace the switch. If both check good, proceed to Step 5.
5. Observe if the sail switch moves upwards (to close contacts). When the blower reaches full RPM, if the sail switch is immobile or voltage is not present at both terminals when closed, replace the sail switch.
6. Check for voltage at the power terminals on the DSI control module (refer to wiring diagram). If "0" volts check wire from sail switch for continuity.
7. If sparking is audible the approximately 15 seconds after the blower starts, but no ignition, check the high tension wire for continuity, grounding and good connections. Repair if defective.
8. Make sure the electrode is not grounding, the gap is 1/8" and, the ceramic insulator is not cracked. Broken or sooted. Adjust, clean or replace. See figure 16.
9. If sparking is not audible, remove the DSI module and observe if the neon bulb on circuit board is flashing during the trial for ignition period. Remove the white plastic connector from the circuit board. Clean the board terminals with a soft, rubber eraser. Check the terminals in the plastic connector for good contact. If bulb still does not flash, replace the DSI control module.
10. Check for voltage at the gas valve during the trial for ignition period. If "0" volts and connections are good, and wires have continuity, replace the DSI module.
11. If the valve does not open with voltage to the valve, replace the valve.
12. With electrode sparking, valve opening, but the burner will not light. Check the gas supply, vent and air tube installation. Check air tube from combustion blower. Check voltage to the furnace. Check the electrode alignment as shown in figure 16. Check main burner orifice for debris.

D. Burner ignites but shuts off

1. Check the sensor adjustments as shown in figure 16.
2. Check the electrode assembly mounting screws and all the ground terminals for tightness.
3. Check continuity through the DSI module to the sensor lead.
4. The flame detector circuit uses the ionized gas flame to conduct the flame safe signal. To check, shut off the power, remove the lead from the sensor and insert a 0-50 micro amp meter in series with the sensor and the sensor wire and "NEGATIVE" terminal to sensor electrode. Energize the igniter. The reading should be above 5 micro amps or higher. (If "0", reverse the leads .) Adjust or replace the electrode if reading is below 5 micro amps.

5. If reading is 5 micro amps or above and lockout still occurs, replace the DSI module.

E. Main burner will not shut off

1. Make sure the thermostat and the relay contacts are open.
2. Check voltage at the valve terminals. There should be "0" volts.
3. Disconnect leads from the valve. If the valve does not shut off, replace the valve.

F. Continuous sparking

1. Continuous sparking is caused by separations in the high tension lead wire or poor terminal connections. Repair or replace.

G. Erratic blower and/or thermostat operation

1. Check all wiring to the furnace.
2. Check for shorts in the main wiring.
3. Disconnect leads to the gas valve, if the furnace operates properly with leads removed. Replace the gas valve.

H. Repeated control module failures

1. Check to be sure that the igniter or the high tension lead is not sparking to the sensor or the lead wire.
2. Check the voltage from the coach converter. If over 14½ VDC output is present, adjust or replace the converter.

I. Humming noise on AC series.

1. Caused by the converter used to power the controls. The humming is normal.

**FA-78, DC-82 SERIES WIRING
FIGURE #14**

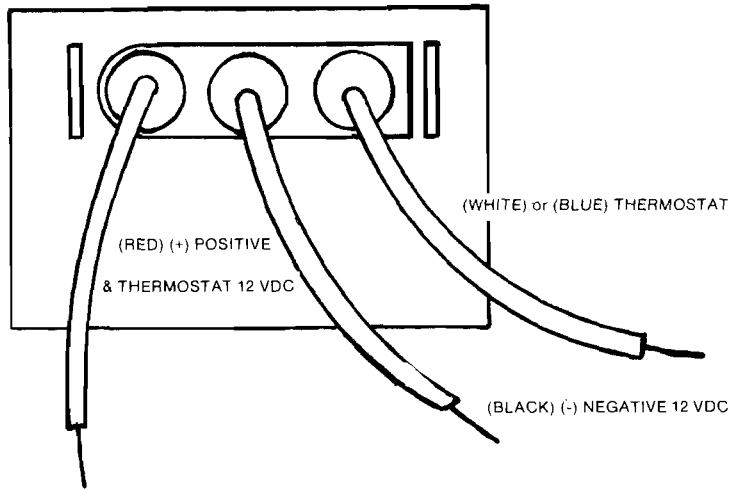

**AC-82 SERIES WIRING
FIGURE #15**

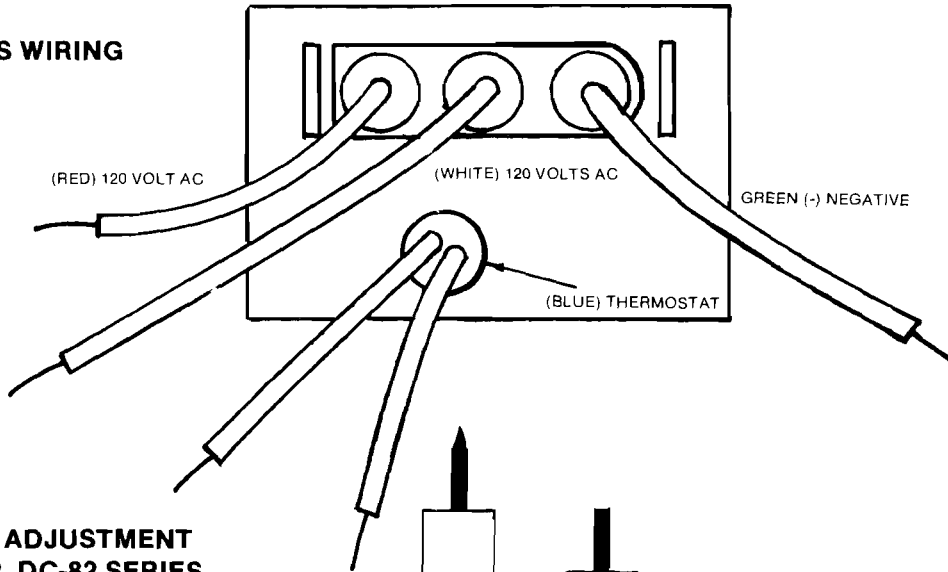

**ELECTRODE ADJUSTMENT
FA-78, AC-82, DC-82 SERIES
FIGURE #16**

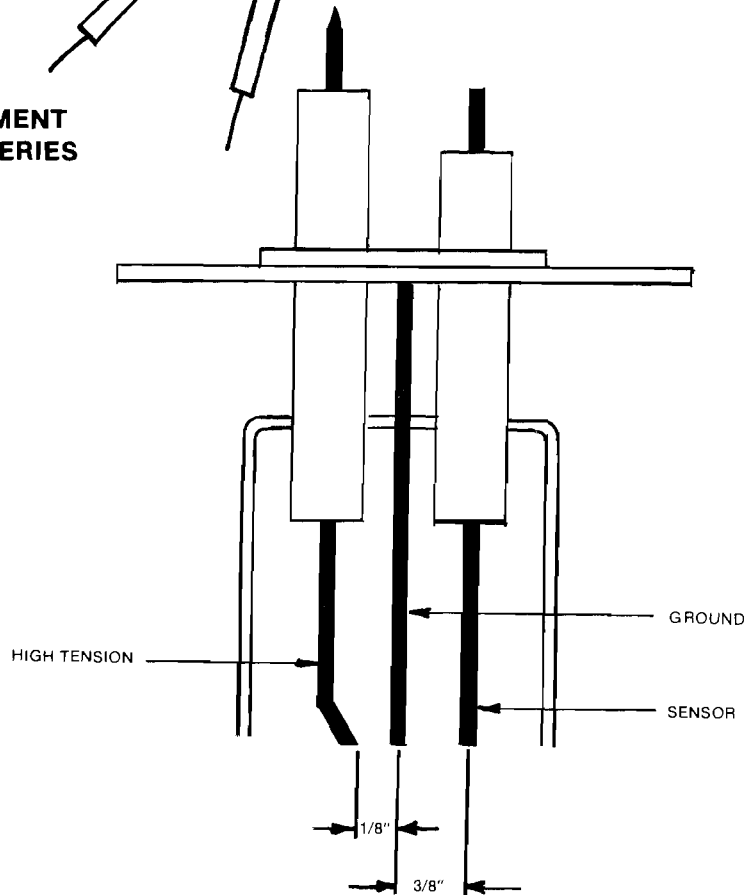

FA-78, DC-82 SERIES WIRING DIAGRAM FOR (DSI) MODELS

IF ANY ORIGINAL WIRE HAS TO BE REPLACED . IT MUST BE REPLACED WITH TYPE 105°C WIRE OR ITS EQUIVALENT.

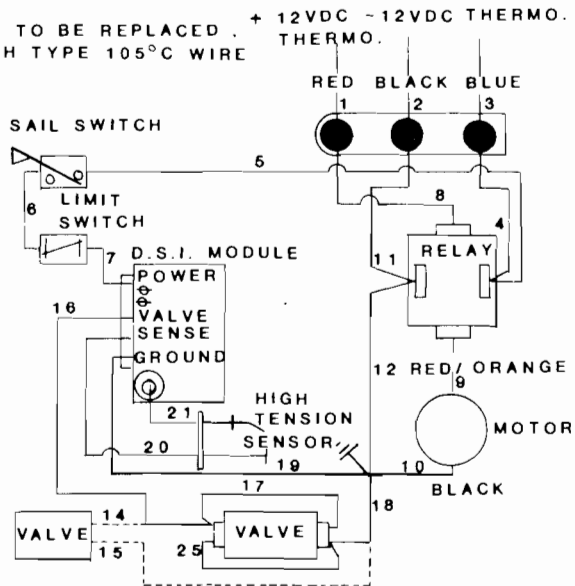

MAXIMUM IN LINE FUSE SIZE - 15 AMP.

OPTIONAL VALVE WIRING

FA-78, DC-82 SERIES WIRING DIAGRAMS FOR (DSI) MODELS (WITH CIRCUIT BREAKER)

IF ANY ORIGINAL WIRE HAS TO BE REPLACED, IT MUST BE REPLACED WITH TYPE 105°C WIRE OR ITS EQUIVALENT.

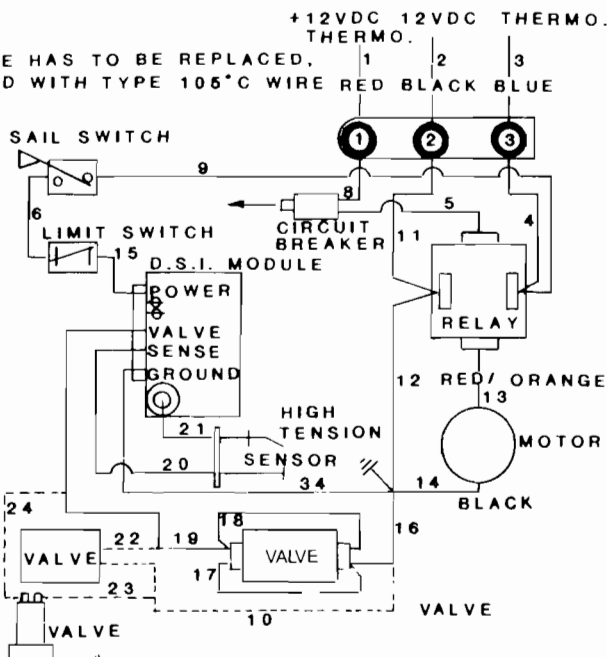

MAXIMUM SUPPLY LINE FUSE SIZE - 15 AMP.

OPTIONAL VALVE WIRING

AC-82 SERIES WIRING DIAGRAMS FOR (DSI) MODELS (24 VAC SYSTEM)

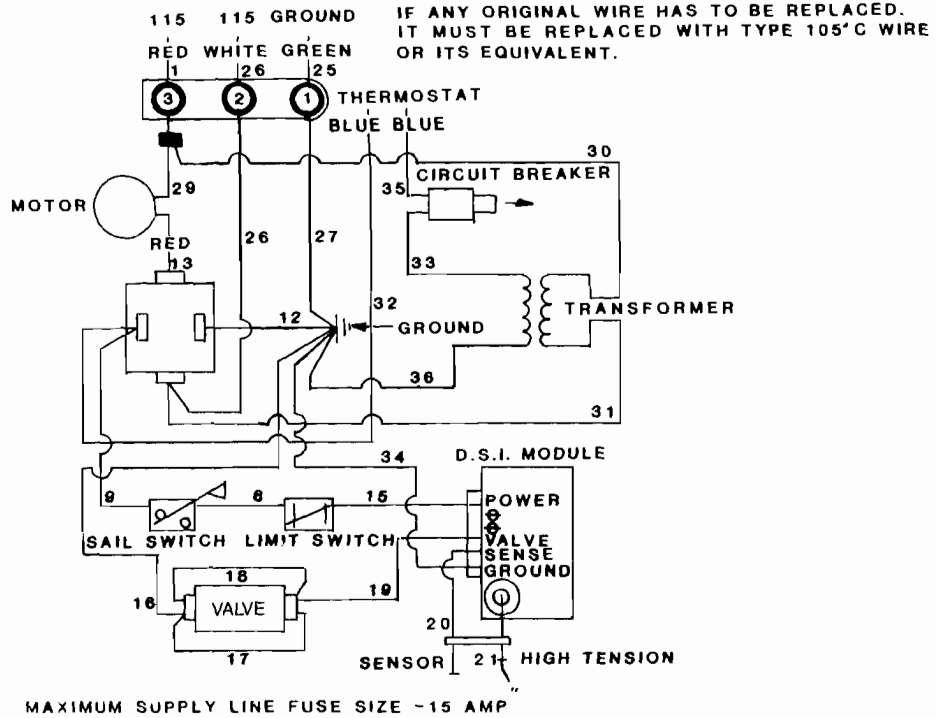

AC-82 SERIES WIRING DIAGRAM FOR (DSI) MODELS (12 VDC SYSTEM)

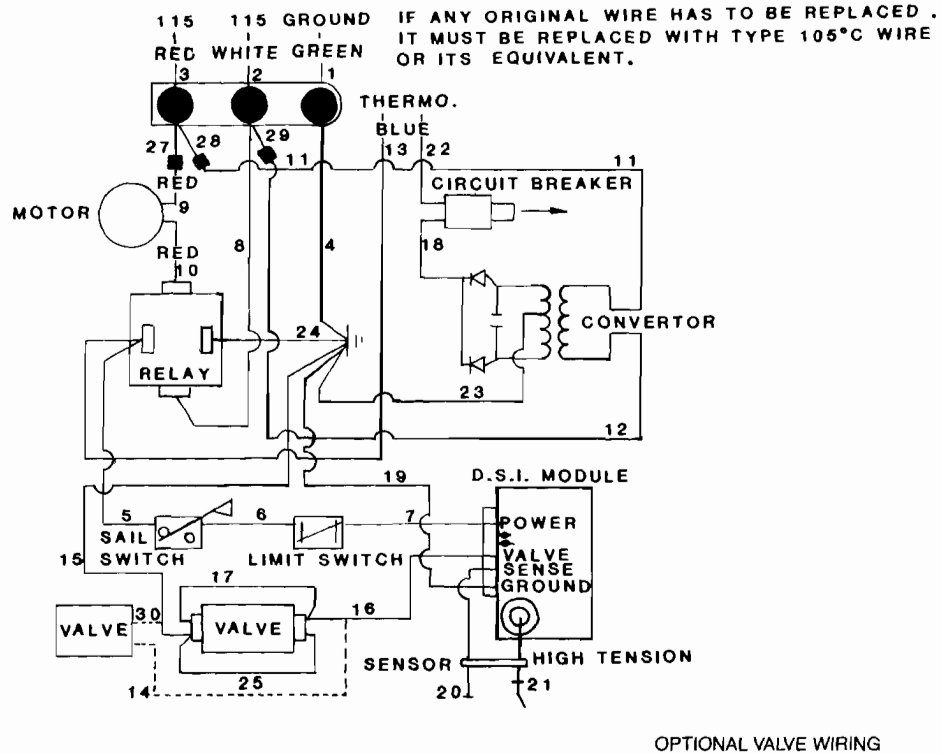

FA-78, DC-82 SERIES WIRING DIAGRAM FOR (PILOT) MODELS

IF ANY ORIGINAL WIRE HAS TO BE REPLACED
IT MUST BE REPLACED WITH TYPE 105°C
WIRE OR ITS EQUIVALENT.

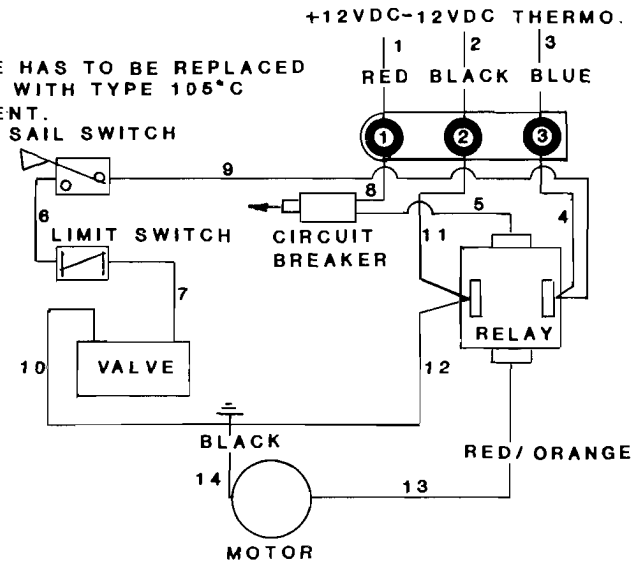

" MAXIMUM SUPPLY LINE FUSE SIZE - 15 AMP. "

HYDRO FLAME CORPORATION

1874 South Pioneer Road
Salt Lake City, Utah 84104
Phone (801) 972-4621
1-800-654-4614