

DUO-THERM

OWNER'S MANUAL 901 Series

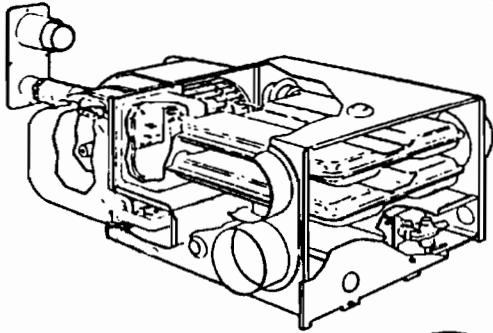

Gas Direct-Vent Forced Air
Furnaces for Mobile Homes
or Recreational Vehicles

**DIRECT SPARK
IGNITION MODELS**

FOR YOUR SAFETY WHAT TO DO IF YOU SMELL GAS:

1. Do not try to light any appliance.
2. Do not touch any electrical switch; Do not use any phone in your vehicle.
3. Immediately call your gas supplier from a neighbor's phone. Follow the gas supplier's instructions.
4. If you cannot reach your gas supplier, call the fire department.

CLOTHING OR OTHER FLAMMABLE MATERIAL SHOULD NOT BE PLACED ON OR NEAR THE APPLIANCE.

DO NOT STORE OR USE GASOLINE OR OTHER FLAMMABLE VAPORS AND LIQUIDS IN THE VICINITY OF THIS OR ANY OTHER APPLIANCE.

CHILDREN AND ADULTS SHOULD BE ALERTED TO THE HAZARDS OF HIGH SURFACE TEMPERATURES AND SHOULD STAY AWAY TO AVOID BURNS OR CLOTHING IGNITION.

YOUNG CHILDREN SHOULD BE CAREFULLY SUPERVISED WHEN THEY ARE IN THE SAME ROOM AS THE APPLIANCE.

**- IMPORTANT INSTRUCTIONS -
MUST STAY WITH UNIT
OWNER READ CAREFULLY**

KEEP FOR FUTURE REFERENCE

WARNING

IMPROPER INSTALLATION, ADJUSTMENT, ALTERATION, SERVICE OR MAINTENANCE CAN CAUSE INJURY OR PROPERTY DAMAGE. REFER TO THIS MANUAL. FOR ASSISTANCE OR ADDITIONAL INFORMATION, CONSULT A QUALIFIED INSTALLER, SERVICE AGENCY, OR GAS SUPPLIER.

THIS UNIT MUST BE SERVICED ONLY BY AN AUTHORIZED SERVICEMAN. MODIFICATION OF THE APPLIANCE CAN BE EXTREMELY HAZARDOUS AND COULD LEAD TO SERIOUS INJURY OR DEATH.

FUEL BURNING APPLIANCES GENERATE TOXIC FLUE PRODUCTS. MODIFICATION OR IMPROPER MAINTENANCE CAN CAUSE CARBON MONOXIDE IN DEADLY AMOUNTS. TO PREVENT THIS, MAINTAIN APPLIANCE IN SAFE OPERATING CONDITION.

DO NOT BLOCK OR MODIFY ANY COMBUSTION AIR OR FLUE GAS PASSAGEWAYS.

DO NOT ADD ANY DEVICES OR ACCESSORIES TO THIS APPLIANCE EXCEPT THOSE SPECIFICALLY AUTHORIZED BY DUO-THERM

ALWAYS CONSULT YOUR AUTHORIZED SERVICEMAN FOR ANY PROBLEMS OR QUESTIONS YOU MAY HAVE PERTAINING TO THIS APPLIANCE.



ALWAYS INSPECT THE APPLIANCE BEFORE STARTING A NEW HEATING SEASON, PAYING SPECIAL ATTENTION TO COMBUSTION AIR, FLUE GAS PASSAGEWAYS AND FUEL LINES.

1. FOR YOUR SAFETY READ BEFORE OPERATING

WARNING: If you do not follow these instructions exactly, a fire or explosion may result causing property damage, personal injury or loss of life.

- A. This appliance does not have a pilot. It is equipped with an ignition device which automatically lights the burner. Do **NOT** try to light the burner by hand.
- B. **BEFORE OPERATING** smell all around the appliance area for gas. Be sure to smell next to the floor because some gas is heavier than air and will settle on the floor.
- WHAT TO DO IF YOU SMELL GAS**
- Do not try to light any appliance.
 - Do not touch any electric switch; do not use any phone in your vehicle.
 - Immediately call your gas supplier from a neighbor's phone. Follow the gas supplier's instructions.
 - If you cannot reach your gas supplier, call the fire department.
- C. Use only your hand to turn the manual valve lever. Never use tools. If the lever will not turn by hand, don't try to repair it; call a qualified service technician. Force or attempted repair may result in a fire or explosion.
- D. Do not use this appliance if any part has been under water. Immediately call a qualified service technician to inspect the appliance and to replace any part of the control system and any gas control which has been under water.

OPERATING INSTRUCTIONS

1. **STOP!** Read the safety information above on this page.
2. Set the thermostat to lowest setting.
3. Turn off all electric power to the appliance.
4. This appliance is equipped with an ignition device which automatically lights the burner. Do **NOT** try to light the burner by hand.
5. Remove control access panel.
6. Turn manual valve lever counterclockwise  90° to "OFF" position.
7. Wait five (5) minutes to clear out any gas. If you then smell gas, **STOP!** Follow "B" in the safety information above on this page. If you don't smell gas, go to next step.
8. Turn manual valve lever clockwise  90° to "ON" position.
9. Replace control access panel.
10. Turn on all electric power to the appliance.
11. Set thermostat to desired setting.
12. If the appliance will not operate, follow the instructions "To Turn Off Gas To Appliance" and call your service technician or gas supplier.
13. Should overheating occur, or the gas supply fail to shut off, shut off the manual gas valve to the appliance before shutting off the electrical supply.

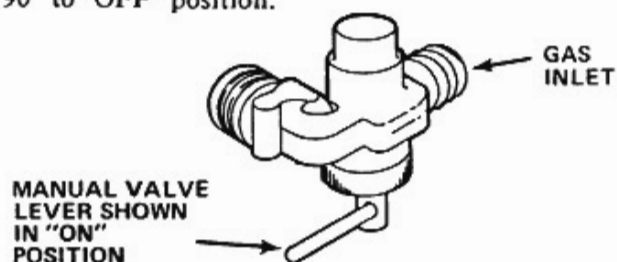

TO TURN OFF GAS TO APPLIANCE

1. Set the thermostat to lowest setting.
2. Turn off all electric power to the appliance if service is to be performed.
3. Remove control access panel.
4. Turn manual valve lever counterclockwise  90° to "OFF" position. Do not force.
5. Replace control access panel.

B. GROUNDING: It is essential to proper operation that the system be properly grounded. If a spark is present and the gas valve opens but the system shuts down after the trial for ignition period, check for proper ground. The following items should be checked:

1. The ground screw connecting the black motor lead, yellow power supply lead, and blue thermostat wire to the casing.
2. The screws attaching the stabilizing burner/electrode assembly to the burner box.

C. WIRING: Check all wiring for proper and secure connections. Be sure the AMP connector is fully engaged on the control board. Check the high voltage wire for proper connection at both ends. Clean any corrosion that may interfere with good electrical contact.

D. HIGH VOLTAGE MALFUNCTION: (See CAUTION below). If during the trial for ignition, the spark is intermittent (the valve may or may not open) the following should be checked:

1. Electrode spark gap - should be $1/8" \pm 1/32"$.
2. Ceramic insulators - check for cracks.
3. Electrode lead wires - check for cracks or breaks.

CAUTION

THE ELECTRODE WIRES ARE VERY BRITTLE AND WILL EASILY BREAK OFF IF ATTEMPTS ARE MADE TO BEND THEM.

E. VALVE MALFUNCTION: If there is power to gas valve and a spark during the trial for ignition, but the valve will not open, check the valve for an open coil or other malfunction.

F. ERRATIC OPERATION: If the system operates properly for a period of time but randomly shuts down during the duty cycle, or will not operate during cold starts, check the flame proving circuit (sensor wire) with a DC Microamp Meter:

1. With a Fenwal electronic circuit board the current should be at least 5 microamps at ignition. A low or marginal flame current may cause nuisance tripping. After three minutes operation, a reading of at least 8 microamps is normal.

2. With a Channel Products electronic circuit board the current should be 0.5 microamps after three minutes operation.

If low readings are encountered, check the sensor circuit wiring to be sure the connectors are tight and the sensor wire is not in direct contact with metal or the spark wire.

G. The solid state control module is not field repairable. Any modifications or repairs could alter the function of sensitive electronic circuits, and cause unsafe operation.

For more detailed service information on the DIRECT SPARK IGNITION SYSTEM refer to the Duo-Therm DSI Service Guide (Form No. 191085).

14. GAS SUPPLY

Low gas pressure can lead to unsatisfactory furnace operation (nuisance lockout, high pitched noise during operation, reduced heat output, etc.) Be sure that the gas line pressure at the furnace is 11 inches WC during furnace operation. This line pressure will result in a 9.5 to 10.5 in. manifold pressure at the gas valve manifold tap. Low gas line pressure can be corrected by adjusting the propane tank regulator. This adjustment should be made only by a qualified service person.

At low temperatures partially filled propane tanks may not be able to deliver sufficient gas to maintain adequate line pressure. For example, a 50% full 30 pound propane tank at 0°F. can only supply 22,600 BTU's of gas each hour; a 30% full tank will further reduce this supply to 17,600 BUT's per hour and a 50% full 30 pound tank at -10°F. will deliver only 11,300 BTU's per hour. When the demand on the system is greater than it can supply, line pressure will be reduced which will adversely affect the operation of the appliance.

B. COMPLAINT - EXCESSIVE NOISE

1. Motor or blower wheel out of balance. Replace motor or blower wheel.
2. Motor hum. Replace motor.
3. Burner rumble (pulsation). High voltage to the furnace, over 13.5 volt DC and/or extreme cold can cause the burner to rumble or pulsate. This can be corrected by moving the air shutter (FIG. 6) toward "A". Do not move the air shutter any further than necessary to correct the noise. Reducing the air too much can result in poor performance and reduced efficiency.
4. Howling/Screeching. Low voltage, less than 10.5 volt DC, may cause the furnace to emit a high pitched screech or howl. If the cause for low voltage cannot be corrected immediately, the air shutter can be moved toward "F". Do not move the air shutter any further than necessary to correct the problem.

- CAUTION -

WHEN THE CAUSE OF THE LOW VOLTAGE IS CORRECTED IT MAY BE NECESSARY TO RETURN TO THE ORIGINAL AIR SHUTTER SETTING TO OBTAIN SATISFACTORY OPERATION.

C. COMPLAINT - ERRATIC FAN OPERATION

A loose terminal or a defective relay may cause the motor to cycle off while the thermostat is calling for heat. Repair terminal or replace relay.

D. COMPLAINT - AMPERAGE DRAW THROUGH FURNACE WITH THERMOSTAT "OFF"

1. Incorrect wiring. If 12 volt and thermostat wires are not connected properly at the furnace a continuous circuit can be created through the heater of the fan relay. If this condition exists the blower will start as soon as the thermostat closes and will shut off when the thermostat opens, instead of having a delayed action. In some cases this will also burn out the heat anticipator in the thermostat.

Refer to the wiring diagram for correct connections.

2. Internal short to ground in gas control or motor. Disconnect all wiring to control or motor (disconnect ground screw on black motor lead from casing) and use an ohmmeter to check for shorts to ground. At no point should there be a reading between the electrical circuit of the motor or control and ground.

13. DIRECT SPARK IGNITION SYSTEM

DESCRIPTION

The direct spark ignition system consists of a solid state printed circuit control module, an electrode assembly, a 12 volt gas control and connecting high and low voltage wires.

To ignite the burner it is necessary only to set the thermostat. The thermostat, in series with the air prover switch, powers the ignitor to simultaneously open the main burner valve and provide the ignition spark. On some models there is up to a 30 second delay from the time the blower starts until the gas valve opens and the spark is started.

Electronic flame sensing circuitry in the ignitor detects the presence or absence of main burner flame. If the flame is not established during the Flame Establishing Period, the system closes the gas valve and locks out. On some models a second and third attempt to light the burner will be made after a period of time of up to 30 seconds between tries. If the flame is extinguished during the ignition cycle, the ignitor will retry for ignition before going into lockout. To reactivate or retry for ignition, if lockout has occurred, set the thermostat to the "OFF" position for 4 to 5 seconds, then reset to the "ON" position.

TROUBLE SHOOTING GUIDE

CAUTION

SERVICING THIS DEVICE SHOULD ONLY BE PERFORMED BY A QUALIFIED SERVICEMAN WITH DUE REGARD FOR SAFETY AS IMPROPER ACTIONS COULD RESULT IN A HAZARDOUS CONDITION, RESULTING IN SERIOUS INJURY OR DEATH.

WARNING

DO NOT APPLY POWER TO CONTROL MODULE UNLESS WIRING CONNECTIONS ARE COMPLETE AND ELECTRODE IS PROPERLY GROUNDED.

USE EXTRA CAUTION IN AREAS WHERE HIGH VOLTAGE IS PRESENT.

- A. INPUT POLARITY: If a spark is present and the gas valve opens but the system shuts down after the trial period, check input voltage for proper polarity.

11. THERMOSTAT ADJUSTMENT

This unit is equipped with an adjustable thermostat. Improper setting of the heat anticipator can cause either abnormally short or long heating cycles resulting in discomfort.

For correct heating anticipator adjustment, proceed as follows:

Cycle system to determine if cycling rate is satisfactory. If adjustment is necessary, move pointer to a higher setting for longer "ON" cycle and to a lower setting for shorter "ON" cycle.

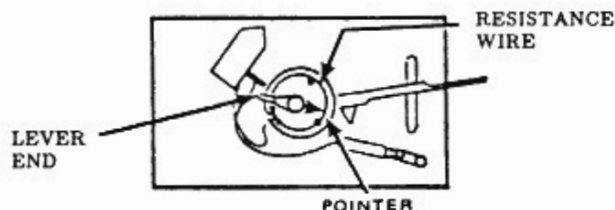

12. SERVICE HINTS, DIAGNOSIS AND CORRECTIVE MEASURES

Installation and service should be done by a qualified service person. The appliance should be inspected before use and at least annually by a professional service person. More frequent cleaning may be required due to excessive lint from carpeting, bedding material, etc. It is imperative that control compartments, burners and circulating air passageways of the appliance be kept clean.

A. COMPLAINT - NO HEAT

1. Check electrical supply to make sure that 12 volt DC is available at unit. Battery must be charged. If battery is low, there may be sufficient power to run the blower but not enough to run the blower at full speed. If the blower does not run at it's prescribed speed, the combustion air switch cannot engage and gas will not flow. Be sure the connections to the voltage lines are tight.
2. Manually rotate fan to make sure motor is free to turn.
3. Check for blown fuse in 12 volt circuit to furnace.

SHORT CIRCUIT CHECKOUT

4. If fuses are blown, a short is indicated and should be checked.
 - a. Turn off all appliances including furnace.
 - b. Install an ammeter on the positive side of the battery. Amperage reading should be 0. If an amperage reading

is noted, a short exists in the vehicle electrical system.

- c. Disconnect the red (+) DC lead at the furnace. If the amperage continues, the short is exterior to the furnace. If the amperage reading ceases, the furnace electrical system is shorted or miswired (see SECTION D. COMPLAINT - AMPERAGE DRAW THROUGH FURNACE WITH THERMOSTAT "OFF") and should be checked.
5. GAS SUPPLY: Be sure manual gas valve is in the open position.
 6. THERMOSTAT OFF: Check to be sure thermostat is properly wired and is calling for heat.
 7. MALFUNCTIONING COMBUSTION AIR SWITCH: Be sure the combustion air switch is moving far enough to close its contacts. If the switch is not closing, clean any dust or dirt from the actuator pin. Other reasons for switch not operating are:
 - a. Insufficient fan speed (slow motor due to low charged battery, faulty motor or line and dust accumulation restricting return air to furnace). Check wiring in accordance with unit's wiring diagram to assure that the proper polarity of the 12 volt DC power supply is observed. On certain models this polarity must be observed so the motor will run the proper direction of rotation to insure correct air delivery.
 - b. Faulty Combustion Air Switch: Replace switch if valve does not open when switch is engaged. Switch should also be replaced if battery is fully charged and with the fan motor running at top speed the switch fails to engage within 3 to 4 seconds.
 8. GAS CONTROL VALVE: With test light check valve terminals. If voltage is present, but valve is not opening (when combustion air switch engages), replace control valve.
 9. FAN NOT OPERATING: Check for burned-out motor or loose wiring terminals.
 10. DEFECTIVE FAN RELAY: Relay may be at fault if motor fails to start when thermostat calls for heat. This can be suspected if the thermostat is raised and the motor fails to operate within 60 seconds.

7. BLOWER ASSEMBLY / BURNER

One motor is used to drive both the combustion air and the circulating air blower wheels. Although one motor drives both wheels, the blowers are separate. The combustion air blower

is sealed so as to allow no passage of air between it and the circulating room air blower. Also the combustion air blower serves to "PRE-MIX" the gas and air before it is burned. The combustion air blower draws air from the outside atmosphere and, at the same time, the gas control allows gas to flow into the combustion air stream where it is mixed; then expelled through a ceramic burner head where it is ignited in the combustion chamber. See FIG. 7A.

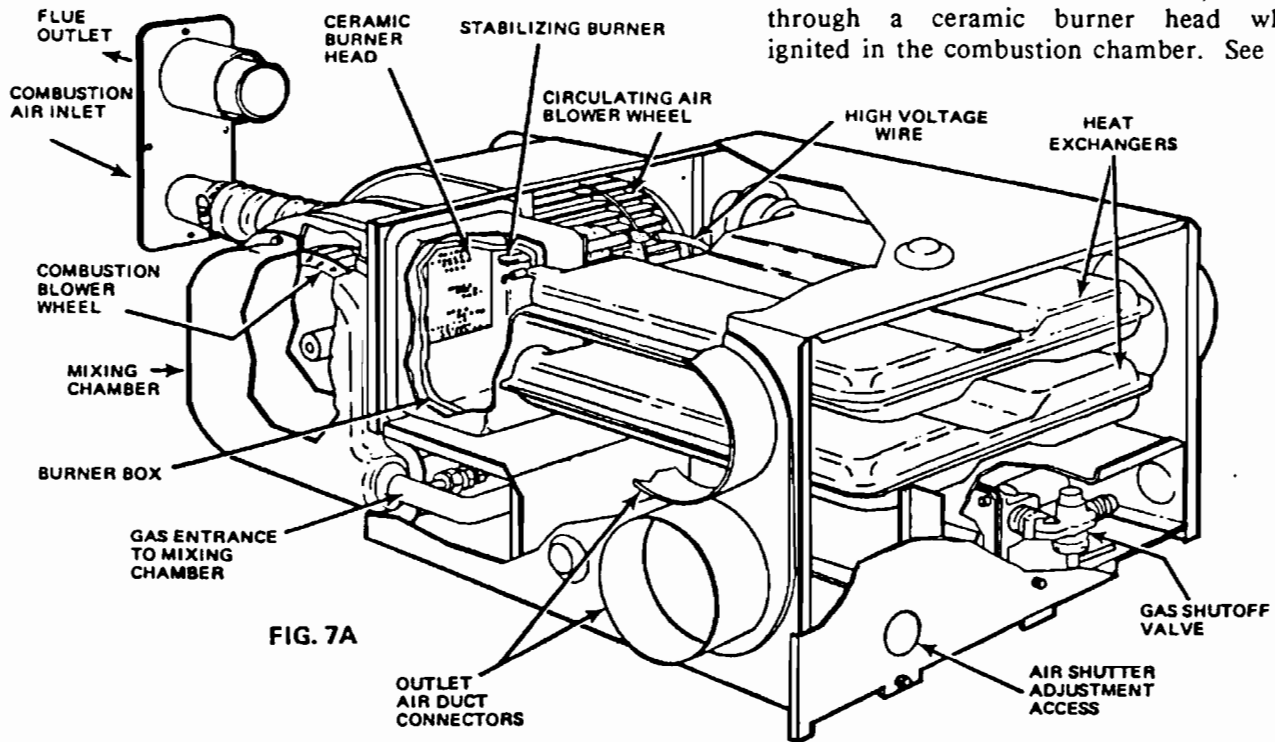

8. OPTIONAL AC-DC CONVERTOR

A convertor is available to operate this unit from a 120 volt AC power supply.

9. MAINTENANCE AND CLEANING

NOTE: For continued satisfactory performance of this unit it is necessary to keep the control compartment clean. It is also important to keep the appliance area clear and free of combustible materials, vapors and liquids.

Routine inspection, maintenance and cleaning of the venting system is recommended at least on a yearly basis. Gas connections should be checked several times a year and after any extended road trip.

This unit is equipped with a sealed motor and requires no oiling.

10. TO REMOVE FURNACE FOR SERVICE

1. Remove front panel (5 screws).
2. Turn off gas supply to the furnace and disconnect gas line.
3. Turn off power supply to furnace and disconnect the wiring.
4. Remove flue vent assembly outside vehicle and disconnect flexible combustion air hose.
5. Remove screw on bottom flange of electrical box which secures inner furnace assembly to the casing bottom. See FIG. 10A.

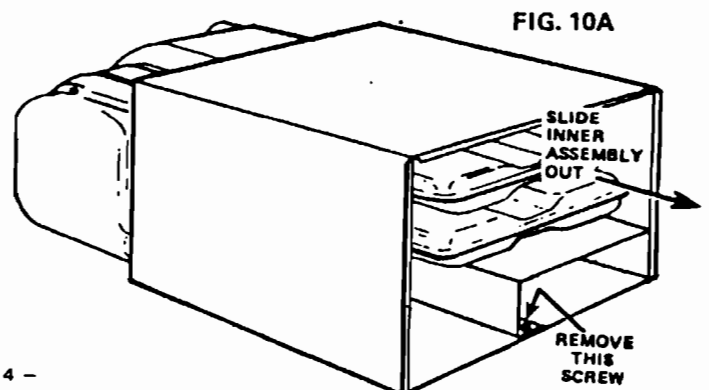

The area in which this furnace is installed must be kept clean. DO NOT store anything around the furnace that will restrict the air flow to the blower which is located at the rear of the furnace. NEVER place hazardous materials such as aerosol cans, plastic containers, gasoline, or any other flammable materials near the furnace.

BEFORE PROCEEDING CHECK ALL CONNECTIONS WITH A SOAP SOLUTION TO DETECT LEAKS. THIS ALSO SHOULD INCLUDE A CHECK OF THE FURNACE CONTROLS AND PIPING. NEVER CHECK FOR LEAKS WITH A LIGHTED MATCH.

2. SEQUENCE OF NORMAL OPERATION

1. When the thermostat calls for heat, a delay of 15 to 30 seconds will elapse before the time delay relay energizes the fan motor.
2. As the fan motor reaches approximately 75% of the normal r.p.m. (within 1 to 2 seconds) the sail switch, in response to the air flow, will engage allowing current flow to the electronic control board.
3. The electronic control board on certain models will immediately open the gas valve and energize the sparking circuit. Other models have a delay of up to 30 seconds before the gas valve is opened and the sparking circuit is energized.
4. The spark ignites a stabilizing burner which in turn lights the main burner.
5. Once the thermostat is satisfied or turned back, the gas valve will close and the flame on the main burner will go out. The blower will continue to run for a short period of time and will then shut off. The purpose of this is to remove most of the remaining gases and heat from the exchanger.

3. TIME DELAY FAN RELAY

This relay controls the sequence of the blower operation. When the bimetal disc of the relay is heated internally to the operating temperature, the switch closes. This completes the circuit to the motor. The blower will continue to run as long as the relay is hot even though the thermostat is satisfied and the main burner is off. When the relay sensor cools, after the thermostat is satisfied, the switch opens and the blower shuts off.

4. LIMIT SWITCH

The purpose of the limit control is to turn off the gas to the main burner if for any reason the furnace becomes abnormally hot. If the circulating air is blocked, even partially, the limit control will function and cause the main burner to cycle.

If the limit control is damaged, it cannot be repaired. It must be replaced with a new one. **CAUTION: NEVER SHORT ACROSS OR BYPASS THE LIMIT CONTROL EVEN FOR ONLY TEMPORARY OPERATION.**

5. AIR SWITCH

The combustion air switch has two purposes:

1. It is an "air prover". It operates in response to the flow of air generated by the blower wheel. Hence, if for any reason the air from the blower wheel is not sufficient, the switch will not operate. One cause of insufficient air is a slow motor caused by low voltage.
2. The switch allows time for the blower to pull in a sufficient amount of air for combustion before it engages. Once it engages, the gas valve opens and gas flows to the combustion air blower mixing chamber.

6. AIR SHUTTER ADJUSTMENT

The air shutter has been factory set to operate over a wide range of outdoor temperatures and at reasonable altitudes. Operation at higher altitudes (generally above 5000 feet), and extremely cold temperatures, may require an adjustment to the air shutter.

During extreme cold the air shutter should be moved closer to the 'A' setting, refer to FIG. 6 and SECTION "12. SERVICE HINTS, DIAGNOSIS AND CORRECTIVE MEASURES".

AIR SHUTTER ADJUSTMENT ACCESS PLUG REMOVED (SEE FIG. 7A)

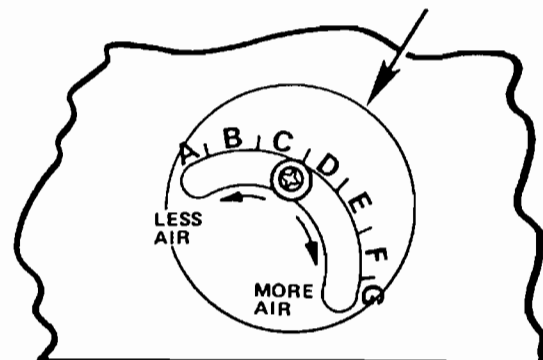
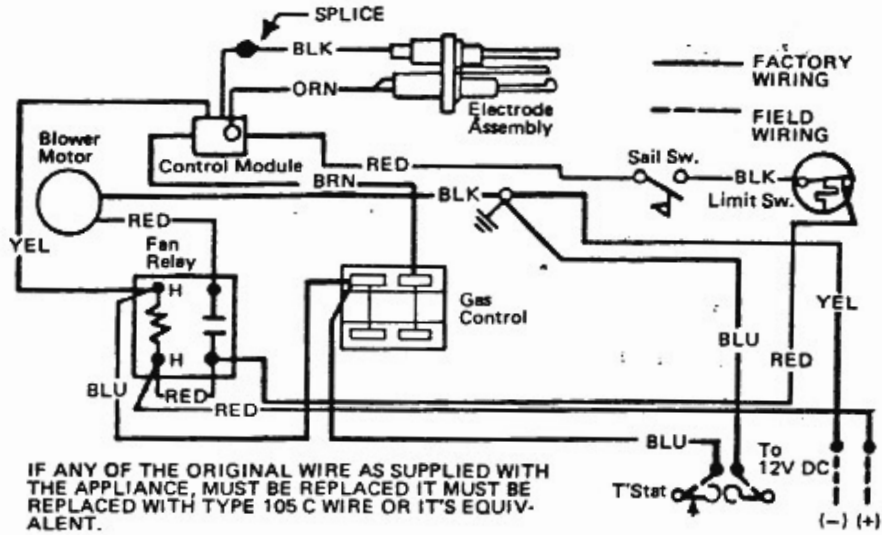

FIG. 6

WIRING DIAGRAM



SCHEMATIC

