

WINEGARD® SENSAR® ANTENNAS

INSTALLATION/OPERATION MANUAL (All Models)

MADE IN U.S.A.

(Sensar® III head - U.S. Patent D500,496)

STEP 1: Choose location for antenna. Figure 1 illustrates placement of the Sensar, showing it in travel position. You must be able to raise and rotate antenna without interfering with other roof-mounted equipment. Make sure inside ceiling area is clear to mount ceiling plate.

NOTE: Figure 1 shows the minimum distance the mount can be located from edge of vehicle roof. Check with your dealer or the manufacturer for information about options in the roof for mounting the antenna. A reinforced roof area, or a prewired coax cable, may be available. For sloped/round roofs, use Winegard Model RW-2000 exterior roof wedge, to level installation. An interior wedge, IW-5000, is also available.

STEP 2: Using template on page 7, drill 1-3/4" hole through roof and ceiling of vehicle. Be careful not to damage any wiring between roof and ceiling.

STEP 3: Drill 1/2" hole for cable entry through roof of vehicle only. DO NOT DRILL THROUGH CEILING. Route cable through ceiling and wall to power supply location.

STEP 4: The mount is designed to fit roofs from 1" to 4-3/4" thick. As supplied, the mount will fit a roof 4-3/4" thick. If roof is less than 4-3/4" thick, cut elevating shaft and directional handle to size, steps shown in figures 2, 3, 4 and 5. **If roof is more than 4-3/4" thick (max. 7"), a directional handle extension is needed. Order Winegard Model EK-1036, Directional Handle Extension.**

IMPORTANT: The handle and extension must be glued together *after checking that you have the correct length.* The handle will not work properly if it is not glued together! (PVC glue is recommended; for your safety, use according to manufacturer's directions.)

NOTE: If using roof wedge RW-2000 or interior wedge IW-5000, put in place before installing base plate or interior hardware.

STEP 5: Center elevating shaft in hole on roof. Temporarily secure base plate to roof with two screws provided. (Do not apply sealant at this time). Inside unit, make a mark on the shaft 1-1/2" below ceiling and cut shaft on this mark. See figure 2.

After cutting elevating shaft, push directional handle up into ceiling over shaft being careful to align keys inside directional handle onto keyways on bottom of gear housing. (NOTE: The keys only line up one way; do not force. TIP: Pointer on directional handle should point toward back of coach if properly installed.) Make sure directional handle is snug against bottom of baseplate. Measure distance between the bottom of the recess on the handle to the ceiling. See figure 3. Pull handle back down and transfer this dimension to the shaft end of the directional handle. Mark it and cut it off here, fig. 4.

If EK-1036 (directional handle extension) is used, DO NOT CUT EK-1036 extension. Cut excess length from directional handle only. The handle and extension must be glued together *after checking that you have the correct length,* fig. 5.

FIGURE 1

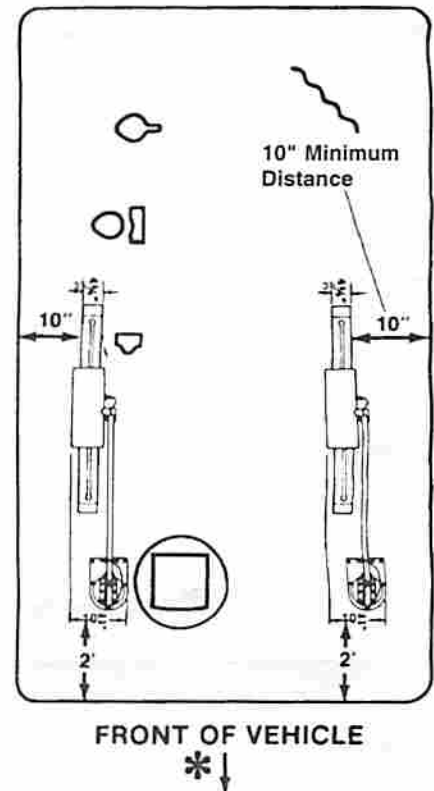

FIG. 2

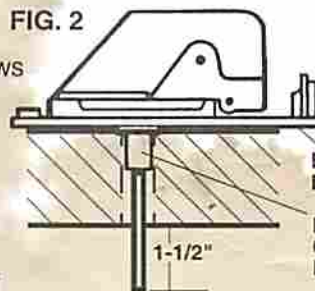

FIGURE 3

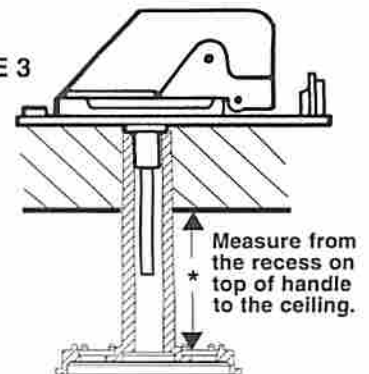
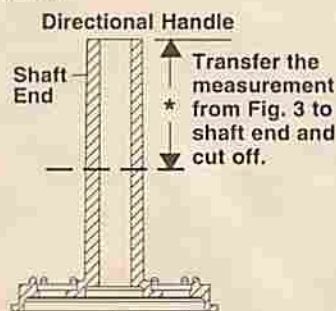

FIG. 4



EK-1036 Extension

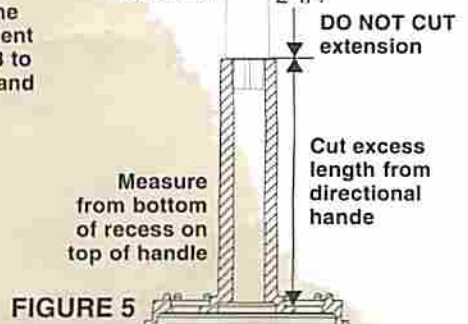

FIGURE 5

ALL MODELS

STEP 6: Attach antenna head to lift tubes with two (2) steel pins, Figure 6. Align holes in leveling bracket on back of antenna head with holes in lift tubes, insert pins and secure in place with (2) E-clips. **Use pliers and get a firm grip on E-clips.** Fit clips into groove on pins and snap into place.

STEP 7: On models made before March, 2004, attach coax connector to jack on back of antenna head, slide weather boot into place over boot collar; shown in Figure 7A. On models made after March, 2004, attach weather resistant coax connector to jack on back of antenna head; shown in Figure 7B.

STEP 8: Mount antenna and lift on roof in travel position. Apply a liberal amount of approved nonhardening sealing compound on bottom of base plate and roof area around hole, Figure 8. Secure base plate with screws provided. Apply sealing compound over mounting screws, Figure 8.

STEP 9: Lay ceiling plate on top of **directional handle** with pointers aligned and slide assembly over **rotating base shaft** in ceiling. Make pilot holes in ceiling. **Mount ceiling plate with directional handle in place** with screws provided, Figure 9.

STEP 10: Assemble directional handle, spring, nylon bearing, directional handle decal and elevating crank as shown in exploded view in Figure 9. Remove backing from crank cover decal and press firmly inside directional handle. Slide all parts over elevating shaft and install elevating crank so set screw is on one of the six flat sides of elevating shaft *before* tightening screw.

WARNING: Once set screw touches shaft, tighten only 1/4 turn more. Set screw simply holds elevating crank on. **DO NOT OVERTIGHTEN!**

NON-AMPLIFIED MODELS ONLY

STEP 11: Run download to TV set location and make connection to antenna terminals of TV set.

FIGURE 8

NOTE: Apply non-hardening sealing compound such as Butyl caulking between Base Plate and roof of vehicle

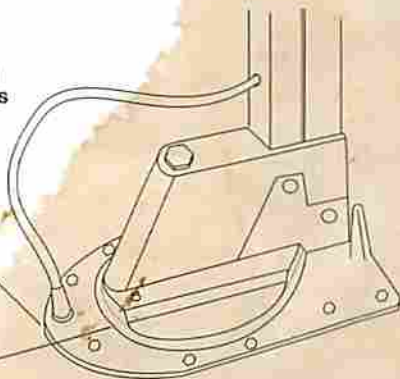

CAUTION: Do not get sealing compound on bearing surface between base plate and Rotating Gear Housing. Do not paint top of Base Plate or around Rotating Gear Housing.

FIGURE 6

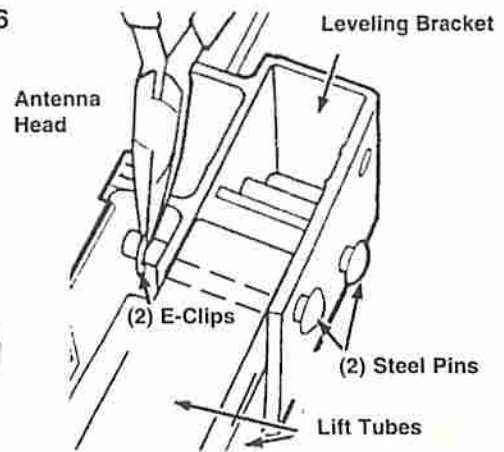

FIGURE 7A

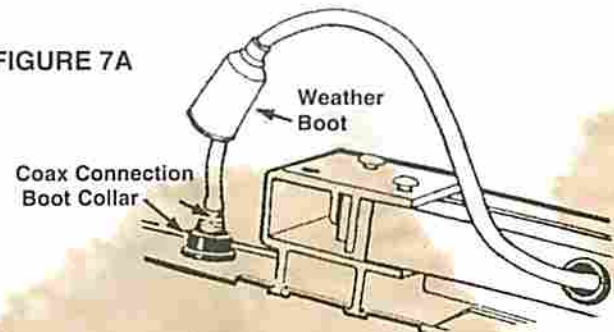

FIGURE 7B

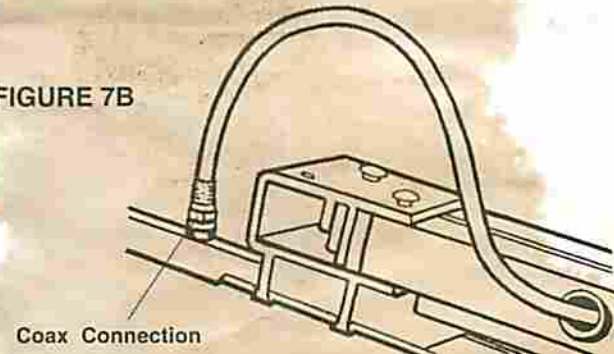
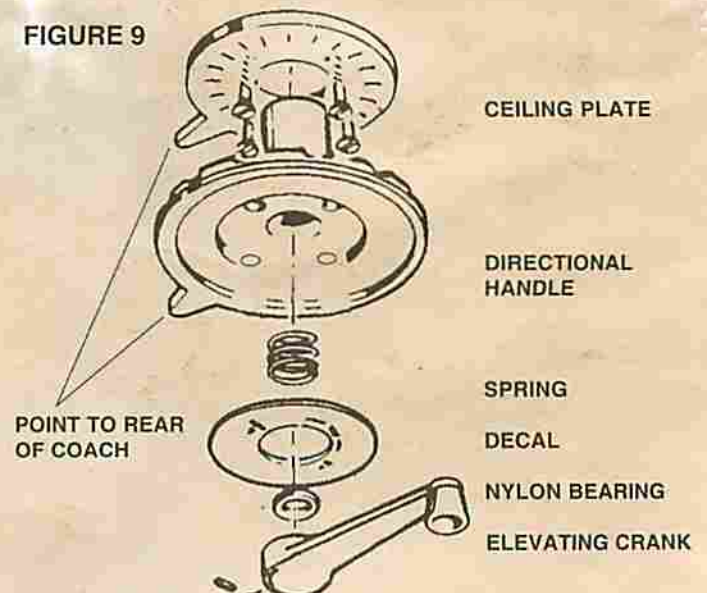

FIGURE 9



AMPLIFIED MODELS ONLY

STEP 11: Select location for wall plate. Run two coax cables (RG-59 type) (three if set 2 jack is going to be used) between locations and install connectors on each end. **Mark cables so "cable input", "TV output"** "Set 2" may be identified. Antenna download and +12 VDC will also be needed at inside wall plate/power supply location.

STEP 12: The wall plate/power supply assembly may be flush mounted in most standard electrical boxes. To flush mount cut a hole in wall to fit the box. Run 2 #12 wires between wall plate/power supply and +12 VDC source and route download cable to this location.

CAUTION
THE POWER SUPPLY SHOULD BE TURNED OFF WHEN CONNECTING CABLES/WIRES TO POWER SUPPLY. SEE FIGURE 14.

STEP 13: Make 12 volt connection to wall plate/power supply, Figure 10. Install terminals on wires from +12 VDC source, Figure 11. Crimp terminals with appropriate crimping tool or equivalent, Figure 12. Push wires onto tabs on terminal board as shown in Figure 10. If in doubt as to the polarity of the wires, connect them temporarily to tabs on circuit board and press ON switch on front of wall plate; if light comes on, polarity is correct, Figure 10.

STEP 14: Install connectors on download, set 2 and cable input cables as shown on page 4. Attach download cable to jack on wall plate/power supply marked antenna, Figure 13. Attach cable going to set 2 outlet to jack on power supply marked SET 2. Attach cable coming from cable input to jack on power supply marked CABLE.

STEP 15: Mount power supply in wall with screws provided and attach TV set cable to jack on front of power supply/wall plate. Press ON switch on front of wall plate and check that light is on, Figure 14.

CHECKING OPERATION OF POWER SUPPLY

1. Tune TV receiver to nearest station and rotate antenna for best picture and sound.
2. Press OFF switch on power supply. Picture on TV should be considerably degraded with power off.
3. **This unit is equipped with a polyswitch,** (current limiting device), which will shut down +12 VDC if there is a direct short between antenna and power supply. Green indicator light will not light. Once short is eliminated, device will reset itself.

ADDING OPTIONAL AMPLIFIED WALLPLATE TO NON-AMPLIFIED RV/TV INSTALLATION

Model RA-7596 solid state TV signal amplifier works with any non-amplified RV/TV antenna. Improves picture quality. Uses +12 VDC; has on/off switch, indicator light, set 2 output, cable input and +12 VDC receptacle.

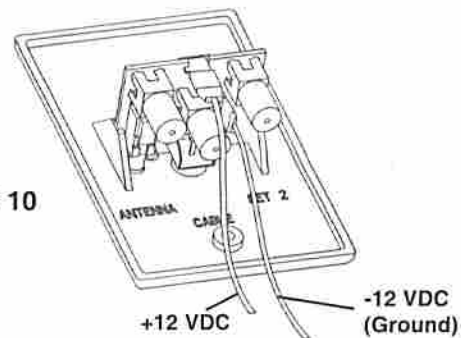

FIGURE 10

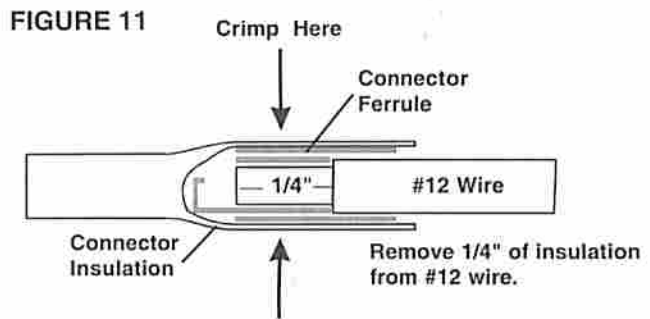

FIGURE 11

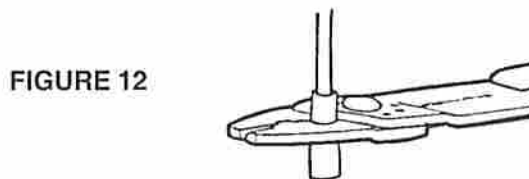

FIGURE 12

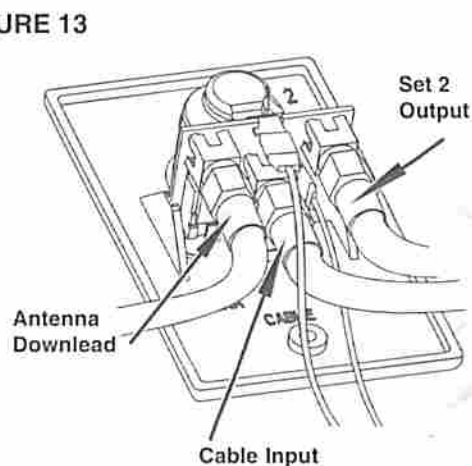

FIGURE 13

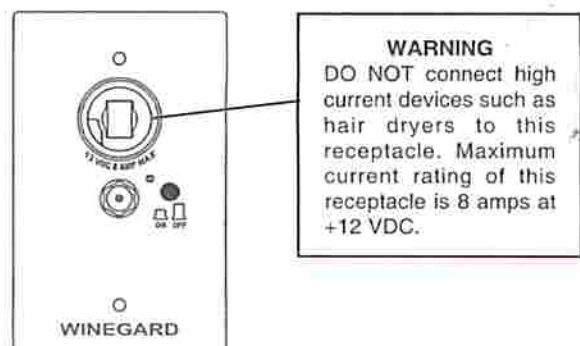
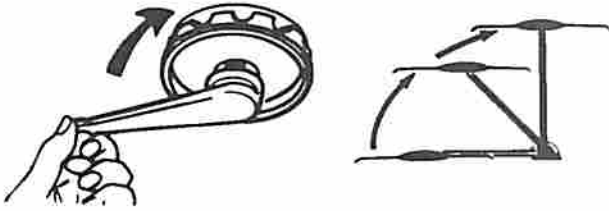

FIGURE 14

WINEGARD® SENSAR® ANTENNAS

OPERATION MANUAL (All Models)

RAISING ANTENNA TO OPERATING POSITION



Turn elevating crank (clockwise) in "UP" direction about 13 turns or until some resistance to turning is noted.

AMPLIFIED MODELS ONLY

Turn power supply ON to use either front or rear TV outlet. Neither outlet will work unless power supply switch is ON.

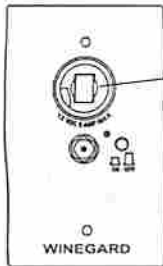

WARNING
DO NOT connect high current devices such as hair dryers to this receptacle. Maximum current rating of this receptacle is 8 amps at +12 VDC.

LUBRICATION (Done annually)

STEP 1: To lubricate the elevating gear, apply a liberal amount of silicone spray lubricant to the elevating gear with the lift in the down position (see illustration). Run the lift up and down to distribute the lubricant over gears.

STEP 2: Two times yearly, or in the event rotating the antenna becomes difficult, normal operation can be restored by lubricating the bearing surface between the rotating gear housing and the base plate. Any **silicone lubricant spray** may be used. Elevate antenna and remove plastic plug from rotating gear housing as shown. Spray lubricant into hole and around edges of gear housing. Rotate gear housing until lubricant coats bearing surfaces and antenna rotates freely.

Lubricate Here

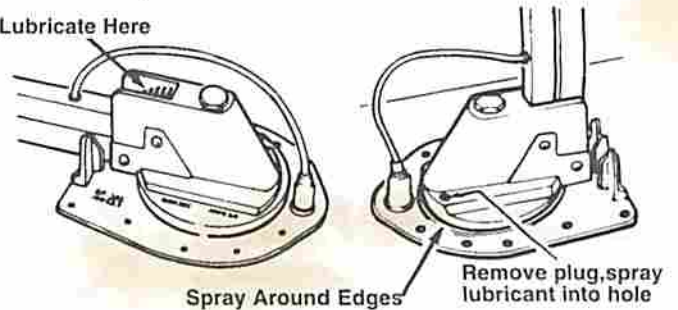

ROTATING ANTENNA FOR BEST PICTURE



Make sure antenna is in "UP" position. Pull down with both hands to disengage ceiling plate. Rotate for best picture.

LOWERING ANTENNA TO TRAVEL POSITION

Rotate antenna until pointer on directional handle aligns with pointer on ceiling plate. Turn elevating crank (counter clockwise) in "DOWN" direction about 13 turns or until resistance is noted. Antenna is now locked in travel position.

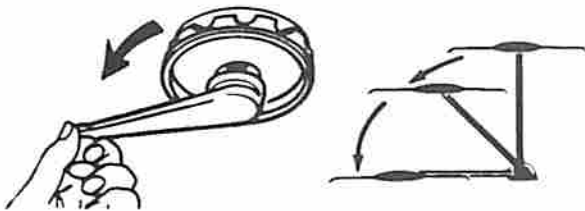

IMPORTANT: Under no conditions lower antenna in any position except travel position.

LUBRICATING RUBBER QUAD RING

Lubricate rubber quad ring on elevating shaft which is below worm gear with silicone spray lubricant at least twice yearly. This will keep quad ring from becoming brittle which could result in leaks down elevating shaft. Refer to page 8 for removing worm gear assembly. Item #6 on parts explosion.

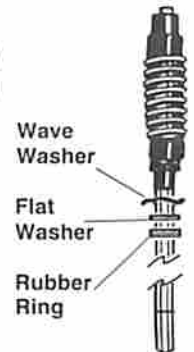

DO'S

1. Check parking location for obstructions before raising antenna.
2. Carefully raise, lower and rotate. If this is difficult, check for cause.
3. Rotate slowly when selecting station and check fine tuning on TV set to make sure it is properly adjusted.
4. Lower antenna before moving vehicle.

DONT'S

1. Don't force elevating crank up or down.
2. Don't rotate directional handle hard against stops.
3. Don't travel with lift in up position.
4. Don't leave lift part way up or down.
5. Don't apply sealing compound or paint over top of base plate or anywhere on lift.

INSTALLING F-CONNECTORS ON COAXIAL CABLE

Step 1. Strip outer cover back 1/2" from end of cable. Fray braid back as far as outer cover will allow.

Step 2. Trim braid close to outer cover and remove 1/4" of inner insulation **being careful not to nick center conductor**. Make sure no foil or braid can touch center conductor.

Step 3. Slide connector tip between braid and inner insulation (braid and foil, on foil shield cable) and push connector on cable as far as it will go. Crimp built-in ferrule with proper crimping tool. **Hex connector requires hex crimping tool.** Do Not crush cable out-of-round.

* If installing in very hot weather, increase these dimensions 1/8".

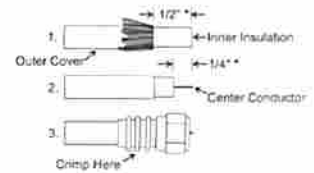

WHAT TO DO WHEN YOUR RV/TV ANTENNA IS NOT WORKING PROPERLY

HOW YOUR SYSTEM WORKS, Figure 1

WARNING

Do not install couplers, splitters, etc. between the power supply and the antenna. Installation of any item on the download may cause a short in the system. The download supplies +12 VDC to the preamp in the antenna.

Turning power supply on sends +12 VDC up cable to antenna. Voltage energizes transistors on amplifier in antenna head. TV signal comes back down cable to outlets.

TO TEST SYSTEM, Figure 2

1. Make sure TV set is working properly.
2. Switch power supply ON and OFF to difference in picture quality while watching TV. If NO there is difference, use following steps.

CAUTION: The power supply should be turned OFF when connecting/disconnecting cables to power supply and antenna, but should be turned ON when testing for voltage.

3. Disconnect cable from antenna and check for +12 VDC at Test Point #1. If there is +12 VDC, the power supply is OK. Replace antenna.
4. If there is NO +12 VDC at Test Point #1, reconnect cable to antenna. Remove power supply from wall and visually inspect for burned/broken parts. If there are ANY broken/burned parts, replace power supply.
5. Disconnect cable from antenna jack on power supply. Check for +12 VDC at Test Point 2. If +12 VDC is present, there is a cable problem connecting the power supply to the antenna. Repair/replace cable
6. If +12 VDC is not present at Test Point # 2, be sure the green indicator light is ON. If not, check the polarity of the red/white wires and the +12 VDC source. If there is still no +12 VDC, replace power supply.

Figure 1

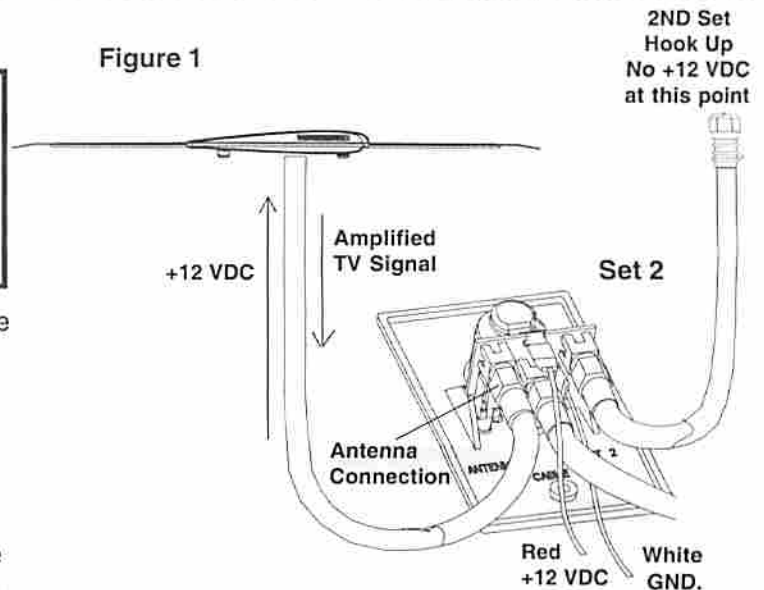
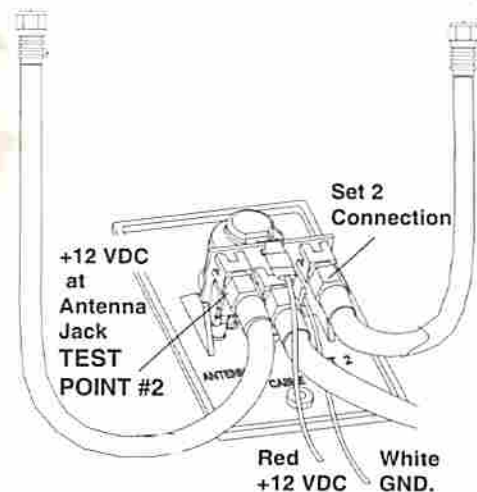

Figure 2

TEST POINT #1
+12 VDC at Antenna

2ND Set
No +12 VDC
at this point





ORDERING REPAIR PARTS

Repair parts are available at many RV dealers and/or service centers throughout the country. If you don't have a dealer/service center near you, call Winegard Company at 1-800-288-8094. All major credit cards accepted. Parts are available **only** in the packages shown here. **Order by the Model No. of the package needed.** Example: To order the elevating gear, order RP-3000. Tax, shipping and handling additional.

PACKAGE	MODEL NO.	PRICE
1 	RV-2005	87.29
	Amplified	
	Antenna Head	
	75 ohm	

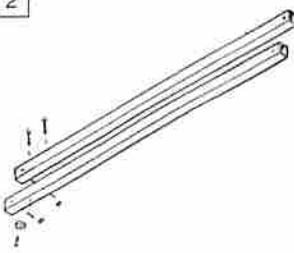
1 	2120566	40.87
	Non-Amplified	
	Antenna Head	
	75 ohm	

2 	RP-2900	17.62
	2 Elevator Tubes	
	2 Grommets	
	4 Pins	
	4 Retaining Rings	
	Rubber Bumper	
	Self Drilling Screw	

FOR MODELS MADE BEFORE 1990 3 	RP-2000	6.26
	Leveling Mount	
	4 Spacers	
	2 Pins	
	2 Rings	

4 	RP-0154	1.69
	Boot	

5 	RP-3000	5.25
	Elevating Gear	

6 	RP-4000	12.35
	Worm Gear & 12.25" Hex	
	Elevating Shaft Assembly w/ Wave Washer	
	Flat Washer	
	"O" Ring	
	Worm Gear Nut	

PACKAGE	MODEL NO.	PRICE
7 	RP-2049	27.67
	Gear Housing	
	2 Pins	
	Bearing	
	Nut *	
	Bearing	
O-Ring Seal		
Retaining Ring		

8 	RP-3523	15.04
	Base Plate	
	10 Screws	
	Rubber Boot	

9 	RP-6200	5.66
	IVORY	
	Directional Handle	
	Ceiling Plate	
	4 Screws	
	Spring	
Decal		

9 	RP-6300	5.66
	WHITE	
	Directional Handle	
	Ceiling Plate	
	4 Screws	
	Spring	
Decal		

10 	RP-6822	2.44
	Spring	

11 	RP-2658	1.58
	Nylon Bearing	

AFTER 1989 12 	RP-5895	6.52
	IVORY	
	Crank, Set Screw	

NEW 1993 12 	RP-6795	6.54
	WHITE	
	Crank, Set Screw	

FITS ALL 13 	SA-1001 IVORY	82.73
	See Drawing at Right	
	Preassembled Elev. Shaft, Gear Hsg., Base Plate	

14 	RW-2000	5.04
	Roof Wedge	

15 	IW-5000	2.17
	Interior Wedge	

16 	EK-1036	2.37
	Directional Handle Extension	

* Remove/tighten with 15/16" 12 socket.
** Use 3/32 Allen Wrench for set screw.

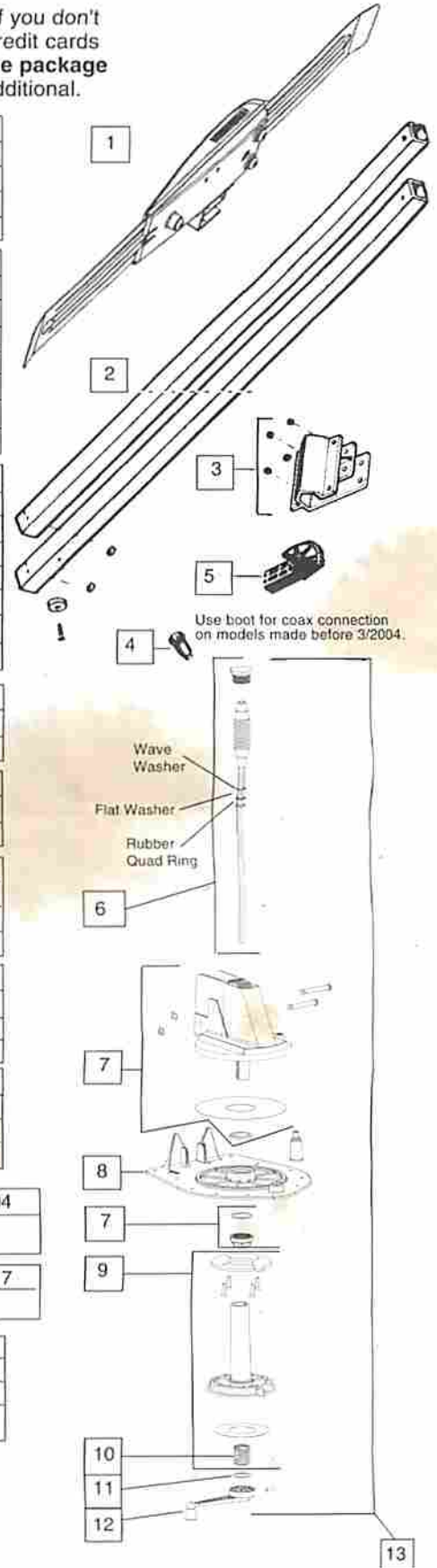

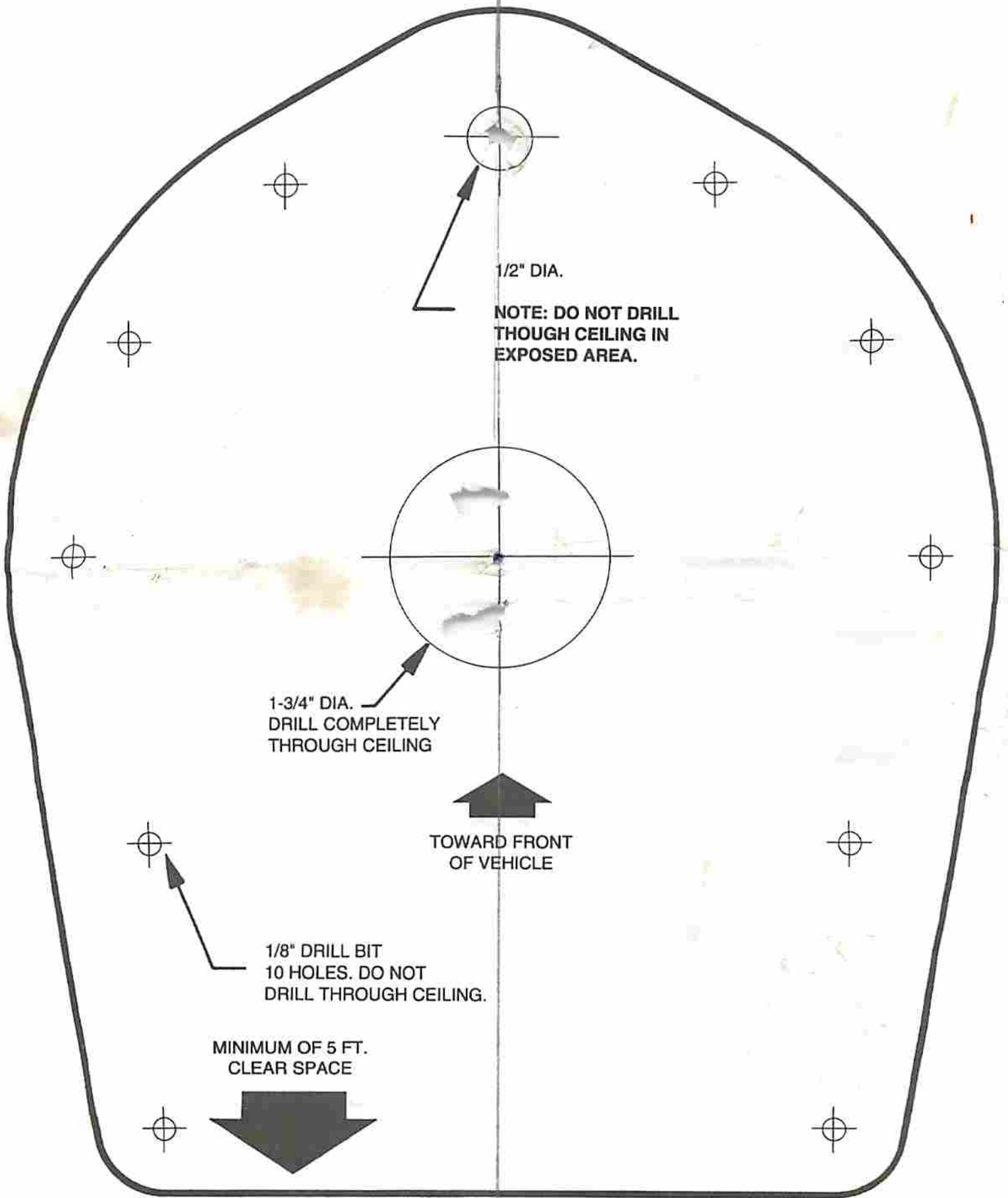

**WINEGARD MOBILE PRODUCTS LIMITED WARRANTY
(2 YEARS PARTS; 1 YEAR LABOR)**

Winegard Company warrants this product against defects in materials or workmanship for a period of two (2) years from the date of original purchase. During year one (1) of such warranty, Winegard Company will also pay authorized labor costs to an authorized Winegard dealer to repair or replace defective products. No warranty claim will be honored unless at the time the claim is made, Customer presents proof of purchase to an authorized Winegard dealer (to locate the nearest authorized Winegard dealer, contact Winegard Company, 3000 Kirkwood Street, Burlington, Iowa 52601, Telephone 800-288-8094 or visit www.winegard.com). Customer must provide proof of purchase with a dated sales receipt for the Winegard product to verify the product is under warranty. If the date of purchase cannot be verified, the warranty period shall be considered to begin thirty (30) days after the date of manufacture.

If a defect in material or workmanship is discovered, Customer may take the product to an authorized Winegard dealer for service. Customer must provide proof of purchase to verify the product is under warranty. If the product is brought to an authorized Winegard dealer for service prior to expiration of year one (1) of the warranty period and a defect in material or workmanship is verified by Winegard Technical Services, Winegard Company will cover the Winegard dealer's labor charges for warranty service. The Winegard dealer must contact Winegard Technical Services in advance for pre-approval of the service. Approval of the service is at the sole discretion of Winegard Company.

Alternatively, Customer may ship the product prepaid to Winegard Technical Services (located at 3111 Kirkwood Street, Burlington, Iowa 52601, Telephone 800-788-4417). Customer must return the product along with a brief description of the problem and provide Winegard Technical Services with Customer's name, address, and phone number. Customer must also provide proof of purchase to verify the product is under warranty. If the product is returned before the expiration of the warranty period, Winegard Company will (at its option) either repair or replace the product.

This Limited Warranty does not apply if the product has been damaged, deteriorates, malfunctions or fails from: improper installation, misuse, abuse, neglect, accident, tampering, modification of the product as originally manufactured by Winegard in any manner whatsoever, removing or defacing any serial number, usage not in accordance with product instructions or acts of nature such as damage caused by wind, lightning, ice or corrosive environments such as salt spray and acid rain.

RETURN AUTHORIZATION POLICY

A Return Material Authorization (RMA) is required prior to return of product to Winegard Company or Winegard Warranty Services under this warranty policy. Please call our Technical Services Department at 800-788-4417 or send an email to warranty@winegard.com to obtain the RMA number. Please furnish the date of purchase when requesting an RMA number. Enclose the product in a prepaid package and write the RMA number in large, clear letters on the outside of the package. To avoid confusion or misunderstanding, a shipment(s) without an RMA number(s) or an unauthorized return(s) will be refused and returned to Customer freight collect.

WINEGARD COMPANY DOES NOT ASSUME ANY LIABILITIES FOR ANY OTHER WARRANTIES, EXPRESS OR IMPLIED, MADE BY ANY OTHER PERSON.

ALL OTHER WARRANTIES WHETHER EXPRESS, IMPLIED OR STATUTORY INCLUDING WARRANTIES OF FITNESS FOR A PARTICULAR PURPOSE AND MERCHANTABILITY ARE LIMITED TO THE TWO YEAR PERIOD OF THIS WARRANTY.

In states that do not allow limitations on implied warranties, or the exclusion of limitation of incidental or consequential damages, the above limitations or exclusions do not apply.

Some states do not allow limitations on how long an implied warranty lasts, or the exclusion of limitation of incidental or consequential damages, so the above limitations or exclusions may not apply to you.

This warranty gives Customer specific legal rights. Customer may also have other rights that may vary from state to state.

SATELLITE RECEIVER WARRANTY:

See manufacturer's limited warranty policy.

Rev. 2/08

ELEVATING SHAFT & WORM GEAR ASSEMBLY REPLACEMENT PROCEDURE

NOTE: It is not necessary to remove rotating gear housing from base plate or remove antenna from roof to replace the shaft & worm gear assembly .

Step 1: Lower antenna to travel position. Loosen set screw on elevating crank, remove crank, spring, directional handle.

Step 2: Remove top retaining ring from top pin holding top elevating tube in rotating gear housing and remove pin.

Step 3: Remove plastic plug from top of rotating gear housing, disengage elevating gear, remove elevating shaft assembly .

Step 4: Lubricate worm gear assembly on new elevating shaft assembly with spray silicone lubricant, **make sure wave washer, flat washer and quad ring are on lower bearing** and insert assembly in housing.

Step 5: Reinstall plastic plug in top of housing. Gears will mesh automatically once elevating crank is turned.

Step 6: Replace directional handle, spring and elevating crank. Make sure set screw contacts flat surface on shaft before tightening.