

COAX

# Skyliner

U.S. Pat No. 3587104  
Canadian Pat No. 897266

ALL CHANNEL RECREATIONAL VEHICLE ANTENNA FOR  
BLACK & WHITE, COLOR TV. & FM

## SKYLINER INSTALLATION INSTRUCTIONS

NOTE: THE OVERALL LENGTH OF THE SKYLINER ANTENNA WHEN LOWERED IS 60 INCHES.

**CAUTION: DURING INSTALLATION AND USE OF THE ANTENNA, MAKE SURE LEGS AND HEAD CANNOT ACCIDENTALLY COME INTO CONTACT WITH ANY POWER LINE.**

**CONTACT WITH POWER LINES COULD RESULT IN SERIOUS INJURY OR DEATH.**

**WARNING: DO NOT TRAVEL WITH ANTENNA IN RAISED POSITION.**

### Contents

1	Antenna Assembly		1	Travel Support	Part No. 11699
1	Ceiling Plate	Part No. 10302	1	Hex Key	Part No. 80600
3	Cable Clips	Part No. 10323	18	Screws No. 6 x 3/4	Part No. 81000
1	Lead-In Plate	Part No. 10579	3	Screws No. 6 x 3/8	Part No. 81001
2	Lead-In Gaskets	Part No. 10580	3	Screws No. 4 x 3/8	Part No. 81007
1	Co-ax Cable	Part No. 16011	2	Screws No. 10 x 3/4	Part No. 81008
1	Operating Crank	Part No. 10739			

### TOOLS REQUIRED

Electric hand drill	Hacksaw
1/2" drill (long enough to penetrate roof)	Caulking compound (similar to 3M Drip Check Sealer #8543)
1/8" Drill, 3/32 Drill, 5/32 Drill	
Screw drivers (Phillips & straight)	

NOTE: "Pop" rivet gun and 1/8" pop rivets may be used to secure mounting plate to roof if the vehicle roof material is suitable.

After removing antenna from carton, **TURN THE MOUNTING PLATE (12660) CLOCKWISE (LOOKING AT TOP) TO THE STOP BEFORE STARTING TO INSTALL.** Also, make sure UHF dipoles are set in position shown in Fig. 2.

Select a position on the recreational vehicle roof that will allow the Skyliner to (a) lay horizontally at rest, (b) raise fully and rotate fully, and (c) lower without disturbing other roof top equipment, such as, vents and air conditioner, etc. Decide upon the entry of the lead-in cable. In many cases the refrigerator vent provides a convenient and weatherproof entry, but the oven vent is not advised because of the high temperature. Due to the large variations in vehicle construction it is not possible to recommend a particular entry position. (d) It is advisable to overlap a roof stud with the front edge of Mounting Plate (12660). **DO NOT** drill roof stud for drive shaft, (12927) or stud will be weakened.

**CAUTION:** Before proceeding with any drilling, check points (a), (b), and (c) again and note that the turning radius of the antenna base is 7 inches. Having satisfied these requirements, mark the position selected and proceed as follows on page 2.

 **H&H BRAUND** MANUFACTURING COMPANY (CANADA) LIMITED

**INSTALLATION: CAUTION THERE MAY BE WIRING BETWEEN ROOF & CEILING.**

1. At the marked position, drill a pilot hole through roof and ceiling. Keep drill perpendicular to roof — this is important! Misalignment will cause drive shaft to bind on edges of roof or ceiling after installation.
2. Enlarge this hole using a 1/2" drill—keeping it perpendicular while drilling. Clear away any insulation material in hole.
3. If using cable entry provided at front edge of mounting plate (Fig. 1.) see template on page 5 and use it to position 2nd 1/2" hole for the lead wire cable. Note— Some RV manufacturers install lead wire during construction of RV's. For best performance the lead wire must be shielded 75 ohm co-ax cable as we supply.

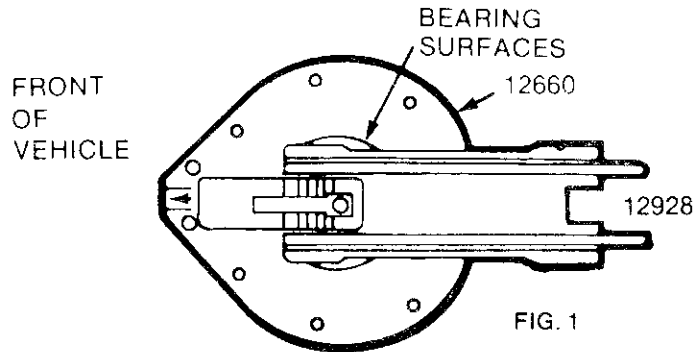

4. Do not caulk mounting plate at this stage, but lower the antenna into position, passing drive shaft down through the 1/2" hole in roof. Mounting plate should look like Fig. 1 when viewed from above. Note: "Front Of Vehicle" direction.
5. Position travel support (11699) as in Fig. 2 so that fully lowered antenna allows mounting plate to rest flush on roof surface. Drill 3/32" holes in roof, apply caulk and screw travel support down using 2 x No. 10 x 3/4 (81008) screws supplied.

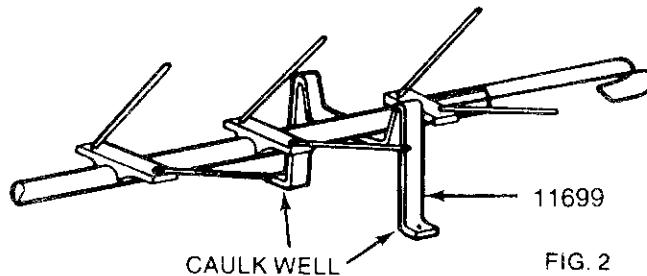

6. Leave antenna in lowered position resting in travel support.
7. Inside RV center the drive shaft (12927) in the ceiling hole and carefully fit the ceiling plate (10302) using 3-4x3/8" (81007) screws or "pop" rivets.
8. Measure and mark the drive shaft as shown in Fig. 3, remove antenna from roof and saw off excess shaft and remove "burr" with a file.
9. Push crank handle (10739) on to shaft and mark shaft by tightening set screw. "Dimple" the shaft at this mark using a drill, so that set screw enters shaft when tight.

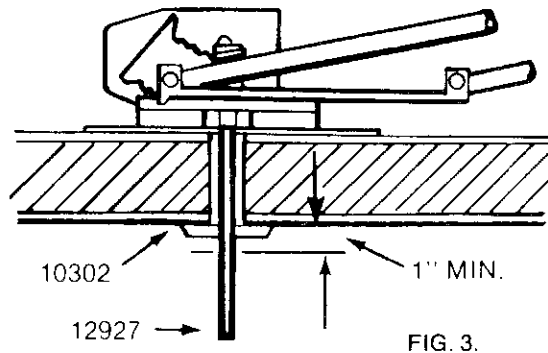

You are now ready to fit antenna to roof. If you intend using screws instead of "pop" rivets, the 14 holes in the mounting plate must be enlarged using 5/32" drill.

10. Caulk underside of mounting plate flange thoroughly and carefully lower drive shaft into roof hole, guiding it into ceiling plate hole. Check positioning (Fig. 1 and paragraph 4) and drill 2 of the 14 fixing holes (1/8" for "pop" rivets and 3/32" for screws). Secure to roof and continue with rest of the holes. Caulk should be visible all round flange of mounting plate. Caulk screw heads or top of "pop" rivets.
11. It is very important that the cable entry (Fig. 1) is thoroughly caulked especially if not used.
12. The crank handle (10739) may now be pushed fully home on to drive shaft and secured by tightening set screw hard with hex wrench. This completes the basic installation and we suggest the following procedures for testing raising, turning and lowering operations:

#### TESTING

1. Raise antenna by pulling crank down and turning it counter-clockwise (looking up to ceiling).
2. When antenna is fully raised TURN CRANK IN OPPOSITE DIRECTION AT LEAST HALF A TURN BEFORE PUSHING IT UP WHILE STILL TURNING SLIGHTLY. See Fig. 5. This will engage the rotate pin.
3. Hold crank as in Fig. 5 and turn it fully COUNTER-CLOCKWISE to the stop. Then return it CLOCKWISE to the stop. If the installation has been correct, the antenna will now be "in-line" and ready for lowering.
4. Pull crank down to disengage rotate pin, then turn crank CLOCKWISE (looking up at ceiling) until resistance is felt and you hear the antenna contact the travel support (11699).

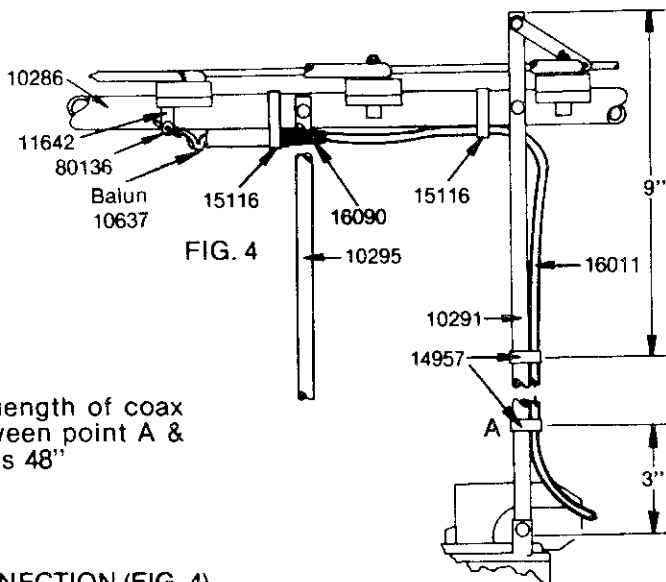

**NOTE**  
Minimum length of coax cable between point A & roof entry is 48"

#### COAX CABLE CONNECTION (FIG. 4)

Place fork terminals of balun between "L" bracket 11642 & wingnut 80136 and tighten. Secure balun (10637) to boom using 15116 cable tie. Secure cable to boom 10286 & leg 10291 using 15116 & 14957 cable ties as shown. When connecting co-ax cable to balun make sure centerwire of co-ax cable connector enters the balun socket without bending and boot 16090 is positioned as shown.

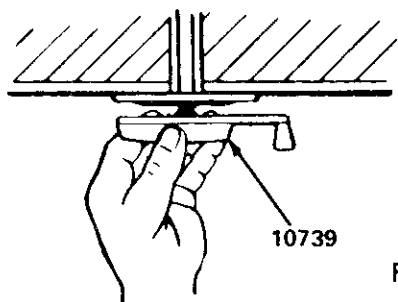

FIG. 5

**NOTE:** To operate a correctly installed antenna FORCE IS NOT REQUIRED. If unit does not work easily—check installation procedures and the information on pages 2 and 3

This completes the mechanical installation and testing of your Skyliner. Lead wire preparation and connections are described next. Check your vehicle literature. Some RV manufacturers install TV lead wire during manufacture.

3. Approximately 4 feet of cable should be "free" between the antenna terminals and (a) the cable entry on the mounting plate (12660) or (b) the clamp or "gland" ( 10579/10580 Fig. 7), whichever method is used.
4. Fig. 7A shows 10579/10580 being used as a cable entry gland. Fig. 7B shows 10579/10580 being used as a cable clamp. Their position on the roof should be not less than 8" from the center of mounting plate (12660). Use plenty of caulking.
5. Use plastic cable clips (10323) and NO. 6 x 3/8 screws (81001) wherever needed to secure cable to roof.
6. If two wall jacks are required it is ESSENTIAL to use a special coupler or amplifier. These are available from Braund Manufacturing either non-amplified (2-Set Coupler, 15250, 15251, 15252, 15253) or amplified ("Power Plus" Booster Amplifier, 13878, 13879, 13880, 13881). Send for brochures.
7. Carry out the testing procedure described on Page 3 to make certain that the lead wire cable does not catch on any obstructions during the complete cycle of operations.

FIG. 7A Used as a cable entry gland.

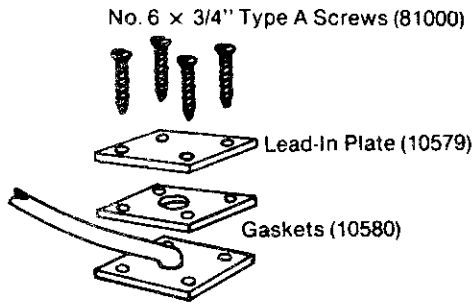
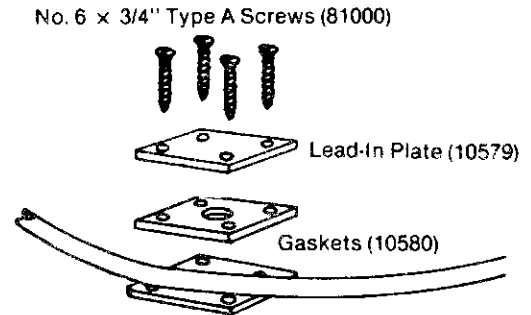
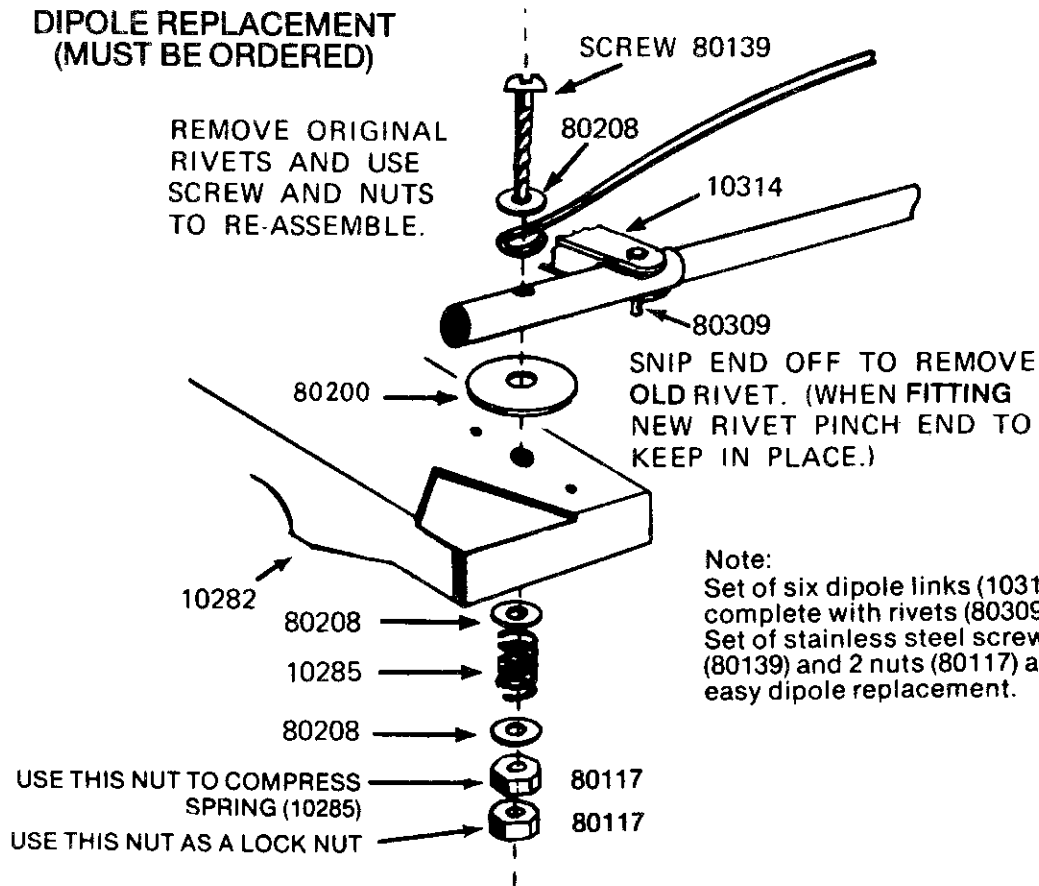

FIG. 7B Used as a cable clamp.



**DIPOLE REPLACEMENT  
(MUST BE ORDERED)**

REMOVE ORIGINAL RIVETS AND USE SCREW AND NUTS TO RE-ASSEMBLE.



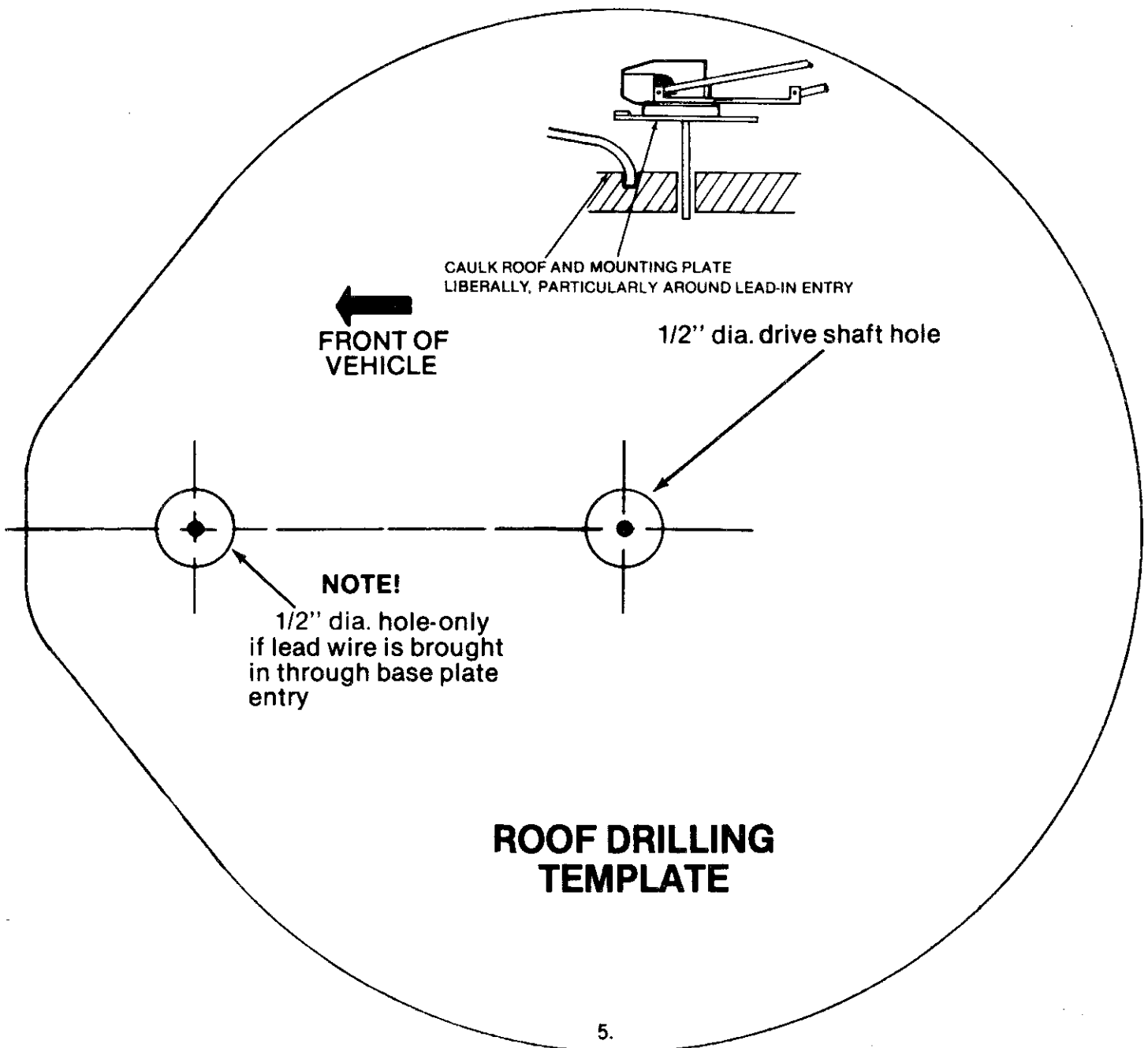
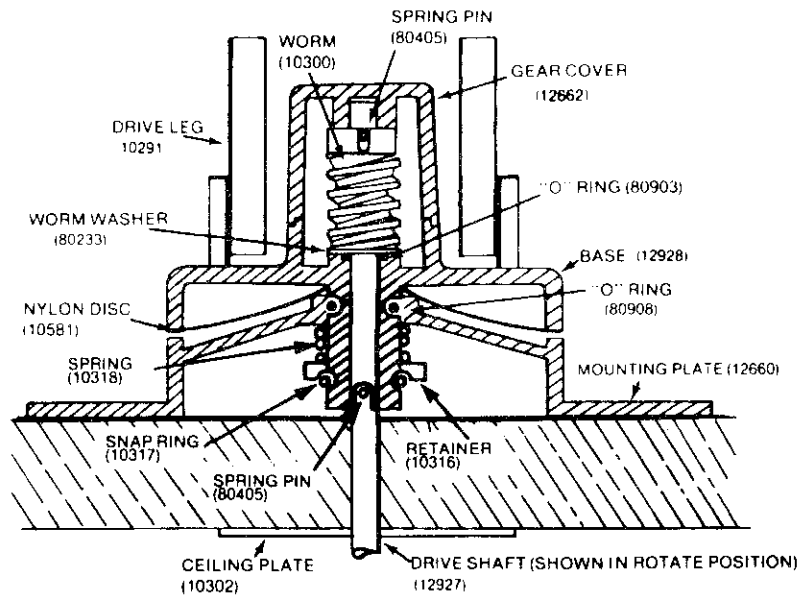

# PARTS LIST

Part No.	Description	Part No.	Description		
2	10272	VHF DIPOLE 49 $\frac{3}{4}$	1	11699	TRAVEL SUPPORT
2	10273	VHF DIPOLE 40 $\frac{3}{4}$	2	11642	"L" BRACKET
2	10274	VHF DIPOLE 30 $\frac{3}{4}$	2	11708	OPERATING LINK
6	10275	UHF DIPOLE 7 $\frac{1}{2}$	1	11789	AUTHORIZED SERVICE CENTERS
2	10276	UHF DIPOLE 5	2	11972	PHASE WIRE INSULATOR
1	10277	PHASE STUB	1	12394	DRIVE AXLE
4	10278	PHASE WIRE 14 $\frac{3}{4}$	1	12395	IDLER AXLE
1	10279	PHASE WIRE 7 $\frac{1}{4}$ SINGLE BEND	1	12399	DIPOLE WARNING CARD
2	10280	PHASE BAR	1	12660	MOUNTING PLATE
2	10281	END PLUG	1	12662	COVER
7	10282	INSULATOR BLOCK	1	12927	DRIVE SHAFT
6	10284	OVERSERT	1	12923	BASE
6	10285	SPRING	2	14957	CABLE TIE
1	10286	BOOM	2	15116	CABLE TIE
1	10287	OPERATING TUBE	1	15246	CO-AX TV OUTLET
2	10291	DRIVE LEG	1	16011	CO-AX CABLE ASSEMBLY
4	10292	BOOM BUSHING	1	16090	BOOT
1	10294	WORM GEAR	1	80004	LOCK RING $\frac{3}{8}$
2	10295	IDLER LEG	1	80005	LOCK RING $\frac{1}{4}$
1	10300	WORM	2	80115	NO.10-24 x $\frac{1}{2}$ R.H.M.S.
1	10302	CEILING PLATE	2	80136	WING NUT
1	10313	WARRANTY CARD	6	80200	NYLON WASHER
6	10314	DIPOLE LINK	28	80208	WASHER ALUMINUM $\frac{3}{8}$
1	10316	RETAINER	6	80209	WASHER ALUMINUM
1	10317	SNAP RING	1	80233	WORM WASHER
1	10318	SPRING	2	80307	RIVET, LEG TO BOOM
3	10323	E-4 CABLE CLAMPS	12	80309	RIVET, LINK TO
1	10512	DRIVE PIN	8	80313	RIVET
1	10579	LEAD-IN PLATE	13	80319	RIVET
2	10580	LEAD-IN GASKET	2	80405	SPRING PIN
1	10581	NYLON DISC	1	80600	HEX KEY
1	10637	BALUN	1	80903	"O" RING
1	10731	PHASE WIRE 7 $\frac{1}{4}$ DOUBLE BEND	1	80908	"O" RING
1	10739	CRANK HANDLE ASSEMBLY	18	81000	SCREW (6 x $\frac{3}{4}$ FOR 12660 & 10579)
2	11078	SIDE CLOSURE	3	81001	SCREW 6 x $\frac{3}{8}$
2	11079	ROTATING CLOSURE	3	81007	SCREW 4 x $\frac{3}{8}$ FOR 10302
2	11080	SPACER	2	81008	SCREW 10 x $\frac{3}{4}$ FOR 10305
8	11607	DIPOLE CLAMP	2	81033	SCREW 8 x $\frac{1}{2}$ FOR 12662
			1	82306	SPACER

If replacement parts should be required, you may order them from your dealer or direct from Braund Mfg. Co., 730 East Michigan Ave., Battle Creek, Michigan 49016. For an up-to-date price list, write to the above address and specify your model antenna.

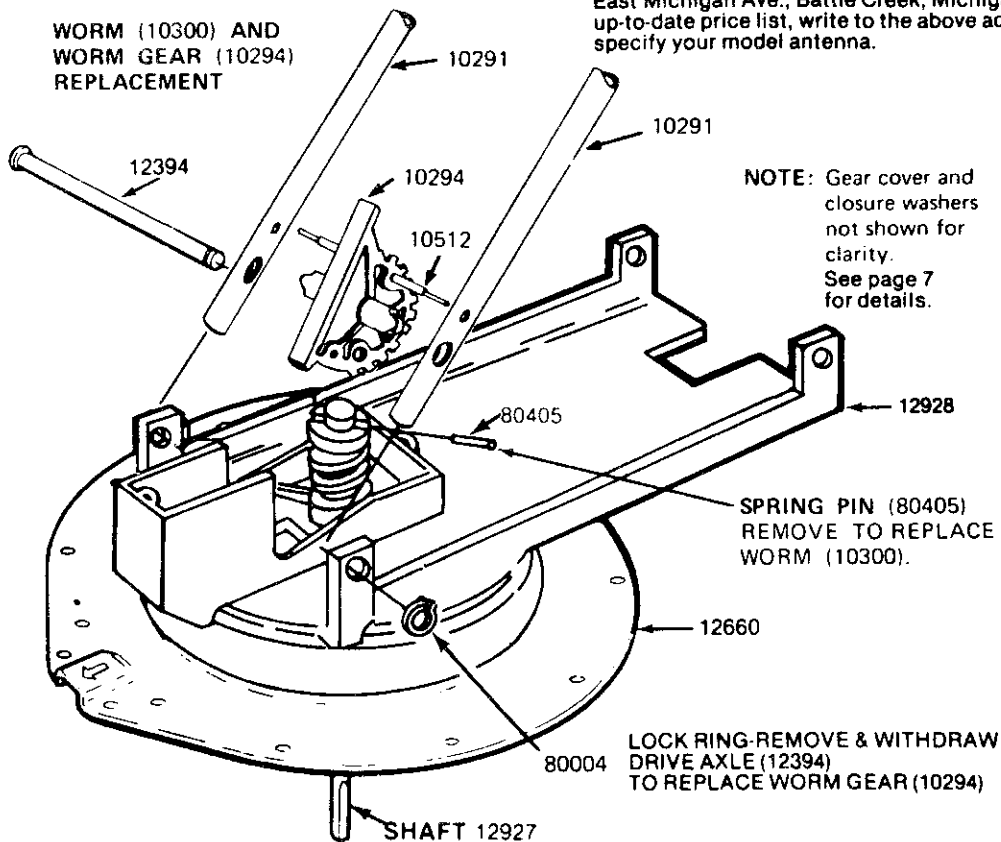

# EXPLODED VIEW OF COAX SKYLINER ANTENNA

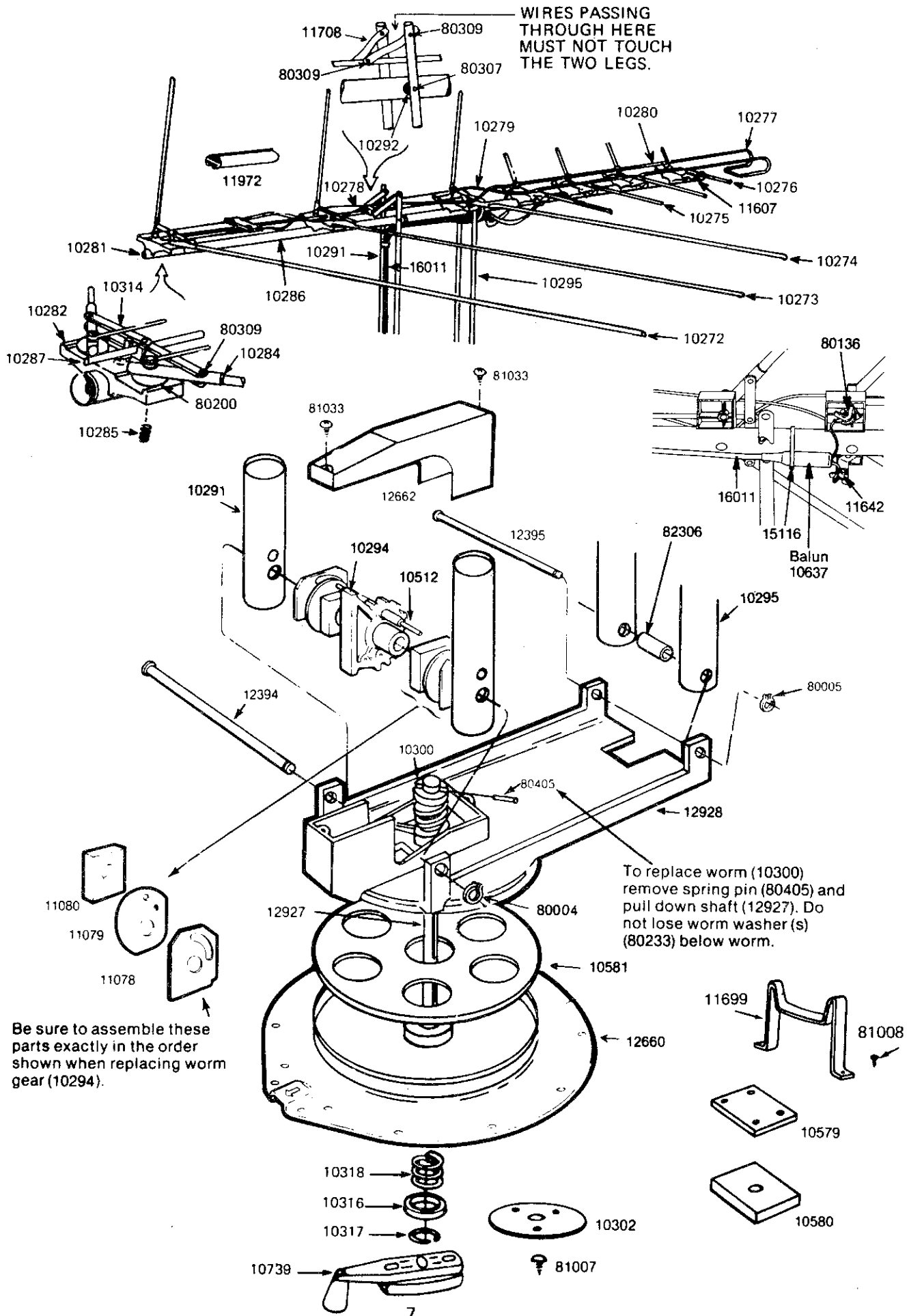

## PROBLEMS & REMEDIES

### **DIFFICULT TO PUSH HANDLE UP & DOWN**

(a) After raising the antenna always "back off" the crank handle in the opposite direction about half a turn before pushing up to the rotate position.

(b) It is very important that there is no sideways pressure on the shaft when the ceiling plate (10302) is fitted. To check this raise antenna, remove the ceiling plate and refit crank handle. The shaft should move up and down with little effort. Before refitting ceiling plate, enlarge the ceiling hole so that the plate will fit flush to ceiling without putting any stress on the shaft. Also check that glass fiber insulation is not fouling the shaft.

(c) The shaft may have been cut too short during installation thus preventing up and down movement. The only remedy is to replace the shaft. Remove pin (80405) which passes through the slot in top of worm (10300). Shaft (12927) may then be withdrawn downward after removing the ceiling plate (10302). The new shaft should be checked for "burrs" and coated with silicone grease before fitting. Use a twisting motion when inserting the new shaft to avoid damage to the "O" ring (80903) positioned just below the worm (10300).

### **DIFFICULT TO ROTATE**

(a) The most common cause is excessive caulking around the base and mounting plate causing binding. In extreme cases it will be impossible to turn the antenna usually resulting in breakage of the crank handle (10739). Check that the bearing surfaces of the base (12928) and mounting plate (12660) are clear of caulking or sealing material.

(b) If the co-ax cable (16011) is too short (less than 4 feet) it may prevent full rotation, or if too long the loop may catch on some other roof top device such as a vent.

(c) The antenna may have been installed too close to a vent or air conditioner with insufficient clearance for the base to rotate fully.

### **ANTENNA WILL NOT RAISE**

(a) Usually caused by a stripped worm gear (10294) and/or worm (10300). Gears are usually damaged by (1) trying to raise the antenna by turning the crank in the wrong direction. (2) With the antenna raised a heavy blow on the antenna head from a tree limb will strip either or both gears. For this reason we do advise against driving with the antenna in the raised position. A new worm gear (10294) is easily replaced after removing the gear cover (12662) and withdrawing the drive axle (12394). The worm (10300) may be replaced by removing pin (80405) at top of worm and then partly withdrawing the shaft (12927) downwards until it is clear of the worm. Damaged worm may then be removed and replaced - caution - do not lose the worm washer (80233) which is positioned just below the worm.

All of the above work may be carried out without removing the unit from the vehicle. However, any damage to the base (12928) or plate (12660) will require removal from the roof.

### **RECEPTION**

Due to the various locations used by recreational vehicles, reception will not be so consistent as at a fixed location because of the large variation in the terrain encountered throughout the country. In general TV/FM signals (particularly UHF) travel roughly in a straight line so hills or mountains etc. between your vehicle and the transmitting station may severely reduce the amount of signal reaching your antenna.

When more than one TV outlet jack is used in a vehicle it is ESSENTIAL to use a splitter device - (this is incorporated in the Braund "Power Plus" Booster Amplifiers or 2-set Couplers) to avoid reduction in picture strength and quality.

### **MAINTENANCE**

All exposed moving parts should be lubricated every 3 months using a spray lubricant similar to WD40 or a silicone spray. Every year, lift the gear cover with antenna raised and check the grease. Replace if necessary using lubriplate 630AA or similar grease. When replacing cover see that the side closures (11078) are inside the sides of the cover.



## INSTALLATION OF BOOSTER AMPLIFIER

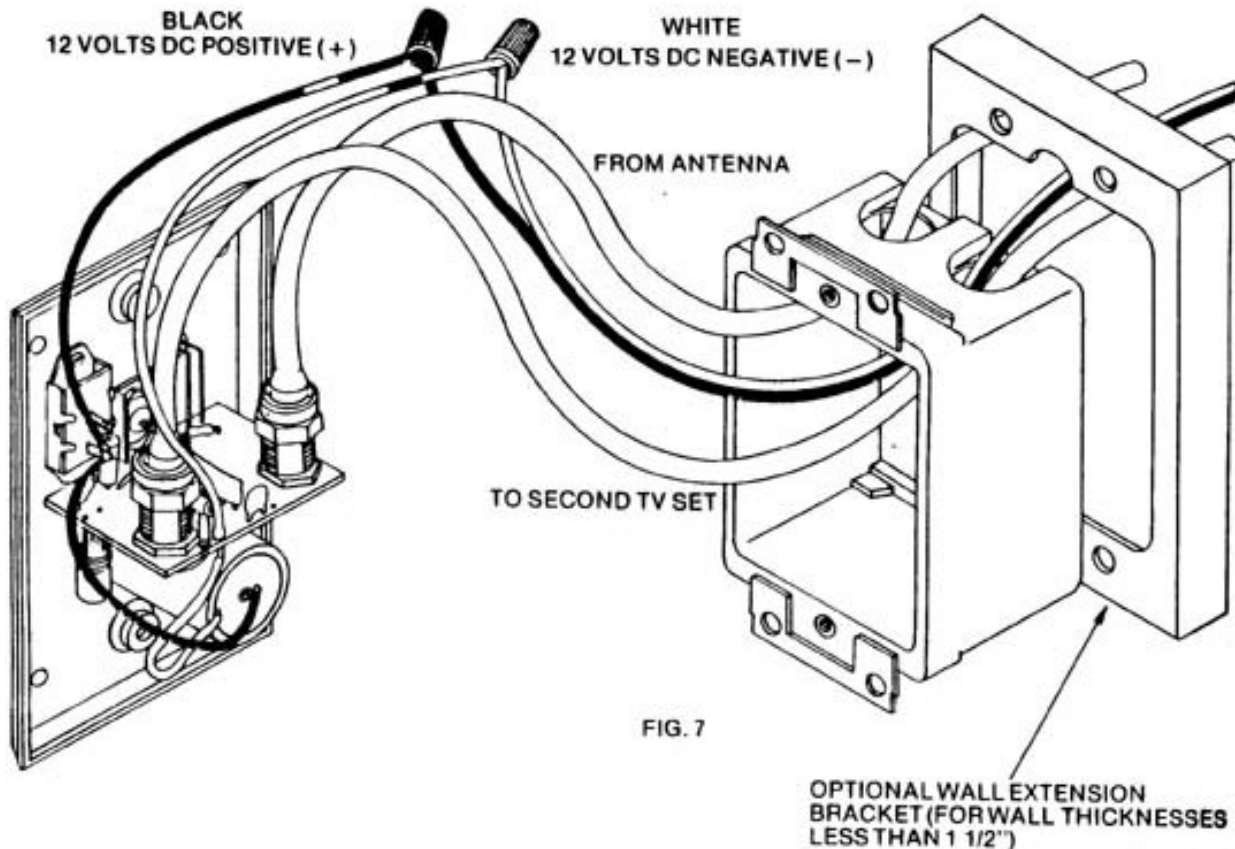

FIG. 7

OPTIONAL WALL EXTENSION BRACKET (FOR WALL THICKNESSES LESS THAN 1 1/2")

- 1- Remove any existing wall jack and modify hole size if necessary.
- 2- Remove protective box from amplifier and feed the antenna co-ax cable and connector through the correct hole as shown in FIG. 7.
- 3- Do the same with the cable which goes to the extra wall jack (if installed).
- 4- **Important note:** if the wall thickness of your vehicle is less than 1 1/2" use the optional wall extension bracket (supplied) and lead all cables and wire through it also. **Make sure you screw the cables onto the correct sockets on the amplifier exactly as shown.**
- 5- It is **essential** that the 12 volt DC supply comes from the battery side of the converter. To confirm this, disconnect the RV from any outside 110 volt AC supply.
- 6- Wire the **black** lead of the amplifier to 12 volts DC **positive (+)** and the **white** lead to 12 volts DC **negative (-)** using the wire nuts supplied. **Incorrect polarity will damage the unit and void the warranty.**
- 7- Screw the box to the wall and replace amplifier panel.
- 8- Use the 4' coax cable supplied with the VHF/UHF splitter (part no. 15158) to connect the amplifier to your TV set. The splitter may have to be used depending on the input connections on your particular TV. A range of splitters is available- send for our catalog.
- 9- Using the amplifier- with the switch "up" the red lamp will light and the amplifier will be on. It should be noted that if you are very close to a TV station there may be some "distortion" of the picture- results may be obtained with the amplifier switched off. Switch off when not in use.

## PROBLEMS & REMEDIES:

### DIFFICULT TO PUSH HANDLE UP & DOWN:

(a) After raising the antenna always "back off" the crank handle in the opposite direction about half a turn before pushing up to the rotate position.

(b) It is very important that there is no sideways pressure on the shaft when the ceiling plate (10302) is fitted. To check this raise antenna, remove the ceiling plate and refit crank handle. The shaft should move up and down with little effort. Before refitting ceiling plate, enlarge the ceiling hole so that the plate will fit flush to ceiling without putting any stress on the shaft. Also check that glass fiber insulation is not fouling the shaft,

(c) The shaft may have been cut during installation thus preventing up and down movement. The only remedy is to replace the shaft. Remove pin (80405) which passes through the slot in top of worm (10300). Shaft (12927) may then be withdrawn downward after removing the ceiling plate (10302). The new shaft should be checked for "burrs" and coated with silicone grease before fitting. Use a twisting motion when inserting the new shaft to avoid damage to the O-ring (80903) positioned just below the worm (10300)

### DIFFICULT TO ROTATE:

(a) If the coax cable is too short (less than 48") it may prevent full rotation, or if too long the loop may catch on some other roof top device such as a vent.

(b) The antenna may have been installed too close to a vent or air conditioner with insufficient clearance for the base to rotate fully.

### ANTENNA WILL NOT RAISE (SEE FIG.1):

Usually caused by a stripped worm gear (10294) and/or worm (10300). Gears are usually damaged by (1) trying to raise the antenna by turning the crank in the wrong direction. (2) With the antenna raised a heavy blow on the antenna head from a tree limb will strip either or both gears. For this reason we do advise against driving with the antenna in the raised positions. A new worm gear (10294) is easily replaced after removing the gear cover (12662) and withdrawing the drive axle (12394). The worm (10300) may be replaced by removing pin (80405) at top of worm and then partly withdrawing the shaft (12927) downwards until it is clear of the worm. Damaged worm may then be removed and replaced - caution - do not lose the worm washer (80233) which is positioned just below the worm. All of the above work may be carried out without removing the unit from the vehicle. However, any damage to the base (12928) or plate (12660) will require removal from the roof.

### RECEPTION:

Due to the various locations used by recreational vehicles, reception will not be so consistent as at a fixed location because of the large variation in the terrain encountered throughout the country. In general TV/FM signals (particularly UHF) travel roughly in a straight line so hills or mountains etc; between your vehicle and the transmitting station may severely reduce the amount of signal reaching your antenna.

### MAINTENANCE:

All exposed moving parts should be lubricated every 3 months using a spray lubricant similar to WD40 or a silicone spray. Every year, lift the gear cover with antenna raised and check the grease. Replace it necessary using our "Super Lube" or similar grease. When replacing cover see that the side closures (111078) are inside the sides of the cover.