



**OPERATION AND MAINTENANCE INSTRUCTIONS
FOR 8000 SERIES
ROOF TOP AIR CONDITIONERS
AND
CEILING PLENUMS**

**MODE D'EMPLOI ET UTILISATION
DES CLIMATISEURS DE TOIT DES
SÉRIES 8000 ET
PLÉNUM DE PLAFOND**

**RV Products
A Division of Airxcel, Inc.
P.O. Box 4020
Wichita, KS 67204**

TABLE OF CONTENTS

| | | |
|-------------|---|----------|
| I. | General Information | 2 |
| II. | Standard Ceiling Plenum Control Panel | 2 |
| III. | Standard Ceiling Plenum Operation | 3 |
| IV. | Maintenance | 4 |
| V. | Wall Thermostat Identification And Operation | 6 |
| VI. | Warranty Service | 7 |

SECTION I - GENERAL INFORMATION

These air conditioners were designed to operate from a 115 VAC, 60 HZ, 1 Phase power supply. Anytime an air conditioner is not operating properly, the power supply should be examined by a qualified technician to verify that the air conditioner is receiving the proper power supply.

The ability of the air conditioner to maintain the desired inside temperature depends on the heat gain of the recreational vehicle.

The size of the vehicle, amount of window area, amount of insulation, direct exposure to the sun, outside temperature and the number of people in the recreational vehicle may increase the heat gain to such an extent that the capacity of the air conditioner is exceeded.

As a general rule, air entering the air conditioner will be cooled about 15 to 20 degrees, depending on the outside temperature and humidity conditions.

For example, if the air entering the return air grilles in the air conditioner is 80 degrees F, the air leaving the discharge grilles in the air conditioner will be 60 to 65 degrees F.

As long as this temperature difference is being maintained between the return air and discharge air, the air conditioner is operating at its capacity. If the desired inside temperature (normally 80 degrees F) cannot be maintained, then the heat gain of the RV is too great for the capacity of the air conditioner.

Parking the vehicle in a shaded area, keeping windows and doors shut and avoiding the use of heat producing appliances in the vehicle will help to reduce the heat gain. When possible, the addition of insulation and tinted glass (especially in uninsulated vans) should be considered.

NOTE

The optional Elect-A-Heat heating assembly is intended to take the chill out of the indoor air when the air is a few degrees too cool for comfort. The heating assembly is an effective “chill chaser”. It is not a substitute for a furnace.

SECTION II - CONTROL PANEL

If your RV air conditioner is operated from the control panel located in the ceiling assembly, then there are three controls on the ceiling assembly that help you control the air conditioner. They are as follows:

A. The Selector Switch - The selector switch determines which mode of operation the air conditioner will be in. By rotating the selector switch, the operator can obtain any system function desired. System functions vary depending upon options of both the roof top unit and ceiling assembly. Figure 1 shows selector switch location and lists all available functions by model.

The “Operation” section explains the operational characteristics of each mode of operation.

B. The Thermostat (temperature control) - In the cooling mode, the thermostat regulates the “ON” and “OFF” temperature setting at which the compressor will operate.

For “Heat/Cool” models, the thermostat also controls the “ON” and “OFF” temperature settings of the heater assembly. See Figure 1.

C. Louvers - The louvers are located at both ends of the ceiling assembly shroud and are used in directing the discharge air from the unit.

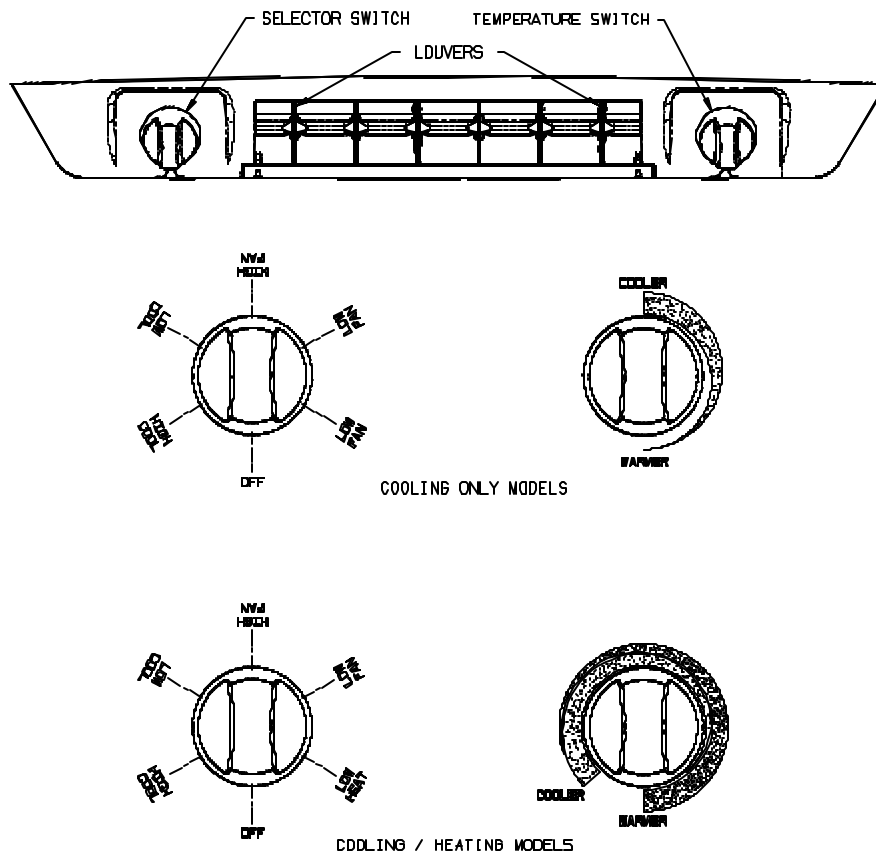

FIGURE 1

SECTION III - OPERATION

I. For Cooling (Refer to Figure 1, page 3).

- A. Turn the selector switch to the “LOW COOL” or “HIGH COOL” position.
- B. Rotate the thermostat (temperature control) to the position that is the most comfortable to you. The thermostat will turn the compressor on when the temperature of the air entering the air conditioner rises a few degrees above the setting you have selected. Then the temperature of the air entering continues to cycle the compressor on and off in the above mentioned fashion until the selector switch is turned to another mode of operation.
- C. Position the louvers to the desired direction the discharge air is to flow.

Note: The fan operation is constant, only the compressor cycles on the thermostat.

II. Operation During Cooler Nights (Cooling Operation).

It is important, when the outdoor temperature drops in the evening or during the night to below 75 degrees F, that the thermostat (temperature control) be set at a midpoint between “Warmer” and “Cooler”. If the setting is at “Cooler”, the evaporator coil may become iced-up and stop cooling. During the day when the temperatures have risen above 75 degrees F, reset the thermostat switch to the desired setting.

NOTE

Should icing-up occur, it is necessary to let the cooling (evaporator) coil defrost before normal cooling operation is resumed. During this time, operate the unit in the “HIGH FAN” position with the system at maximum air flow. When

increased or full air flow is observed, the cooling coil should be clear of ice.

III. Short Cycling

When an air conditioner is in operation, its compressor circulates refrigerant under high pressure. Once off, it will take two to three minutes for this high pressure to equalize.

The air conditioning compressor is unable to start against high pressure. Therefore, once the air conditioner is turned off, it is important to leave it off for two to three minutes before restarting.

Short cycling the compressor (or starting it before pressures have equalized), will in some instances, kick the circuit breaker or overload.

IV. For Heating (“Elect-A-Heat” Ceiling Assembly Model Only) Refer To Figure 1, page 3).

The optional Elect-A-Heat heating assembly is intended to take the chill out of the indoor air when the air is a few degrees too cool for comfort. The heating assembly is an effective “chill chaser”. It is not a substitute for a furnace.

Do not expect the heating coil on your heater to glow. Because the fan draws in cold air and forces it over the coil, the coil will not turn red. A hint of red may occur where the moving air does not directly touch the coil.

- A. Turn the selector switch to the “LOW HEAT” position. At “LOW HEAT”, the fan operates on low speed with heat output at maximum.
- B. Rotate the thermostat (temperature control) switch to the position that is the most comfortable to you. The thermostat will turn the heater on when the

temperature of the air entering the air conditioning unit drops below this setting a few degrees and automatically turns off when the temperature of the air entering the air conditioner rises a few degrees above this setting. The heater will continue to cycle on and off in this fashion until the selector switch is turned to another mode of operation.

- C. Position the louvers to the desired direction the discharge air is to flow.

Discharge air temperature can be controlled to some extent by opening or closing the louvers.

When the louvers are closed, the warmest localized discharge air is achieved. Fully opened louvers will throw the warm discharge air to the back and front of the vehicle for more efficient circulation and faster warm-up. Although the air temperature is lower with the louvers fully opened, the heating capacity is still the same.

V. For Air Circulation Only (Refer To Figure 1, page 3).

- A. Turn the selector switch for “LOW FAN” or for maximum air flow, to “HIGH FAN”.
- B. Position the louvers to the desired direction the discharge air is to flow.

NOTE

When the selector switch is in the “LOW FAN” or “HIGH FAN” position, the blower motor will operate continuously.

SECTION IV - MAINTENANCE

1. Owner

One of the biggest advantages to your new RV Products air conditioner is that the maintenance needed to keep the unit in good care is minimal. In fact about the only thing you, the owner, must take care of is the cleaning and replacement of the filters.

Filters are made from long life non-allergenic natural fibers which can be cleaned and reused, and which completely filter the circulated air when the air conditioner is in operation. If the filters are not cleaned at regular intervals, they may become partially clogged with lint, dirt, grease, etc. A clogged filter will produce a loss of air volume and may eventually cause an icing-up of the cooling (evaporator) coil.

IMPORTANT

Do not operate your air conditioner for extended periods of time without the filter installed.

An even more serious condition occurs when the air conditioner is operated without a filter. When this happens the lint, dirt, grease, etc. that are normally stopped by the filter are now accumulating in the cooling coil. This not only leads to a loss of air volume and a possible icing-up of the cooling coil, but could also result in serious damage to the operating components of the air conditioner.

We recommend that the filters be cleaned and changed at least every two weeks when the air conditioner is in operation.

Cleaning and/or changing the filters:

1. Disengage the two 1/4-turn fasteners that secure the ceiling assembly grille to the ceiling assembly (See Figure 2).
2. Lower the grille and filters from the ceiling assembly.
3. Take filters out and either clean or exchange with other filters (See Figure 2).
4. If the vehicle is equipped with a flush mount ceiling assembly, remove the four return air grill screws. Remove filter from grill and either clean or exchange with new filters.

NOTE

If replacement filters are necessary, the filters can be purchased from most RV Products Authorized Service Centers. It is recommended that spare filters be carried with the RV at all times to replace worn, torn or deteriorated filters.

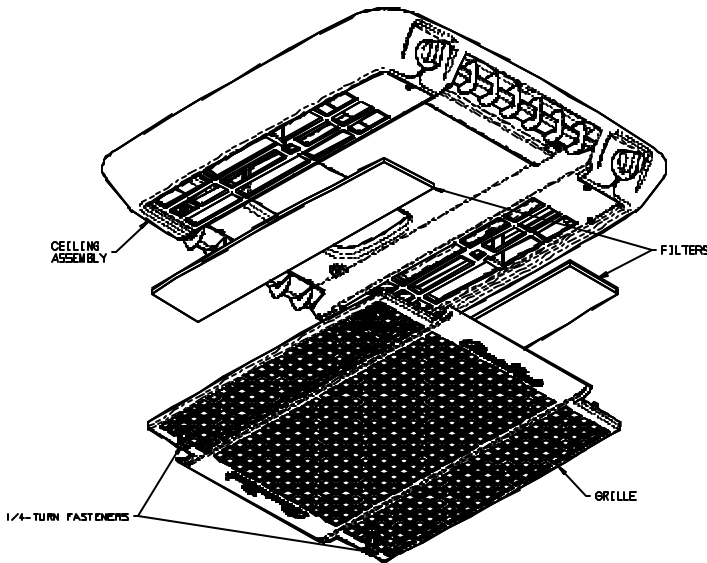

FIGURE 2

II. Service Person

- A. Electrical - All electrical work and/or inspection should be performed only by qualified service personnel. Contact your nearest RV Products Service Center if electrical problems should arise.
- B. Check Points - Failure to start or to cool the air are sometimes problems with air conditioning units. The RV Products RV air conditioner is designed to operate on 115 volt electrical power. If the compressor on the air conditioner fails to start, check

with your RV Products Service Center to determine that the proper wire size is connected to the unit, the proper circuit breakers are installed as protection devices on the electrical circuit and the proper sized extension cord is being used for the distance covered from the utility outlet to the RV. The required minimum wire size is #12 AWG for lengths up to 25 feet (larger wire size for greater distances). Each air conditioning unit must be protected with a 20 amp time delay fuse or circuit breaker.

If the air conditioner continues to trip off the circuit breakers, have an electrician check the starting amperage and running amperage on the unit. If the circuit breaker continues to trip off and the electrical consumption is found to be normal, it will require the replacement of the faulty circuit breaker.

If all electrical power to the air conditioner is normal but neither the fan or the compressor will operate, the connector plug located behind the ceiling assembly control box should be checked to determine whether it is faulty.

On the heating-cooling air conditioner models, if all electrical power to the unit is normal and the fan runs but you never get any heated air, then the electrical plug to the heating unit should be checked for a secure connection. If this does not correct the malfunction, the heating thermostat or limit switch may be faulty.

- C. Mechanical Integrity - The air conditioner should be inspected periodically to be sure that the bolts which secure the unit to the roof are tight and in good shape. Also, an examination of the plastic shroud covering the air conditioner on the top of the roof should be made periodically. Be sure the four mounting screws and washers are snug and holding the shroud to the air conditioner. Also examine the shroud to be sure it is not developing cracks or has suffered damage from impact.
- D. Lubrication

DANGER

DISCONNECT THE POWER SUPPLY TO THE UNIT BEFORE SERVICING TO PREVENT A SHOCK HAZARD OR POSSIBLE INJURY FROM MOVING PARTS.

The blower drive motor on some units may include oiling cups at the top of the motor. There is no requirement to oil the journals under normal operating conditions. However, if lubrication to the unit is desired, use only SAE 20 non-detergent type oil. DO NOT OVER OIL - three to four drops in each oil hole once a year is sufficient.

SECTION V - WALL THERMOSTAT IDENTIFICATION AND OPERATION

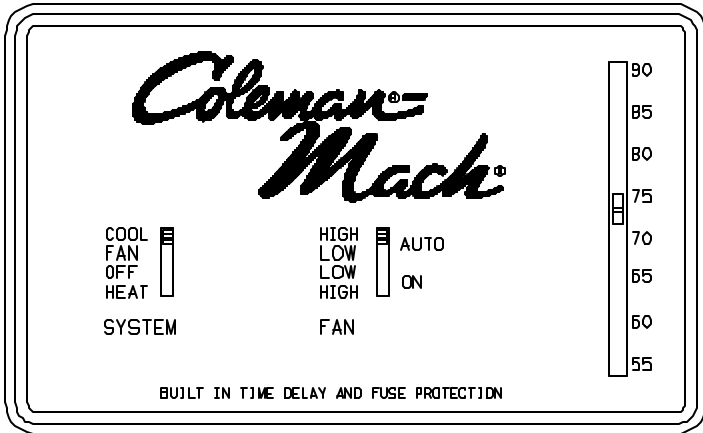
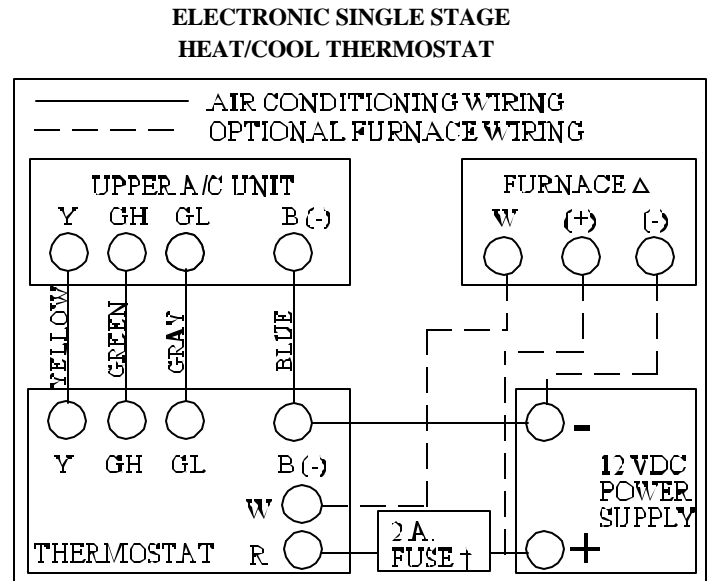

FIGURE 3

Heat/Cool Thermostat Shown.

**“Cool Only” Model Has No Reference
To Heat On Face Of Thermostat.**



† Suggested Fuse To Protect Wiring Leading To Thermostat
 Δ Not Found In “Cool Only” Applications

FIGURE 4

OPERATION

The chart below shows the system functions with the “Heat/Cool” thermostat. After the entire air conditioning system (and furnace system) is installed, check each position function. Disregard references to heat functions when using the “Cool Only” thermostat.

| SHOWS POSITION OF SWITCH | | | | | | | | OPERATION |
|-------------------------------------|-------------------------------------|-------------------------------------|-------------------------------------|-------------------------------------|-------------------------------------|-------------------------------------|-------------------------------------|--|
| SYSTEM | | | | FAN | | | | |
| * HEAT | COOL | OFF | FAN | AUTO HI | LO | LO | ON HI | |
| <input type="checkbox"/> | <input type="checkbox"/> | <input checked="" type="checkbox"/> | <input type="checkbox"/> | <input type="checkbox"/> | <input type="checkbox"/> | <input type="checkbox"/> | <input type="checkbox"/> | No functions occur. |
| <input type="checkbox"/> | <input type="checkbox"/> | <input type="checkbox"/> | <input checked="" type="checkbox"/> | <input type="checkbox"/> | <input type="checkbox"/> | <input type="checkbox"/> | <input type="checkbox"/> | Air conditioner fan runs at high speed continuously regardless of fan switch setting or setpoint. No other functions occur. |
| <input type="checkbox"/> | <input checked="" type="checkbox"/> | <input type="checkbox"/> | <input type="checkbox"/> | <input checked="" type="checkbox"/> | <input type="checkbox"/> | <input type="checkbox"/> | <input type="checkbox"/> | Air conditioner compressor and high speed fan cycle to satisfy setpoint. |
| <input type="checkbox"/> | <input checked="" type="checkbox"/> | <input type="checkbox"/> | <input type="checkbox"/> | <input type="checkbox"/> | <input checked="" type="checkbox"/> | <input type="checkbox"/> | <input type="checkbox"/> | Air conditioner compressor and low speed fan cycle to satisfy setpoint. |
| <input type="checkbox"/> | <input checked="" type="checkbox"/> | <input type="checkbox"/> | <input type="checkbox"/> | <input type="checkbox"/> | <input type="checkbox"/> | <input checked="" type="checkbox"/> | <input type="checkbox"/> | Air conditioner compressor cycles to satisfy setpoint. Air conditioner low speed fan runs continuously. |
| <input type="checkbox"/> | <input checked="" type="checkbox"/> | <input type="checkbox"/> | <input type="checkbox"/> | <input type="checkbox"/> | <input type="checkbox"/> | <input type="checkbox"/> | <input checked="" type="checkbox"/> | Air conditioner compressor cycles to satisfy setpoint. Air conditioner high speed fan runs continuously. |
| <input checked="" type="checkbox"/> | * | <input type="checkbox"/> | <input type="checkbox"/> | <input checked="" type="checkbox"/> | <input type="checkbox"/> | <input type="checkbox"/> | <input type="checkbox"/> | Furnace and furnace blower cycles to satisfy setpoint. Furnace blower operates from sequencer or time delay in furnace. Air conditioner blower does not run. |
| <input checked="" type="checkbox"/> | * | <input type="checkbox"/> | <input type="checkbox"/> | <input type="checkbox"/> | <input checked="" type="checkbox"/> | <input type="checkbox"/> | <input type="checkbox"/> | |
| <input checked="" type="checkbox"/> | * | <input type="checkbox"/> | <input type="checkbox"/> | <input type="checkbox"/> | <input type="checkbox"/> | <input checked="" type="checkbox"/> | <input type="checkbox"/> | |
| <input checked="" type="checkbox"/> | * | <input type="checkbox"/> | <input type="checkbox"/> | <input type="checkbox"/> | <input type="checkbox"/> | <input type="checkbox"/> | <input checked="" type="checkbox"/> | |

All cooling functions controlling to setpoint have a short cycle protection time delay of 3 minutes. There will be no delay if the cycle **OFF** time exceeds 3 minutes.

* There is no heat switch or furnace function available with the “Cool Only” thermostat.

SECTION VI - WARRANTY SERVICE

Let’s face it. Sometimes even the best products may need service. To obtain warranty service on your RV Products air conditioner, please contact your selling dealer, or you may access our web site on the Internet at www.rvcomfort.com for answers to the most frequently asked questions and service center locations.

RV Products support help may be accessed by E-mail at RVPSupport@Airxcel.com.

All written correspondence should be directed to:

RV Products
A Division of Airxcel, Inc.
P.O. Box 4020
Wichita, KS 67204

IMPORTANT

1. Carefully read your limited two year product warranty which is packed with the product.
2. An optional three year extended parts only contract is available at an additional cost of \$89.95. To obtain this optional three years parts contract, fill out the application card stapled to the front of this envelope. Please mail the card and a check or money order to the address above. Applications must be made **within ninety (90) days** of the original purchase.
3. Inquiries about your RV Products air conditioner must include the model and serial numbers and the date of purchase. The model and serial numbers can be found on the I.D. label located on the air conditioner basepan return air opening at the bottom of the roof unit. This information may also be found on the air conditioner rating plate.