



SERVICE MANUAL

FOR

7535, 8534, 8535 SERIES

HEAT PUMPS

TABLE OF CONTENTS

I.	Warnings	3
II.	Unit Specifications	4
III.	Heat Pump Operation With 7530-716 Or 8530-715 Standard Ceiling Assemblies	5
IV.	Wall Thermostat Specifications And Heat Pump Operations With 7530-736 Or 8530-735 Ducted Plenums	7
V.	Basic Components And Their Functions	9
VI.	The Heat Pump Refrigeration Cycle	11
VII.	General Electrical Operational Information	12
VIII.	Service Problems And Possible Solutions	13
IX.	Individual Electrical Component Checkouts	14
X.	Wiring Diagrams	20

I. WARNINGS

IMPORTANT NOTICE

These instructions are for the use of qualified individuals specially trained and experienced in installation of this type equipment and related system components.

Installation and service personnel are required by some states to be licensed. PERSONS NOT QUALIFIED SHALL NOT SERVICE THIS EQUIPMENT.

WARNING

Improper installation may damage equipment, can create a hazard and will void the warranty.

The use of components not tested in combination with these units will void the warranty, may make the equipment in violation of state codes, may create a hazard and may ruin the equipment.

WARNING - SHOCK HAZARD

To prevent the possibility of severe personal injury or equipment damage due to electrical shock, always be sure the electrical power to the appliance is disconnected.

CAREFULLY FOLLOW ALL INSTRUCTIONS AND WARNINGS IN THIS BOOKLET TO AVOID DAMAGE TO THE EQUIPMENT, PERSONAL INJURY OR FIRE.

NOTE

The words "Shall" or "Must" indicate a requirement which is essential to satisfactory and safe product performance.

The words "Should" or "May" indicate a recommendation which is not essential and not required, but which may be useful or helpful.

UNIT MODEL NUMBER BREAKDOWN

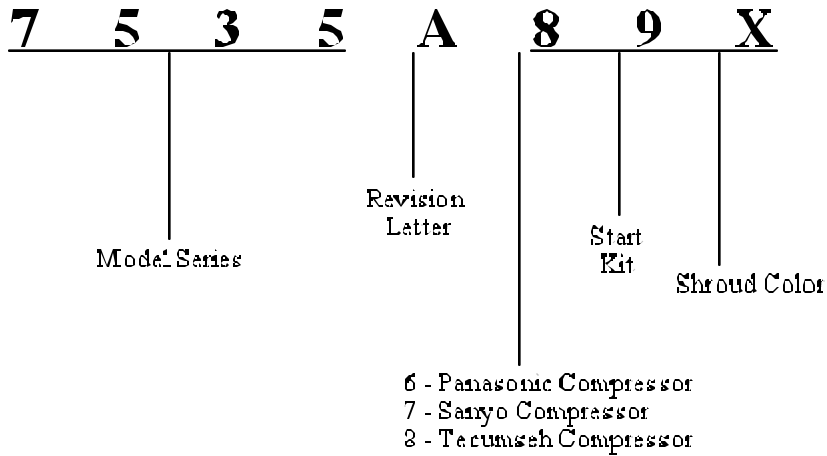

II. UNIT SPECIFICATIONS

Cooling Capacity Heating Capacity In Heat Pump Mode Heating Capacity Of Electric Heat Strip	15,000 (Nominal BTUH) 12,700 (Nominal BTUH at 47°F) 5,600 BTUH
Electrical Rating	115 VAC, 60 HZ, 1 Phase
Compressor Cooling Full Load Fan Motor Amps At A.R.I. Total Standard Condition	12.4 Low 2.8 High 3.3 15.2 15.7
Feature Heating Equipment Amps	15.4
Running Watts (Cooling) A.R.I. Standard Condition (80°F. DB/67°F. WB Indoor, 95°F. DB Outdoor at 103.5 VAC)	1710
Running Watts (Cooling) A.R.I. Maximum Condition (95°F. DB/71°F. WB Indoor, 115°F. DB Outdoor At 103.5 VAC)	2150
Running Watts (Heating) 47°F. Outdoor Temperature	1675
Compressor Locked Rotor Amps	71.0
Compressor Ohm Ratings (Approx.) C = Common, S = Start, R = Run	(C-S) 1.8 (C-R) .5
Thermostat Temperature Range	Cooling 55°F Heating 90°F
Metering Device	Capillary Tube
Refrigerant Charge	20.00 oz.
Evaporator Air Delivery	340 CFM - High
Installed Weight	110 lbs.
Use time delay fuse or circuit breaker (U.L. H.A.C.R. Type C.S.A.) rated at 20 amps. Supply wires 12 AWG minimum (copper).	

III. HEAT PUMP OPERATION WITH 7530-716 OR 8530-715 STANDARD CEILING ASSEMBLIES

If your RV air conditioner is operated from the control panel located in the ceiling assembly, then there are three controls on the ceiling assembly that help you control the air conditioner. They are as follows:

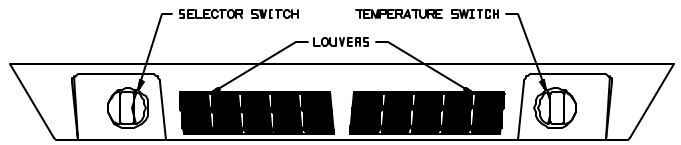
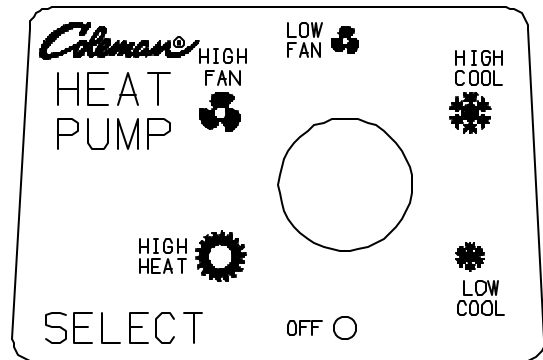

FIGURE 1

- A. The Selector Switch – The selector switch determines which mode of operation the heat pump will be in. By rotating the selector switch, the operator can obtain any system function desired. System functions vary depending upon options of both the roof top unit and ceiling assembly. Figures 1 and 2 show selector switch location and available functions.

The “Operation” section explains the operational characteristics of each mode of operation.

- B. The Thermostat (Temperature Control) – The thermostat regulates the “ON” and “OFF” temperature setting at which the compressor will operate (See Figures 1 and 2).
- C. Louvers – The louvers are located at both ends of the ceiling assembly shroud and are used in directing the discharge air from the unit.



CEILING ASSEMBLY STICKER

FIGURE 2

OPERATION

I. For Cooling Operation

- A. Turn the selector switch to the “LOW COOL” or “HIGH COOL” position.
- B. Rotate the thermostat (temperature control) to the position that is the most comfortable to you. The thermostat will turn the compressor on when the temperature of the air entering the air conditioner rises a few degrees above the setting you have selected. When the temperature of the air entering the air conditioner drops below the selected setting, the thermostat will turn the compressor off. The air conditioner, while in the cooling mode, will continue to cycle the compressor on and off in the above mentioned fashion until the selector switch is turned to another mode of operation.
- C. Position the louvers to the desired direction the discharge air is to flow.

II. Operation During Cooler Nights (Cooling Operation)

It is important, when the outdoor temperature drops in the evening or during the night to below 75°F, that the thermostat (temperature control) be set at a midpoint between “Warmer” and “Cooler”. If the setting is at “cooler”, the cooler (evaporator) coil may become iced-up and stop cooling. During the day, when the temperatures have risen above 75°F, reset the thermostat switch to the desired setting.

NOTE

Should icing-up occur, it is necessary to let the cooling (evaporator) coil defrost before normal cooling operation is resumed. During this time, operate the unit in the “HIGH FAN” position with the system at maximum air flow. When increased or full air flow is observed, the cooling coil should be clear of ice.

III. Short Cycling

When an air conditioner is in operation, its compressor circulates refrigerant under high pressure. Once off, it will take two to three minutes for this high pressure to equalize.

The air conditioning compressor is unable to start against high pressure. Therefore, once the air conditioner is turned off, it is important to leave it off for two to three minutes before restarting.

Short cycling the compressor (or starting it before pressures have equalized), will in some instances, kick the circuit breaker or overload.

IV. For Heating Operation

- A. Turn the selector switch to the “HIGH HEAT” position. At “HIGH HEAT”, the fan operates on high speed with heat output at maximum.
- B. Rotate the thermostat (temperature control) switch to the position that is the most comfortable to you. The thermostat will turn the compressor/heater on when the temperature of the air entering the unit drops below this setting a few degrees, and automatically turns off when the temperature of the air entering the unit rises a few degrees above this setting. The compressor/heater will continue to cycle on and off in this fashion until the selector switch is turned to another mode of operation.
- C. Position the louvers to the desired direction the discharge air is to flow.

Discharge air temperature can be controlled to some extent by opening or closing the louvers.

When the louvers are closed, the warmest localized discharge air is achieved. Fully opened louvers will throw the warm discharge air to the back and front of

the vehicle for more efficient circulation and faster warm-up. Although the air temperature is lower with the louvers fully opened, the heating capacity is still the same.

NOTE

The heat pump will operate on reverse refrigerant cycle while heating at outdoor temperatures above approximately 40 degrees F. When the outdoor temperature is below approximately 40 degrees F, the heat pump compressor will shut down to prevent outdoor coil freeze-up. At this time, the auxiliary electric resistance heater will be utilized to take the chill out of the indoor air. The electric resistance heater is not a substitute for a furnace at these low outdoor temperatures.

V. For Air Circulation Only

- A. Turn the selector switch to “LOW FAN” or for maximum air flow, to “HIGH FAN”.
- D. Position the louvers to the desired direction the discharge air is to flow.

NOTE

When the selector switch is in “LOW FAN” or “HIGH FAN” position, the blower motor will operate continuously.

IV. WALL THERMOSTAT SPECIFICATIONS AND HEAT PUMP OPERATIONS WITH 7530-736 or 8530-735 DUCTED PLENUMS

WALL THERMOSTAT SPECIFICATIONS

- SET TEMP. RANGE: 55° TO 90°F.
- ACCURACY: ± 2% OF SET TEMPERATURE
- SAMPLING RATE: CONTINUOUS
- POWER SOURCE: 9 TO 15 VDC UNREGULATED, UNFILTERED
- OPERATING TEMPERATURE: -10° TO +55°C.
- CONTROL MODE: 1 STAGE COOL - ON/OFF CONTROL WITH 3 MINUTE DELAY BETWEEN CYCLES
- OUTPUT LOAD: 40 mA MINIMUM TO 1.2 AMP MAXIMUM TOTAL LOAD
- SAFEGUARDS:
- * 15 KV E.S.D. TO EXPOSED PLASTIC PARTS
 - * REVERSE POLARITY PROTECTION ON R+ TERMINAL
 - * SPIKE PROTECTION TO 400 VDC ON R+ TERMINAL
 - * CONFORMAL COATING ON P.C. BOARD PROTECTION FROM MOISTURE

SUB-BASE SPECIFICATIONS

1. 7330*3351 THERMOSTAT MUST ASSEMBLE SECURELY TO THE SUB-BASE.
2. WIRES ARE 18 GA. STRANDED COPPER WITH 1/64 MIN. THICK AT INSULATION EXTENDING FROM BACK OF PART 7 INCHES, ENDS STRIPPED BACK 1/2" AND TERMINATED WITH WIRE NUTS.
3. SNAP DISC SWITCH CLOSSES AT 45 ±5°F AND OPENS AT 60 ±3°F.

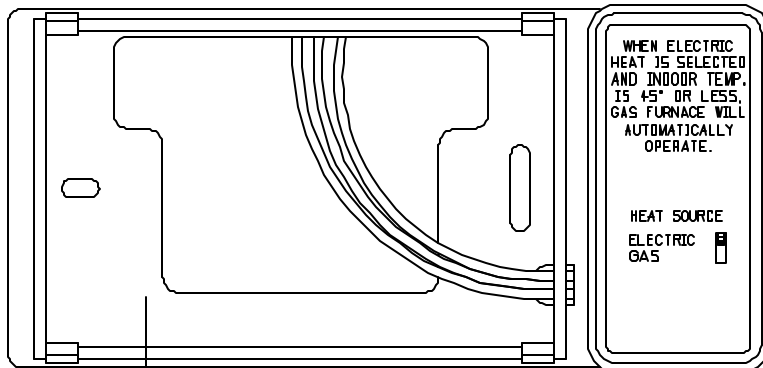

Sub-base

This thermostat is equipped with a replaceable 2 amp fuse located on the back of the thermostat body.

Thermostat Body

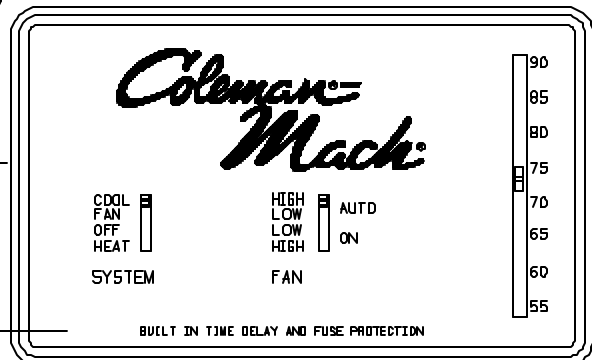

OPERATION

The charts below show the system functions. After the entire air conditioning system (and furnace system) is installed, check each position function.

HEAT SOURCE SWITCH		THERMOSTAT SUB-BASE OPERATION
ELECTRIC	GAS	
<input checked="" type="checkbox"/>	<input type="checkbox"/>	Heat pump operates, if called for, to provide heat. If outdoor temperature is near freezing, compressors may shut down on heat pump and the resistance heater will turn on. If room temperature drops below 45°, there will also be a call for furnace operation. The furnace will operate until heat demand is satisfied or until 60° is reached. The upper unit fan will operate at high speed only. Fan speed switch has no effect on system operation.
<input type="checkbox"/>	<input checked="" type="checkbox"/>	Gas furnace operates on demand - upper unit has no function.

<input checked="" type="checkbox"/> SHOWS POSITION OF SWITCH								OPERATION
SYSTEM		FAN		AUTO		ON		
HEAT	COOL	OFF	FAN	HI	LO	LO	HI	
<input type="checkbox"/>	<input type="checkbox"/>	<input checked="" type="checkbox"/>	<input type="checkbox"/>	<input type="checkbox"/>	<input type="checkbox"/>	<input type="checkbox"/>	<input type="checkbox"/>	No functions occur.
<input type="checkbox"/>	<input type="checkbox"/>	<input type="checkbox"/>	<input checked="" type="checkbox"/>	<input type="checkbox"/>	<input type="checkbox"/>	<input type="checkbox"/>	<input type="checkbox"/>	Air conditioner fan runs at high speed continuously regardless of fan switch setting or setpoint. No other functions occur.
<input type="checkbox"/>	<input checked="" type="checkbox"/>	<input type="checkbox"/>	<input type="checkbox"/>	<input checked="" type="checkbox"/>	<input type="checkbox"/>	<input type="checkbox"/>	<input type="checkbox"/>	Air conditioner: compressor, high speed fan and furnace high speed (if so equipped and wired), cycle to satisfy setpoint.
<input type="checkbox"/>	<input checked="" type="checkbox"/>	<input type="checkbox"/>	<input type="checkbox"/>	<input type="checkbox"/>	<input checked="" type="checkbox"/>	<input type="checkbox"/>	<input type="checkbox"/>	Air conditioner compressor, low speed fan and furnace low speed (if so equipped and wired), cycle to satisfy setpoint.
<input type="checkbox"/>	<input checked="" type="checkbox"/>	<input type="checkbox"/>	<input type="checkbox"/>	<input type="checkbox"/>	<input type="checkbox"/>	<input checked="" type="checkbox"/>	<input type="checkbox"/>	Air conditioner compressor cycles to satisfy setpoint. Air conditioner low speed fan and furnace low speed fan (if so equipped and wired) runs continuously.
<input type="checkbox"/>	<input checked="" type="checkbox"/>	<input type="checkbox"/>	<input type="checkbox"/>	<input type="checkbox"/>	<input type="checkbox"/>	<input type="checkbox"/>	<input checked="" type="checkbox"/>	Air conditioner compressor cycles to satisfy setpoint. Air conditioner high speed fan and furnace high speed fan (if so equipped and wired) run continuously.
<input checked="" type="checkbox"/>	<input type="checkbox"/>	<input type="checkbox"/>	<input type="checkbox"/>	<input checked="" type="checkbox"/>	<input type="checkbox"/>	<input type="checkbox"/>	<input type="checkbox"/>	Electric Heat Operation: (See thermostat sub-base operation chart for heat pump.) Gas Heat Operation: Furnace and furnace blower cycles to satisfy setpoint. Furnace blower operates from sequencer or time delay in furnace. Thermostat fan speed selection has no effect on the furnace blower. Air conditioning fan does not run.
<input checked="" type="checkbox"/>	<input type="checkbox"/>	<input type="checkbox"/>	<input type="checkbox"/>	<input type="checkbox"/>	<input checked="" type="checkbox"/>	<input type="checkbox"/>	<input type="checkbox"/>	Electric Heat Operation: (See thermostat sub-base operation chart for heat pump.) Gas Heat Operation: Furnace and furnace blower cycles to satisfy setpoint. Furnace blower operates from sequencer or time delay in furnace. Thermostat fan speed selection has no effect on the furnace blower. Air conditioning fan does not run.
<input checked="" type="checkbox"/>	<input type="checkbox"/>	<input type="checkbox"/>	<input type="checkbox"/>	<input type="checkbox"/>	<input type="checkbox"/>	<input type="checkbox"/>	<input checked="" type="checkbox"/>	Electric Heat Operation: (See thermostat sub-base operation chart for heat pump.) Gas Heat Operation: Furnace and furnace blower cycles to satisfy setpoint. Furnace blower operates from sequencer or time delay in furnace. Thermostat fan speed selection has no effect on the furnace blower. Air conditioning fan does not run.

All cooling functions controlling to setpoint have a short cycle protection time delay of 3 minutes.
There will be no delay if the cycle **OFF** time exceeds 3 minutes.

V. BASIC COMPONENTS AND THEIR FUNCTIONS
HEAT PUMP REFRIGERATION
SYSTEM DIAGRAM

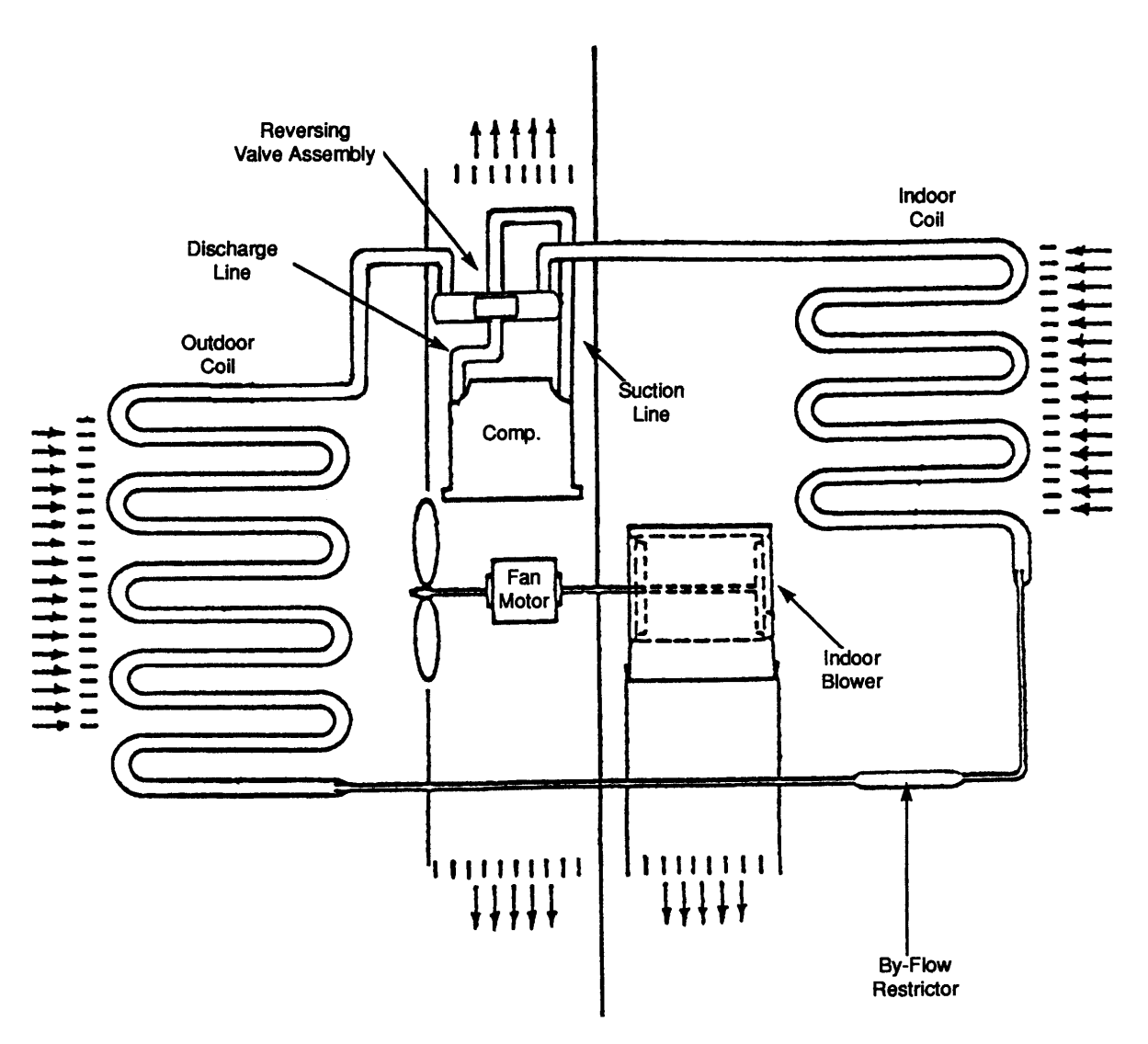

1. Indoor Coil (Cooling Mode)

The purpose of the finned evaporator coil is to transfer the heat from the warm and moist indoor air to the cold low pressure refrigerant.

As the heat leaves the air, the air temperature drops and some of the moisture in the air condenses from a vapor to a liquid. The liquid water (condensate) is drained onto the roof of the recreational vehicle. As the heat enters the refrigerant in the evaporator, it causes the refrigerant to evaporate (change from a liquid to a vapor).

The refrigerant remains at nearly constant temperature (called evaporator temperature or low side saturation temperature) in the evaporator since there are both liquid and vapor together. However, near the outlet of the evaporator coil, all of the liquid has boiled (evaporated) away and from there on, the temperature of the vapor rises (the vapor becomes superheated). It is necessary that the vapor become superheated because it is headed down the suction line to the compressor, and the compressor can only pump superheated vapor. Any vapor (which might be present if the vapor were not superheated) could cause serious mechanical damage to the compressor.

2. Suction Line

The suction line is the copper tube which carries the superheated vapor refrigerant from the evaporator to the compressor.

3. Compressor

The compressor is called a hermetic compressor which means it is completely sealed (welded together). It is, therefore, not internally field serviceable. Inside the compressor housing is basically:

- a) an electric motor which drives the compressor,
- b) a pump which is designed to pump superheated vapor,
- c) a supply of special refrigerant oil. A small portion of the oil will circulate out through the system with the refrigerant, but will constantly return to the compressor with the refrigerant, so the compressor will not run out of oil.

4. Outdoor Coil (Cooling Mode)

The purpose of the finned condenser coil is to transfer heat from the high pressure refrigerant to the warm outdoor air. As the outdoor air passes over the coil, the heat transfer will cause the air temperature to rise. Thus the condenser discharge air will be several degrees warmer than the

condenser entering air.

As the refrigerant passes through the first few tubes of the condenser, its temperature will be lowered or it will be de-superheated. After the refrigerant is de-superheated, it will begin to condense or change from a vapor to a liquid and will remain at a nearly constant temperature throughout almost all of the remainder of the coil. This temperature is called the condensing temperature or high side saturation temperature and will always be higher than the condenser entering air temperature.

Near the bottom of the condenser, the refrigerant will all be condensed to a liquid and from there on, its temperature will drop to more nearly the temperature of the outdoor air. After the temperature of the refrigerant drops below condensing or saturation temperature, we call its condition sub-cooled liquid.

During all of the three processes in the condenser (de-superheating, condensing, sub-cooling), the refrigerant gives up heat; but most of the heat is given up during the condensing process.

5. Reversing Valve

The reversing valve's main function is to reverse the flow of refrigerant. Internally, it is composed of two pistons on a sliding block or cylinder with two openings. The operation of the piston block is controlled by a solenoid valve. The solenoid valve controls the flow of the refrigerant, which produces a pressure difference in the valve itself. When the solenoid valve is energized, it is in the heating mode. When it is de-energized, it is in the cooling mode.

6. Discharge Line

The discharge line carries the refrigerant out of the compressor and to the reversing valve. The reversing valve then distributes this refrigerant to the outdoor coil during the cooling mode, and to the indoor coil in the heating mode. Remember that as the refrigerant entered the compressor, it was superheated vapor. As the compressor works on the refrigerant, it adds more heat and also compresses the refrigerant into a smaller space. The refrigerant, therefore, leaves the compressor highly superheated - so if the discharge line is hot to the touch (burns), don't be surprised - it should be.

7. By-Flow Restrictor

The by-flow restrictor is the metering device for the heat pump. The restrictor is made up of two orifices positioned back to back. There is a space between the orifices. As the system is either in the cooling or heating mode, it forces one of the orifices to seat at one of the tapered ends and force the other to break its seal. Refrigerant goes around one orifice and through the other, establishing the pressure drop. The orifices

are different sizes to accommodate for the difference in the condenser and evaporator sizes.

8. High and Low Sides

It is customary for air conditioning technicians to use the terms high side and low side. In doing so, we refer to the parts of the refrigerant circuit which, when the system is running, contains high pressure (high side) and low pressure (low side). The high side of the system exists from the discharge port of the compressor to the metering device. The low side is from the metering device to the compressor cylinders. The dividing points then are the metering device and the compressor cylinders.

The high side pressure is also referred to as heat pressure or condensing pressure, and the low side pressure is also referred to as suction pressure or evaporator pressure.

It is impossible to state the exact pressures that will exist in the high side or low side because those pressures will both vary with different temperature and humidity conditions both inside and outside the recreational vehicle.

9. Refrigerant Charge

The system covered by this service manual all use a refrigerant called monochlorodifluoromethane (better known as R-22).

We know that R-22 is not a deadly gas because many of us have breathed it several times and are still living. But, no one has said that R-22 is completely safe to breathe. A wise service technician will always keep a work space well ventilated if R-22 can escape into the air. IF R-22 IS

RAISED TO A HIGH TEMPERATURE IN THE PRESENCE OF WATER (WHICH ALWAYS EXISTS IN THE ATMOSPHERE), IT DEFINITELY DOES BECOME A TOXIC GAS by changing from virtually harmless R-22 to phosgene and hydrofluoric acids. So, if R-22 in the air is exposed to a welding or soldering torch flame, burning water heater burner, burning furnace burner, etc., be sure to avoid breathing it.

The temperature at which R-22 changes to toxic gases and acids varies with the amount or concentration of water present, i.e. the greater the concentration of water, the lower the temperature and vice versa. High temperatures normally exist inside a refrigerant circuit, so we must keep the circuit as absolutely dry as possible to prevent the formation of destructive acids.

Liquid R-22 in the atmosphere will always be about -41 degrees. Therefore, always wear safety glasses when working with R-22.

Again, unburned R-22 is not a deadly gas. By using reasonable safety precautions, the service technician will not be hurt.

In addition to being almost non-toxic, R-22 is non-flammable, non-corrosive and miscible (mixable) with oil. It also has a high latent heat value. This means that it must absorb a large amount of heat per pound to vaporize or change from a liquid to a vapor, and it must give up a large amount of heat per pound to condense or change from a vapor to a liquid.

VI. THE HEAT PUMP REFRIGERATION CYCLE

The Heat Pump is a refrigeration system like any other refrigeration system, that heat transfers from one place to another by the change in state of a liquid. The Heat Pump can reverse the action or direction of heat transfers. For summer cooling, it can remove heat from occupied areas and dispose of the heat into outside air. For any time heat is needed, it reverses the action with a reversing valve and will

also remove heat from the outside air source and supply heat to the occupied area. We re-label the coils as indoor and outdoor as they are now dual purpose, depending on the usage desired. The outdoor coil is the condenser in the cooling cycle and the evaporator in the heating cycle. The indoor coil is the evaporator coil in the cooling cycle and the condenser coil in the heating cycle.

VII. GENERAL ELECTRICAL OPERATIONAL INFORMATION

HEAT PUMP ELECTRICAL OPERATION 7530-716 or 8530-715 STANDARD CEILING ASSEMBLIES

All air conditioning functions operate the same as a standard air conditioner. While in the heating mode with the selector switch in the High Heat position, the #3 terminal will energize the reversing valve and the compressor. At the same time, the #1 terminal will energize high speed on the fan motor. The refrigeration cooling cycle is now reversed and the air conditioner is now heating running on high speed fan.

The freeze switch or outdoor thermostat located on the condenser coil opens at $18^{\circ} (\pm 6^{\circ})$ actual coil temperature, not ambient temperature. When this switch opens, the compressor shuts off. The reversing valve remains in the heating position and the fan continues to run on high speed. When the compressor shuts off, the freeze switch will also energize a 5600 BTU electric heating element.

This heating element will continue to run until the freeze switch resets allowing the operation of the heat pump. At no time will you have the heat pump and the electric heat strip on at the same time.

NOTE

The heat pump should be considered a cooling unit which also provides heat at outdoor temperatures above freezing. This unit will shut down at low ambient conditions that would cause outdoor coil freeze-up, approximately 40 degrees.

HEAT PUMP ELECTRICAL OPERATION WITH 7530-736 OR 8530-735 DUCTED CEILING ASSEMBLIES

All air conditioning functions operate the same as a standard air conditioner. While in the heating mode with the wall thermostat in the electric heating position, the white wire (or the "W" terminal) will energize the reversing valve relay in the ceiling assembly. At the same time, it will energize both the compressor relay terminal "Y" and high speed fan relay terminal "GH" through blocking diodes on the terminal board. Hence, the refrigeration cooling cycle is now reversed and the air conditioner is now heating and running on high speed fan.

The blocking diode located on the terminal board just ahead of the "Y" terminal prevents 12 VDC (+) feedback to the cooling fan circuit while in the heating mode. Without this, someone could put the fan switch on the thermostat in the low position, and energize both high and low speed fan operations at the same time.

The freeze switch or outdoor thermostat located on the condenser coil opens at $18^{\circ} (\pm 6^{\circ})$ actual coil temperature, not ambient temperature. When this switch opens the compressor shuts off. The reversing valve remains in the heating position

and the fan continues to run on high speed as long as the wall thermostat is still calling for electric heat. When the compressor shuts off, the freeze switch will also energize a 5600 BTU electric heating element.

This heating element will continue to run until the wall thermostat is satisfied or until the freeze switch resets allowing the operation of the heat pump. At no time will you have the heat pump and the electric heat strip on at the same time. Should conditions exist where neither the heat pump nor the electric heating element are able to meet the demand for heat, the thermostat will default to gas heat at an indoor ambient temperature of 45° .

NOTE

The electric heat strip or heat pump will also continue to operate congruently during this period. The gas heat default will terminate at $60^{\circ} (\pm 3^{\circ})$.

7330-3401 THERMOSTAT SUB-BASE OPERATION

The RVP wall thermostat sub-base part #7330-3401 will give the customer the option to choose between electric or gas furnace operation. This sub-base may be used with all heat pump ceiling plenums.

Neither the electric heating strip or the heat pump were intended to replace the gas furnace, and at some point, the capacity of either one of these will not be sufficient to keep up with the heating load required. It will ultimately be up to the

retail customer to choose between electric or gas heating to achieve his or her desired comfort level.

NOTE

The electric heat strip or heat pump will also continue to operate congruently during this period. The gas heat default will terminate at 60° (± 3°).

The thermostat sub-base combination will operate normally in either the electric or gas heating positions and will cycle on and off at the setpoints. Should the electric heat strip or heat pump not be able to keep up with the demand for heating, the sub-base has a built-in snap disc switch which will automatically default to gas heat when the temperature inside drops below 45°F (± 5°), even if the electric heat position is chosen. This happens for safety purposes to prevent the vehicle from becoming too cool or possibly freezing when the customer is not home to monitor his heating system.

VIII. SERVICE PROBLEMS AND POSSIBLE SOLUTIONS

SERVICE PROBLEMS WITH THE HEAT PUMP AND THE 7530-736 OR 8530-735 DUCTED CEILING ASSEMBLY AND WALL THERMOSTAT

The following list of service problems covers only some of the more common problems which may occur and lists only the more probable causes.

In many instances, it will be necessary to use the wiring diagram in this guide to checkout the electrical circuits step by step, starting at the power source.

PROBLEMS	POSSIBLE CAUSES (REFER TO THE INDIVIDUAL COMPONENT CHECKOUT PROCEDURES)
Nothing Runs, No Compressor, No Fan, No Heat	No A/C Voltage, No 12 VDC, Thermostat, Wiring, Printed Circuit Board
Fan Runs, No Compressor Operation In The Cooling Mode	Insufficient Voltage To The Unit, Wiring, Thermostat, Printed Circuit Board, Start Capacitor, Run Capacitor, Start Relay, Open Overload, Thermistor, Open Outdoor Thermostat, Compressor
Fan Runs, No Compressor Operation In The Heat Pump Mode	Insufficient Voltage To The Unit, Wiring, Thermostat, Thermostat Sub-base, Printed Circuit Board, Start Capacitor, Run Capacitor, Start Relay, Open Overload, Thermistor, Compressor
Heat Or Compressor Runs, No Fan Operation	Wiring, Thermostat, Printed Circuit Board, Fan Capacitor, Fan Motor
Fan Runs, No Electric Heat Element, Heat Pump Runs	Wiring, Thermostat, Thermostat Sub-base, Printed Circuit Board, Limit Switch, Open Outdoor Thermostat, Heating Element
Fan Runs, Compressor Runs, No Heat If Unit Is Cooling In The Heat Pump Mode	Wiring, Printed Circuit Board, Reversing Valve Solenoid
Compressor Runs, Fan Runs, Insufficient Heat In Heat Pump Mode	Air Flow Restrictions, Outdoor Thermostat May Open Due To Low Ambient Temperature, (Undersized) Too Much Heat Loss To The Vehicle, Refrigeration System, Very Little Or No Refrigerant Charge, Compressor
Compressor Runs, Fan Runs, Insufficient Cooling	Air Flow Restrictions, High Ambient Temperature, (Undersized) Too Much Heat Gain To The Vehicle, Refrigerant System, Very Little Or No Refrigerant Charge, Compressor. (IF YOU HAVE NOT BEEN PROPERLY TRAINED IN REFRIGERATION SEALED SYSTEM REPAIRS, DO NOT ATTEMPT TO BREAK INTO THE SYSTEM.)

SERVICE PROBLEMS WITH THE HEAT PUMP AND THE 7530-716 OR 8530-715 STANDARD CEILING ASSEMBLIES

The following list of service problems covers only some of the more common problems which may occur and lists only the more probable causes.

In many instances, it will be necessary to use the wiring diagram in this guide to check out the electrical circuits step by step, starting at the power source.

PROBLEMS	POSSIBLE CAUSES (REFER TO THE INDIVIDUAL COMPONENT CHECKOUT PROCEDURES)
Nothing Runs, No Compressor, No Fan, No Heat	No A/C Voltage, Selector Switch
Fan Runs, No Compressor Operation In The Cooling Mode	Insufficient Voltage To The Unit, Wiring, Thermostat, Start Capacitor, Run Capacitor, Start Relay, Open Overload, Selector Switch, Compressor
Fan Runs, No Compressor Operation In The Heat Pump Mode	Insufficient Voltage To The Unit, Wiring, Thermostat, Selector Switch, Start Capacitor, Run Capacitor, Start Relay, Open Overload, Outdoor Thermostat Opened, Compressor
Heat Or Compressor Runs, No Fan Operation	Wiring, Selector Switch, Fan Capacitor, Fan Motor
Fan Runs, No Electric Heat Element, Heat Pump Runs	Wiring, Thermostat, Selector Switch, Limit Switch, Outdoor Thermostat, Heating Element
Fan Runs, Compressor Runs, No Heat If Unit Is Cooling In The Heat Pump Mode	Wiring, Selector Switch, Reversing Valve Solenoid
Compressor Runs, Fan Runs, Insufficient Heat	Air Flow Restrictions, Outdoor Thermostat May Open Due To Low Ambient Temperature, (Undersized) Too Much Heat Loss, In The Vehicle, Refrigeration System, Very Little Or No Refrigerant Charge, Compressor
Compressor Runs, Fan Runs, Insufficient Cooling	Air Flow Restrictions, High Ambient Temperature, (Undersized) Too Much Heat Gain To The Vehicle, Refrigerant System, Very Little Or No Refrigerant Charge, Compressor (IF YOU HAVE NOT BEEN PROPERLY TRAINED IN REFRIGERATION SEALED SYSTEM REPAIRS, DO NOT ATTEMPT TO BREAK INTO THE SYSTEM.)

IX. INDIVIDUAL ELECTRICAL COMPONENT CHECKOUTS

THINK SAFETY

1. Power Supply - From Commercial Utility

1) Wire Size

The power supply to the air conditioner must come through a circuit breaker or time delay fuse. The power supply must be 20 amperes and 12 AWG wire minimum. Any size larger wire at any time may be used and **should** be used if the length of the wire is over 32 feet.

2) Color Code

The electric power from the electric service panel should be delivered through a 3 conductor cable and the Service Technician should check to be sure the color code is correct. The electrician probably installed the cable with the colors according to code, but don't bet your life on it.

- a) The wire with black insulation is the hot wire and there should be 115 volts (domestic USA) between it and either of the other wires. All switches, fuses, circuit breakers, disconnects, etc. should be in this line.

b) The wire with the white insulation is the neutral. There should be 115 volts (domestic USA) between the neutral and the hot (black) wire, but there should be 0 volts between the neutral and the ground (the green wire or the frame of the air conditioner). **There must be no switches, fuses, disconnects, etc.** of any kind in the neutral wire.

c) The third wire may be covered with green insulation or it may be a bare metal wire. It is the ground wire. There must be 115 volts (domestic USA) between this wire and the hot (black) wire and 0 volts between it and the neutral (white) wire. The ground wire must be securely fastened to the air conditioner cabinet. A green headed screw is provided for this purpose.

3) Voltage

The voltage (electrical pressure) at the unit should be 115 volts (domestic USA) and all electrical components will perform best at the correct voltage. However, the voltage will vary and the air conditioning system will perform satisfactorily within plus or minus 10% of the rated (115) voltage (domestic USA). Therefore, the voltage has to be between 103.5 volts and 126.5 volts.

2. Power Supply - Generated By On-Board Motor Generator

If the power supply for the recreational vehicle is supplied by an on-board motor generator, its wiring may be identical to the commercial power described above.

There are, however, some motor generators on which both the current carrying leads are insulated from the ground. That is to say, there is no grounded neutral, so there will be 115 volts (domestic USA) between the black and white leads, but there will be 0 volts between either lead and ground.

WARNING: The service technician must keep in mind when checking to make sure that the power is turned off. Check only between the hot (black) lead and the neutral (white) lead. The black lead could still be hot even though there is 0 volts between it and ground.

3. Compressor Motor

The compressor motor is located inside the hermetic compressor housing and is therefore, not accessible for service or visual observation in the field. However, the motor winding condition can be analyzed by using an ohm meter. Be sure to remove all the leads from the compressor terminals before making this check.

a) If the resistance between any two terminals is 0 ohms, the motor windings are shorted.

b) If the resistance between any terminal and the compressor housing is anything but infinity, the winding is grounded.

4. Overload Switch

Mounted internally within the compressor housing is an overload switch. The switch is connected in series with the common terminal; so if the switch opens, it will cut the power to the compressor motor. The switch will open as the result of either or both of two conditions that could be harmful to the compressor.

a) High Amperes (Current)

The switch contains a heater which increases in temperature as the current increases. The higher temperature warps the switch and will cause it to open before the windings reach a dangerous temperature.

b) High Temperature (Thermal)

The switch is clamped tightly against the compressor housing and located close to the windings. Therefore, as the windings reach a higher temperature, it takes less current to cause the switch to open.

As can be seen, the switch is always affected by a combination of current to the compressor and winding temperature.

5. Fan Motor

The air conditioning unit has **one** double end shaft fan motor. On one shaft end is mounted a centrifugal or squirrel cage blower which draws air (return air) out of the recreational vehicle and blows the conditioned air down into the recreational vehicle. On the other shaft end is mounted an axial flow or propeller type fan which circulates outdoor air through the condenser coil.

An important step in installing a replacement fan motor is to check the direction of rotation before it is installed. On all models, the condenser fan pulls the air through the coil.

Fan Motor Check Procedure

If a fan motor refuses to perform properly, it can be checked in the following manner:

1. Be sure the motor leads are connected to the proper points –
 - a) The black wire from the motor connects to a black wire inside a wire nut then the black wire connects through the disconnect plug to the selector switch. The red wire from the motor connects to a red wire in a wire nut, then the red wire connects through the disconnect plug to the selector switch.
 - b) The white wire from the motor connects to a white wire in a wire nut then the white wire connects through the disconnect plug to the thermostat.
 - c) The brown wires from the motor connect to the fan capacitor.
2. To check the motor winding resistance carefully, check the resistance between each of the wires and ground (preferably a copper refrigerant tube for a good connection). These readings must be infinity. Any continuity means the windings are grounded.

If there is a reading of 0 between any two leads, the motor is shorted and is no good. If there is a reading of infinity between any two leads, the winding is open and the motor is no good.

6. Selector Switch - Free Delivery Ceiling Assemblies

The selector switch is mounted on the left side of the interior ceiling assembly. Check for continuity between the terminals with an ohm meter.

<u>Switch Position</u>	<u>Continuity</u>
HEAT	L - 1 - 3
LO FAN	L - 1
HI FAN	L - 2
LO COOL	L - 1 - 4
HI COOL	L - 2 - 4

7. Thermostat (Mechanical Rotary)

The thermostat (temperature controller) is mounted on the right side of the interior ceiling assembly. The thermostat controls the on-off cycle of the compressor when the selector switch is in the cooling position and the on-off cycle of the heat pump or electric heater when the selector switch is in the

heating position. The thermostat is actuated by sensing the temperature of the return air through the vent where the bulb is located. Check continuity between terminals with an ohm meter.

8. Heating Element

The heating element is a resistance heater of 1600 watts (5600 BTUH) capacity and is connected across the line when the selector is set for heating and the thermostat is calling for heat. The current draw of the heater (element only) will be 13.9 amperes at 120 volts (domestic USA models).

9. Limit Switch (Heating Element)

The limit switch is a safety switch and is mounted in the heating element frame. It will open and break the circuit on temperature rise in case the air flow through the heater becomes low enough to cause the heater to overheat. Limit switch may be checked for continuity with an ohm meter.

10. Run Capacitors

The purpose of the run capacitors is to give the motors starting torque and to maintain high power factor during running. The run capacitors are always connected between the start and run or main terminals of the motor.

One of the terminals of the run capacitors will have a red dot (the identified terminal). The identified terminal should always be connected to the run or main terminal of the motor and to the neutral line.

Capacitor Check

There are several capacitor test devices available. The ohm meter is one of them. The ohm meter cannot verify a capacitor's MFD (microfarad) value. However, the following procedures will show you how to use an ohm meter to determine if the capacitor is good, open, shorted or grounded.

Before testing any capacitor, always perform the following procedure:

- a) Disconnect all electrical power to the air conditioner.
- b) Discharge the capacitor with a 20,000 ohm (approx. 3 watt) resistor or larger.
- c) You may discharge capacitors with a standard volt meter if you use a scale over 500 volts and touch the leads (one lead to each side of the capacitor), the volt meter will discharge the capacitor.
- d) Identify and disconnect the wiring from the capacitor.

e) Set and zero the ohm meter on the "highest" scale.

When testing for a good, open or shorted capacitor, perform the following checks: Place the ohm meter leads across the capacitor terminals (one lead on each terminal) and perform a continuity test. Then observe the action of the meter needle or indicator. Reverse the leads and test again. The result should be the same. Note: If the capacitor had not been properly discharged, a false reading could be indicated on the first test. Always test several times (reversing the leads with each test). This will verify the capacitors condition.

Good Capacitor

If the capacitor is good, the indicator will move from infinity (the left side), up towards zero ohms and slowly return back to infinity. Reverse the leads and test again. The result should be the same.

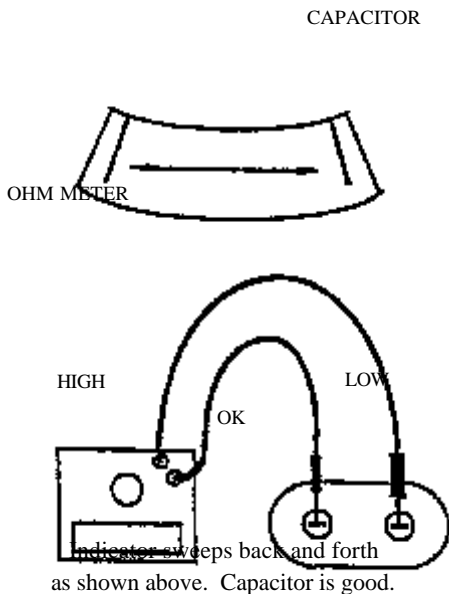

Open Capacitor

If the capacitor is open, the indicator will show no deflection or movement. Reverse the leads and test again. If there is no indicator movement on the second test, the capacitor is open. Open capacitors are defective and must be replaced.

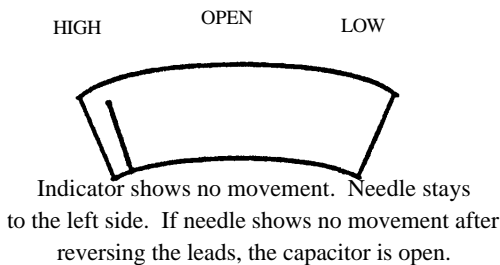

Shorted Capacitor

If the capacitor is shorted, the indicator will move toward and sometimes hit zero ohms, and will stay there. This indicates a completed circuit through the inside of the capacitor (shorted). Shorted capacitors are defective and must be replaced.

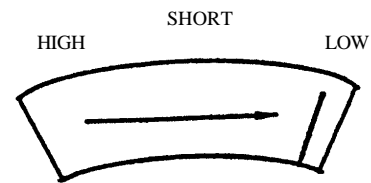

Indicator moves to the right side of the scale and stays there (indicating a completed circuit). The capacitor is shorted.

Grounded Capacitor

When testing for a grounded capacitor, perform a continuity check between each terminal on the capacitor and the bare metal of the capacitors case. Any indication of a circuit (constant resistance) from either terminal to case, indicates a grounded capacitor. Grounded capacitors are defective and must be replaced.

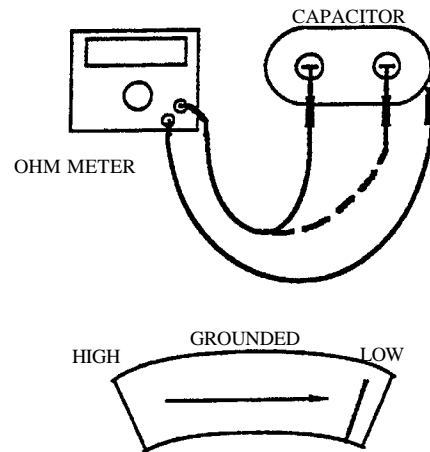

Indicator moves to the right side of the scale and stays there (indicating a completed circuit). The capacitor is grounded.

11. Start Capacitor

Most models use a start capacitor and a start relay to give the compressor high starting torque. The compressor will, therefore, start against normal pressure difference (head pressure minus suction pressure) even when shut down for a short period of time. The start relay will disconnect the start capacitor when the motor reaches approximately 75% running speed.

12. Start (Potential) Relay

The start relay consists of –

- Normally closed contacts internally between terminals #1 and #2 which switch in the start capacitor in parallel to the run capacitor during shut down and then switch out the start capacitor when the motor reaches approximately 75% normal running speed.
- A high voltage coil internally between terminals #5 and #2 to actuate the contacts. The coil is too weak on line voltage to actuate the contacts, but it is connected in series with the start winding and it gets the generated voltage of the start winding portion of the compressor motor. This generated voltage is much higher than line voltage and varies with the

speed of the motor. Therefore, since the relay is designed to open the contacts at 75% of normal running voltage (measured between terminals #5 and #2), the contacts will open (thus disconnect the start capacitor) at approximately 75% of normal running speed.

13. Thermistor

The thermistor is a freeze protection device installed in the compressor relay circuit to prevent evaporator coil freeze-ups. This device is a semi-conductor which has electrical resistance that varies with temperature. The thermistor cutout temperature is 31°F (± 3°) and reset temperature is 53°F (± 3°).

14. Outdoor Thermostat (Freeze Switch)

The outdoor thermostat is a normally closed switch wired in series with the compressor common wire.

The outdoor thermostat is located on the condenser coil opens at 18° (± 6°) actual coil temperature, not ambient temperature. When this switch opens, the compressor shuts off.

Thermostat Terminal	Mate With	Control And Supply Wiring	Ceiling Assembly Terminal
R or Red		One Red, +12 VDC Supply Wire To Thermostat	N/A
B or Blue		Two Blue, One -12 VDC Supply Wire To Thermostat And One Blue Control Wire To Ceiling Assembly/Plenum	B
Y or Yellow		One Yellow, Compressor Control Wire To Ceiling Assembly/Plenum	Y
GH or Green		One Green, Hi Fan Control Wire To Ceiling Assembly/Plenum	GH
GL or Gray		One Gray, Lo Fan Control Wire To Ceiling Assembly/Plenum	GL
N/A or Cool Only Models		W or White	Thermostat Sub-base (Electric or Gas Heat)
700L Series Thermostat Only		HH or Purple	Furnace Blower High
		HL or Brown	Furnace Blower Low
Thermostat Operations		Internal 12 VDC Connections Made	
Low Cooling		Red To Yellow And Gray	
High Cooling		Red To Yellow And Green	
High Heat		Red To White	
Fan Only (Hi Fan)		Red To Green	

15. 7330-3351 Wall Thermostat

The thermostat is a temperature control switch that maintains a temperature within an occupied space. When different thermostat operations are chosen, the following internal electrical connections are made (see chart below). The electrical signals from the thermostat to the heat pump controls will ultimately close relays on the printed circuit board to energize the different functions.

16. 7330-3401 Thermostat Sub-base

The thermostat sub-base is also a switch except its purpose is to make a selection between electric and gas heat. The chart below shows the connections to its outputs.

Operation	Internal 12 VDC Connections Made	
Electric Heat	White To White/Black	Electric Heat Element In Ceiling Assembly/Plenum
Gas Heat	White To Orange	Furnace

17. Printed Circuit Boards (Low Voltage Controls) Ducted Ceiling Plenums

The printed circuit boards and low voltage control circuits for inducted ceiling plenum applications simply replace the selector switch and rotary thermostat controls on the manually controlled units. The printed circuit boards purpose is to receive the various (12 VDC) low voltage control signals from the wall thermostat, and then use these signals to close the relay contacts located on the printed circuit board. Once the relay has closed, the high voltage power goes through the heat pump conduit assembly to operate the compressor, reversing valve coil or the fan motor.

Troubleshooting Tips

1) To troubleshoot this printed circuit board, it will first be necessary to verify the presence of low voltage (12 VDC) to the low voltage terminal board connections (see the chart below). For wiring schematic, see diagram on page 21.

- B -12 VDC for all relay coils
- Y +12 VDC for compressor relay coil
- GH +12 VDC for hi fan relay coil
- GL +12 VDC for low fan relay coil
- W +12 VDC for heat relay coil
- F > Coil sensor opens circuit to compressor relay. In case of coil freeze-up, the switch opens 30° and closes 55°. It is permissible to jumper these two terminals for test purposes only.
- F >

Example:

For high speed fan operation, a 12 VDC potential between the terminals GH (+) and B (-) are necessary. For compressor operation, a 12 VDC potential between Y (+) and B (-) is necessary. If this is not present, see the wall thermostat checkout procedure. The problem is evidently not in the printed circuit board.

2) After the low voltage control circuits have been verified, we may now check to see if the relays on the printed circuit board are operating. The first step is to insure there is a 115 VAC power supply to the printed circuit board high voltage terminals. Secondly, locate the 9 pin high voltage connector plug located on top of the wiring box (see the wiring diagram on page 23 of this manual). This is an excellent place for measuring high voltage output from the printed circuit board to the upper unit components. It will be necessary to unplug the upper unit to perform these tests. The chart below indicates which pin terminals will have a 115 VAC potential between them if the relays do successfully close.

12 VDC POTENTIAL TO LOW VOLTAGE BOARD		115 VAC POTENTIAL AT HIGH VOLTAGE CONNECTOR PLUG	ENERGIZES
(+)	(-)		
GH	B	Pin #5 Black Wire and Pin #9 White Wire	High Fan
GL	B	Pin #6 Red Wire and Pin #9 White Wire	Low Fan
Y	B	Pin #3 Purple Wire and Pin #1 White Wire*	Compressor
W	B	Pin #3 Purple Wire and Pin #1 White Wire Pin #5 Black Wire and Pin #9 White Wire Pin #2 Blue Wire and Pin #1 White Wire	Compressor High Fan Reversing Valve Coil

* Caution: Before determining the p.c. board is bad, make sure you warm the thermostat to a temperature above 55°F or temporarily jump across the terminals "F" and "F" on low voltage board to insure the compressor relay closes.

X. WIRING DIAGRAM 7535 AND 8535 SERIES HEAT PUMP

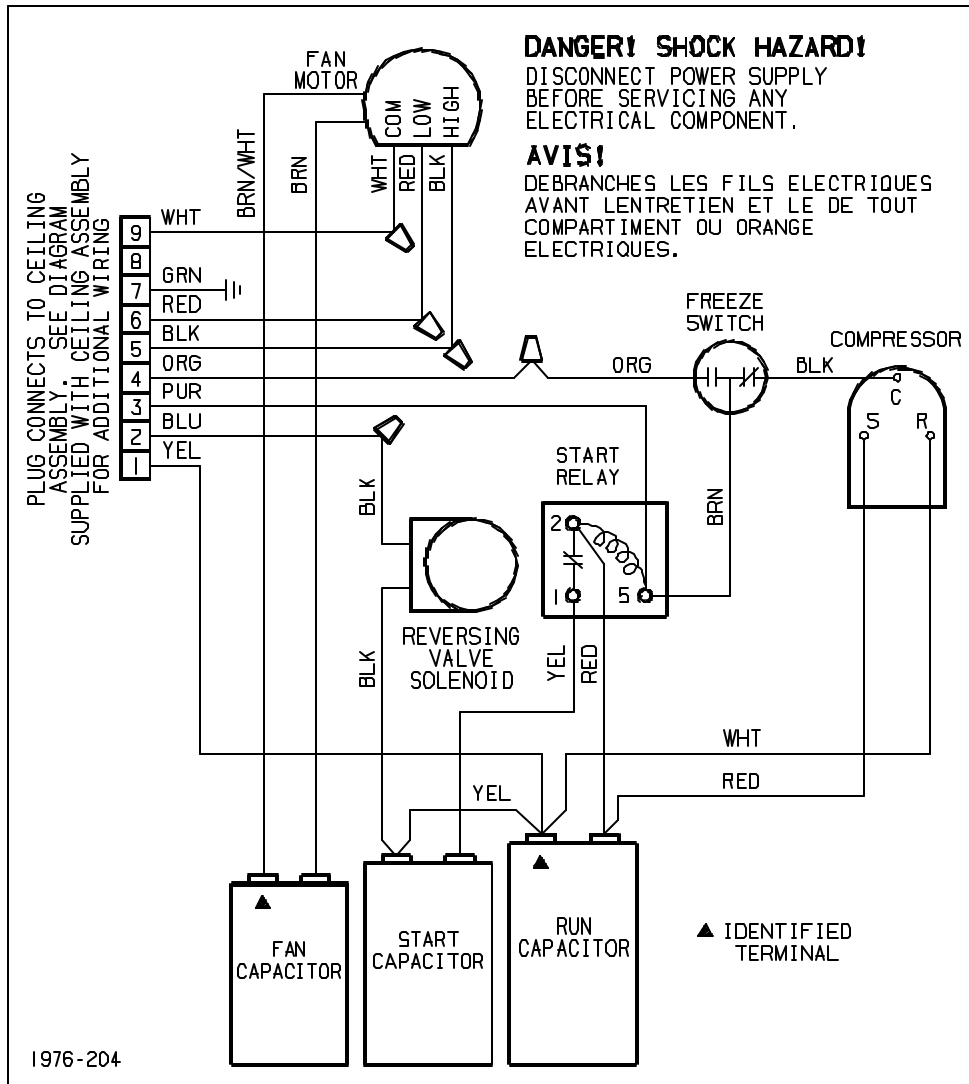

WIRING DIAGRAM 8534 SERIES HEAT PUMP

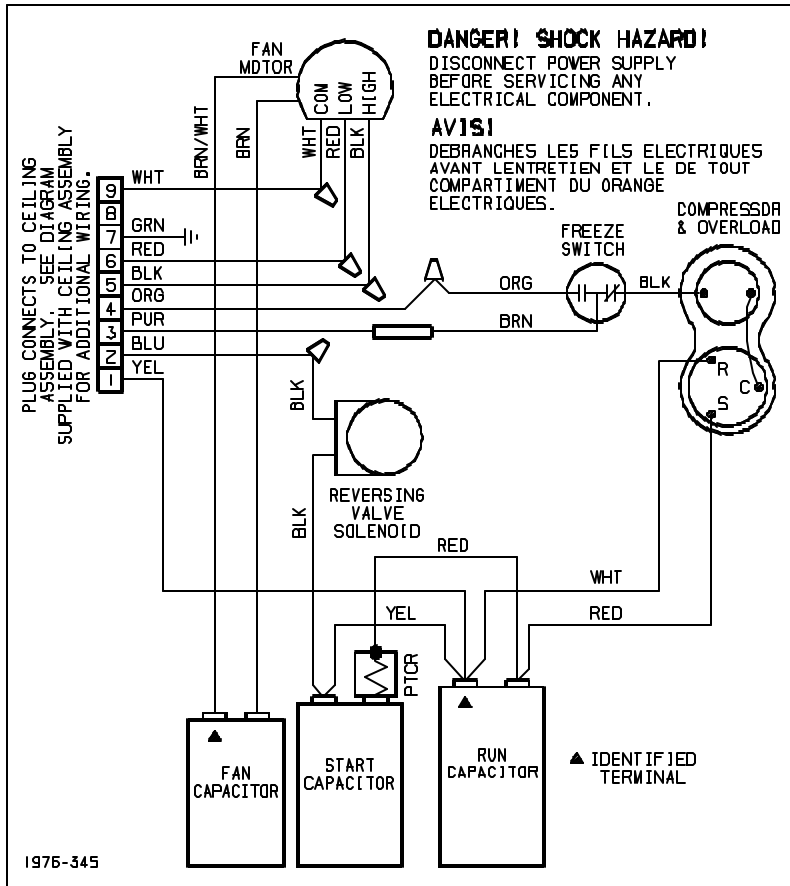

WIRING DIAGRAM FOR THE 7530-716 AND 8530-715 HEAT PUMP FREE DELIVERY CEILING ASSEMBLIES

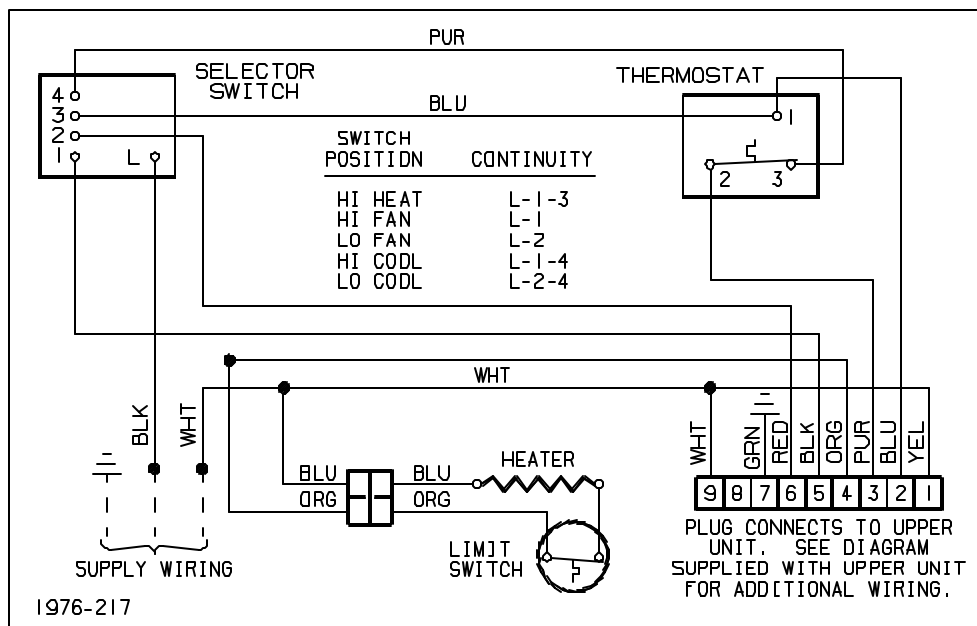

**WIRING DIAGRAM FOR THE
7530-736 AND 8530-735 DUCTED
CEILING ASSEMBLIES**

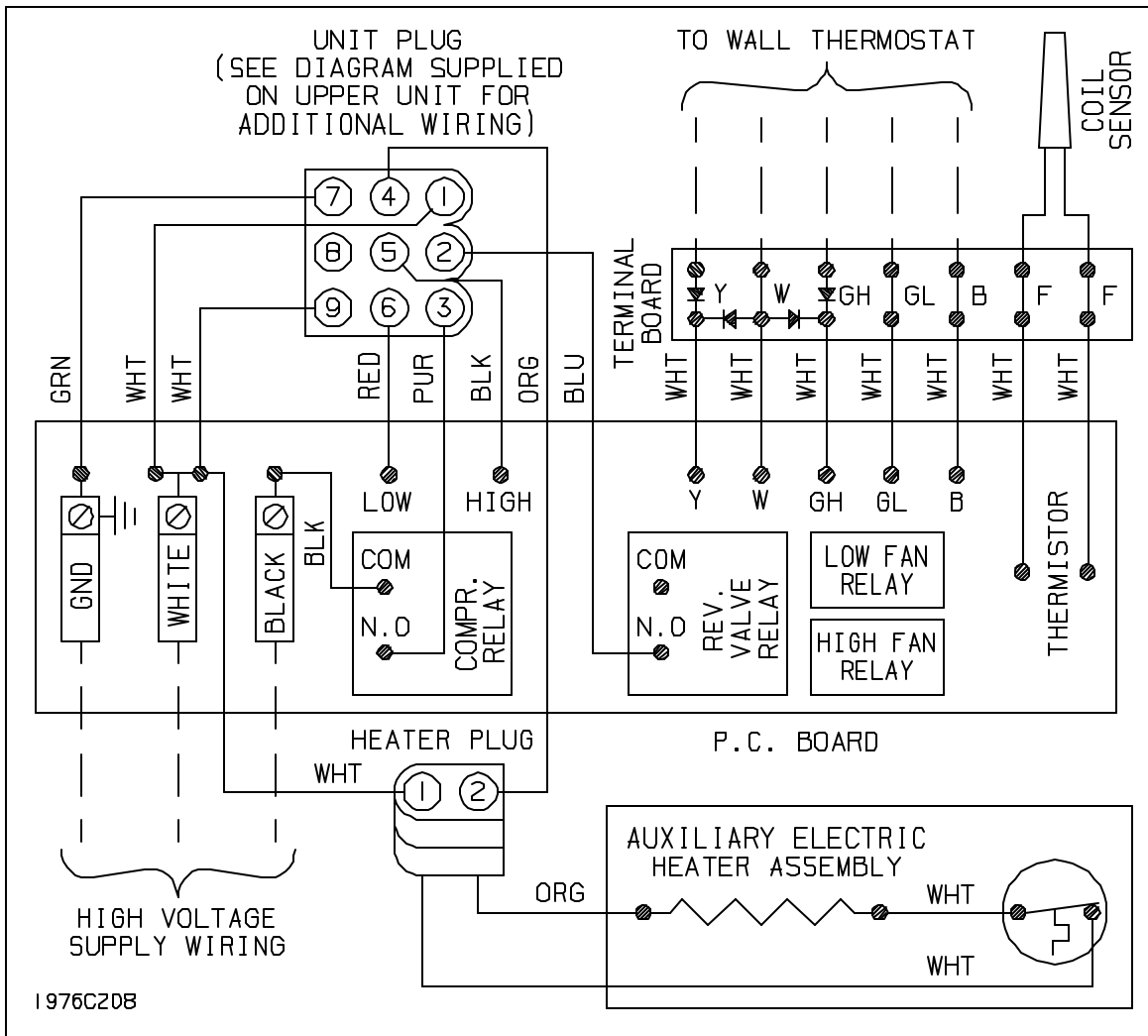

**WIRING DIAGRAM FOR THE
7330*3351 WALL THERMOSTAT**

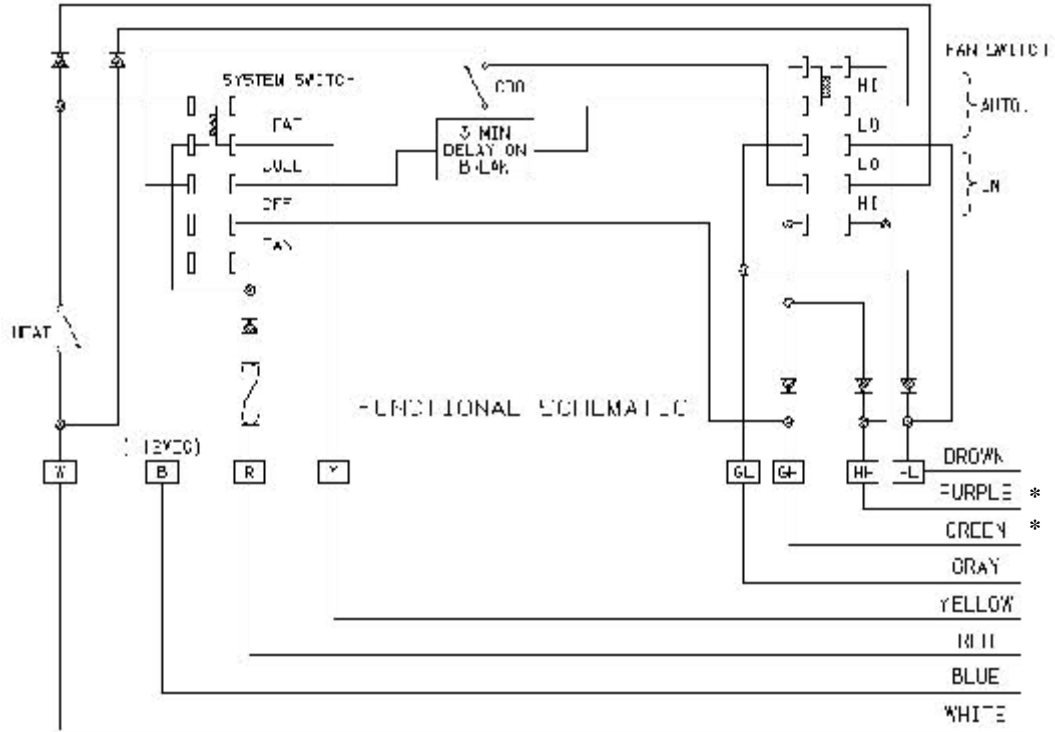

*** Brown and Purple Thermostat Wires May Have Been Eliminated On The Newer Model Wall Thermostats.**

**WIRING DIAGRAM FOR THE
7330-3401 SUB-BASE**

