

**Roof A/c**



**SERVICE MANUAL**

**FOR**

**6700, 7000, 8000 & 9000 SERIES**

**AIR CONDITIONERS**

**(MECHANICAL CONTROLS ONLY)**

**FOR WALL MOUNT THERMOSTATS AND LOW VOLTAGE CONTROL  
CIRCUITS, REFER TO THEIR APPROPRIATE MANUALS**

**FOR ELECTRICAL CHECKOUTS ON DELTA T AND DELTA TX  
AIR CONDITIONERS, REFER TO MANUAL R-332 (2-86)**

## PREFACE

This service manual is primarily intended for the use of qualified individuals specially trained and experienced in the service of this type of equipment and related system components.

Installation and service personnel are required by some states, counties or cities to be licensed. Persons not qualified shall not attempt to service this equipment or interpret this service manual.

## SCOPE

This is not a basic refrigeration and air conditioning manual and does not therefore, cover the principles of refrigeration or air conditioning. The user of this manual should have already accomplished a thorough study of refrigeration and air conditioning.

## WARNING

Improper installation may damage equipment, can create a hazard and will void the warranty.

The use of components not tested in combination with these units will void the warranty, may make the equipment in violation of state codes, may create a hazard and may ruin the equipment.

## !WARNING - SHOCK HAZARD!

TO PREVENT THE POSSIBILITY OF SEVERE PERSONAL INJURY, DEATH OR EQUIPMENT DAMAGE DUE TO ELECTRICAL SHOCK, ALWAYS BE SURE THE POWER SUPPLY TO THE APPLIANCE IS DISCONNECTED BEFORE DOING ANY WORK ON THE APPLIANCE. THIS CAN NORMALLY BE ACCOMPLISHED BY SWITCHING THE BREAKER FOR THE AIR CONDITIONER TO OFF, DISCONNECTING ALL EXTERNAL ELECTRICAL CONNECTIONS AND CORDS, SWITCHING ON BOARD ELECTRICAL GENERATORS AND INVERTORS TO OFF, AND REMOVING THE CABLE FROM EACH POSITIVE TERMINAL ON ALL STORAGE AND STARTING BATTERIES.

## DANGER

SOME DIAGNOSTIC TESTING MAY BE DONE ON ENERGIZED CIRCUITS. ELECTRICAL SHOCK CAN OCCUR IF NOT TESTED PROPERLY. TESTING TO BE DONE BY QUALIFIED TECHNICIANS ONLY.

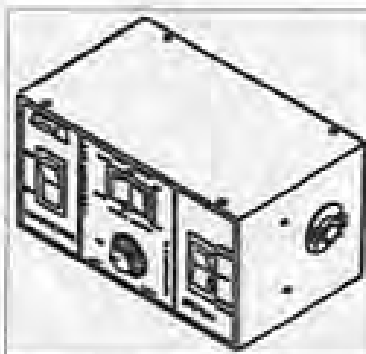

6757-7201

## SERVICE TEST DEVICE

This test device is an invaluable aid in quickly diagnosing repairs to all RV Products roof top air conditioners produced after 1979.

## TABLE OF CONTENTS

### Basic Components and Their Functions Refrigeration System Diagram

I.	Refrigeration Circuit .....	5
II.	Air Handling Circuits .....	6
III.	Electric Power Circuits .....	6
IV.	Tools And Equipment .....	10
V.	Service Problems And Their Solutions .....	13
VI.	Typical Wiring Diagrams .....	20

### QUICK DIAGNOSIS CHART

Note: This chart represents problems with units having mechanical controls - if the air conditioner is equipped with a wall thermostat, please refer to the appropriate manual.

<u>Problem</u>	<u>Possible Causes</u>	<u>Ref. Page Number</u>
Fan And Compressor Will Not Run	No Power 115V	14
	Selector Switch	14
Fan Will Not Run	Selector Switch	17
	Fan Run Capacitor	17
	Motor	17
	Wiring (Mis-wired)	20-21
Compressor Will Not Run	Selector Switch	15
	Thermostat	15
	Low Voltage	15
	Overload	15
	Compressor	15
	Wiring (Mis-wired)	20-21
	PTCR or Potential Relay	16-17
	Start Capacitor	20-21
Run Capacitor		
Cooling Performance		19

**BASIC COMPONENTS AND THEIR FUNCTIONS  
REFRIGERATION SYSTEM DIAGRAM**

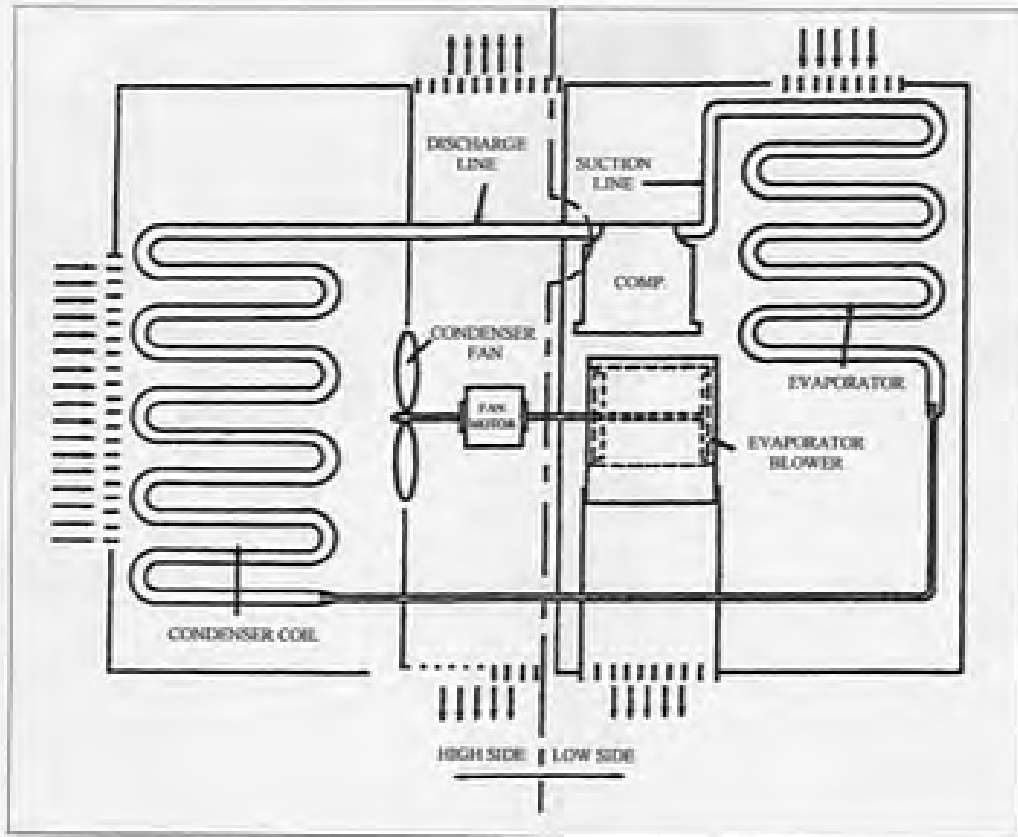

The purpose of this part of the Service Manual is to acquaint the Service Technician with the system components so that when he has a problem, he can intelligently analyze and isolate the problem and efficiently correct it.

## BASIC COMPONENTS AND THEIR FUNCTIONS

### I. REFRIGERANT CIRCUIT

#### 1. Refrigerant Charge

The systems covered by this service manual all use a refrigerant called monochlorodifluoromethane (better known as R-22).

We know that R-22 is not a deadly gas because many of us have breathed it many times and we are still living. But, no one has said that R-22 is completely safe to breathe; so, a wise service technician will always keep a work space well ventilated if R-22 can escape into the air. IF R-22 COMES IN CONTACT WITH ANY OPEN FLAME, PHOSGENE GAS IS CREATED AND ONE SHOULD AVOID BREATHING THE FUMES.

The temperature at which R-22 changes to toxic gases and acids varies with the amount or concentration of water present i.e. the greater the concentration of water, the lower the temperature and vice versa. High temperatures normally exist inside a refrigeration circuit, so we must keep the circuit as absolutely dry as possible to prevent the formation of destructive acids.

Liquid R-22 in the atmosphere will always be at about -41°. Therefore, always wear safety glasses when working with R-22.

Again unburned R-22 is not a deadly gas, so by using reasonable safety precautions, the service technician will not be hurt by it.

In addition to being almost non-toxic, R-22 is non-flammable, non-explosive, non-corrosive and miscible (mixable) with oil. It also has a rather high latent heat value. This means that it must absorb a large amount of heat per lb. to vaporize or change from a liquid to a vapor; and it must give up a large amount of heat per lb. to condense or change from a vapor to a liquid.

#### 2. High and Low Sides

It is customary for air conditioning technicians to use the terms high side and low side. In doing so, we refer to the parts of the refrigeration circuit which, when the system is running, contain high pressure refrigerant (high side) and low pressure refrigerant (low side). The high side of these

systems exists from the discharge port of the compressor to the cap tube. The low side is from the cap tube to the compressor cylinders. The dividing points then are the cap tube and compressor cylinders.

The high side pressure is also referred to as head pressure or condensing pressure, and the low side pressure is also referred to as suction pressure or evaporator pressure.

It is impossible to state the exact pressures that will exist in the high side or low side because those pressures will both vary with different temperature and humidity conditions both inside and outside the recreational vehicle.

#### 3. Capillary Tube (Cap Tube)

The refrigerant enters the cap tube from the condenser as a warm high pressure liquid. As the refrigerant flows through the small diameter cap tube, the pressure drops rather rapidly. As the pressure drops, a tiny amount of the liquid refrigerant will vaporize. This vaporization requires heat which must come from the liquid refrigerant itself - thus the liquid temperature is constantly lowered as it passes through the cap tube. As the refrigerant leaves the cap tube, it is still mostly liquid; however, a small portion has changed to a vapor called flash gas. When the liquid refrigerant passes from the cap tube to the evaporator, it is at low side pressure and will therefore, vaporize at low temperature as it picks up heat from the air being conditioned.

#### 4. Evaporator Coil

The purpose of the finned evaporator coil is to transfer the heat from the warm and moist indoor air to the cold low pressure refrigerant.

As the heat leaves the air, the air temperature drops and some of the moisture in the air condenses from a vapor to a liquid. The liquid water (condensate) is drained onto the roof of the recreational vehicle. As the heat enters the refrigerant in the evaporator, it causes the refrigerant to evaporate (change from a liquid to a vapor). Thus the name - evaporator.

The refrigerant remains at nearly constant temperature (called evaporator temperature or low side saturation temperature) in the evaporator as long as there are both liquid and vapor together. However, near the outlet of the evaporator coil, all of the liquid has boiled (evaporated) away and from there on the temperature of the vapor rises (the vapor becomes superheated). It is necessary that the vapor become superheated because it passes through the suction line to the compressor and the compressor can only pump superheated vapor - any vapor (which might be present if the vapor were not superheated) could cause serious mechanical damage to the compressor.

The power supply to the air conditioner must be wired through a circuit breaker or time delay fuse. The power supply must be 20 amperes and 12 AWG wire minimum. Any size

larger at any time may be used and should be used if the length of the wire is over 32 feet.

## 2) Color Code

The electric power from the electric service panel should be delivered through a 3 conductor cable and the Service Technician should check to be sure the color code is correct. The electrician probably installed the cable with the colors according to code, but don't bet your life on it.

- a) The wire with black insulation is the hot wire and there should be 115 volts (domestic USA) between it and either of the other wires. All switches, fuses, circuit breakers, disconnects, etc. should be in this line.
- b) The wire with the white insulation is the neutral. There should be 115 volts (domestic USA) between the neutral and the hot (black) wire, but there should be 0 volts between the neutral and the ground (the green wire or the frame of the air conditioner). There must be no switches, fuses, disconnects, etc. of any kind in the neutral wire.
- c) The third wire may be covered with green insulation or it may be a bare metal wire. It is the ground wire. There must be 115 volts (domestic USA) between this wire and the hot (black) wire and 0 volts between it and the neutral (white) wire. The ground wire must be securely fastened to the air conditioner cabinet. A ground screw is provided for this purpose.

## 2) Voltage

The voltage (electrical pressure) at the unit should be 115 volts (domestic USA) and all electrical components will perform best at the correct voltage. However, the voltage will vary and the air conditioning system will perform satisfactorily within plus or minus 10% of the rated (115) voltage (domestic USA). Therefore, the voltage has to be between 103.5 volts and 126.5 volts.

## 3. Power Supply - Generated by on-board motor generator

If the power supply for the recreational vehicle is supplied by

an on-board motor generator, its wiring may be identical to the commercial power described above.

There are, however, some motor generators on which both the current carrying leads are insulated from the ground. That is to say, there is no grounded neutral, so there will be 115 volts

(domestic USA) between the black and white leads, but there will be 0 volts between either lead and ground.

**WARNING:** The service technician must keep in mind when checking to make sure that the power is turned off. Check only between the hot (black) lead and the neutral (white) lead.

## 4. Selector Switch - Free Delivery Ceiling Assemblies

The selector switch is mounted on the left side of the interior ceiling assembly. The selector switch allows the unit to be operated on high to low blower only, or high to low blower with compressor operation for cooling. On heating and cooling models, the selector switch can also switch in the electric heater at low blower operation only.

To check the selector switch, remove wires from the terminals and rotate the switch to the proper position and read continuity as follows:

Terminal	Switch Position
L-1-3	Lo Heat
L-1	Lo Fan
L-2	Hi Fan
L-1-4	Lo Cool
L-2-4	Hi Cool

\* If you do not wish to remove the wires from each terminal, disconnect the 9 pin plug from the a/c unit.

## 5. Thermostat (Mechanical Rotary)

The thermostat (temperature controller) is mounted on the right side of the interior ceiling assembly. The thermostat controls the on-off cycle of the compressor when the selector switch is in the cooling position and on heating and cooling models, the on-off cycle of the electric heater when the selector switch is in the heating position. The thermostat is actuated by sensing the temperature of the return air through the vent where the bulb is located. Terminal continuity should make and break if ambient air temperature is between 65 and 90 degrees F.

## 6. Compressor Motor

The compressor motor is located inside the hermetic compressor housing and therefore not accessible for service or visual observation in the field. However, the motor winding

## 5. Suction Line

The suction line is the tube which carries the superheated vapor refrigerant from the evaporator to the compressor.

## 6. Compressor

The compressor is called a hermetic compressor which means that it is completely sealed (welded together). It is, therefore, not internally field serviceable. Inside the compressor housing are basically:

- a) an electric motor which drives the compressor.
- b) a pump which is designed to pump superheated vapor only.
- c) a supply of special refrigeration oil. A small portion of the oil will circulate out through the system with the refrigerant, but will constantly return to the compressor with the refrigerant, so the compressor will not run out of oil.

## 7. Discharge Line

The discharge line carries the refrigerant out of the compressor and to the condenser coil. Remember that as the refrigerant entered the compressor, it was superheated vapor. The refrigerant enters the compressor, where more heat is added and is compressed into a smaller space. The refrigerant, therefore, leaves the compressor highly superheated - so if the discharge line is hot to the touch (burns), don't be surprised - it should be.

## 8. Condenser Coil

The purpose of the finned condenser coil is to transfer heat from the high pressure refrigerant to the warm outdoor air. As the outdoor air passes over the coil, the heat transfer will cause the air temperature to rise. Thus the condenser discharge air will be several degrees warmer than the condenser entering air.

As the refrigerant passes through the first few tubes of the condenser, its temperature will be lowered or it will be de-superheated. After the refrigerant is de-superheated, it will begin to condense or change from a vapor to a liquid and will remain at a nearly constant temperature throughout almost all of the remainder of the coil. This temperature is called the condensing temperature or high side saturation temperature and will always be higher than the condenser entering air temperature.

Near the bottom of the condenser, the refrigerant will all be condensed to a liquid and from there on its temperature will drop to more nearly the temperature of the outside air. After the temperature of the refrigerant drops below condensing or

saturation temperature, we call its condition sub-cooled liquid.

During all of the three processes in the condenser (de-superheating, condensing, sub-cooling), the refrigerant gives up heat; but most of the heat is given up during the condensing process.

## II. AIR HANDLING CIRCUITS

### 1. Motors and Fans

One motor turns both the condenser fan blade and evaporator air blower. The condenser (outdoor) fan is an axial flow (propeller) type and the evaporator (indoor) fan or blower is a centrifugal (squirrel cage) type.

### 2. Filters

The filters should always be in place when the system is running. More important than their purpose of cleaning the air in the living space is the protection the filters give the evaporator coil. Without filters, a wet evaporator coil will quickly stop up so that adequate air cannot pass through it. Filters must be installed to completely fill the filter rack so that no air can flow around them or by-pass them and carry dust, lint, etc. to the evaporator. To clean an evaporator that has not been properly protected by its filter, the entire unit must be removed from the recreational vehicle and the coil cleaned with special detergent and water.

## III. ELECTRIC POWER CIRCUITS

### 1. Safety

Voltage (electrical pressure), whether high or low, will not hurt you. It is the current through vital parts of your body that does the damage, and under the right conditions, 115 volts (domestic USA) is plenty to drive a deadly dose of current (amperes) through your body.

Another imminent danger from electric shocks in addition to electrocution is reaction. An electrical shock causes uncontrollable muscular contractions which can cause further injuries.

Remember that electricity can be very dangerous, but you can safely work with it. In order to be safe, you must know what you are doing. You must work deliberately and carefully. You must think safety before each move.

### THINK SAFETY

### 2. Power Supply - from Commercial Utility

#### 1) Wire Size

condition can be analyzed by using an ohm meter. Be sure to remove all the leads from the compressor terminals before making this check.

- 1) If the resistance between any two terminals is 0 ohms, the motor windings are shorted.
- 2) If the resistance between any terminal and the compressor housing is anything but infinity, the winding is grounded.
- 3) If the resistance between any two terminals is infinity, the winding is open.

On a good compressor, the highest resistance will be between the R (run) and S (start) terminals. The lowest resistance will be between the C (common) and R (run) terminals. The intermediate resistance will be between the C (common) and S (start) terminals. Notice that compressors have the identification of the terminals marked on either the terminal cover or on the compressor housing.

### 7. Overload Switch

Mounted on the outside of the compressor housing is a two terminal overload switch. Note: We have a few models with internal overloads that are non-serviceable. The switch is connected in series with the common terminal, so if the switch opens, it will cut the power to the compressor motor. The switch will open as the result of either or both of two conditions that could be harmful to the compressor.

#### 1) High Amperes (Current)

The switch contains a heater which increases in temperature as the current increases. The higher temperature warps the switch and will cause it to open before the windings reach a dangerous temperature.

#### 2) High Temperature (Thermal)

The switch is clamped tightly against the compressor housing and located close to the windings. Therefore, as the windings reach a higher temperature, it takes less current to cause the switch to open.

As can be seen, the switch is always affected by a combination of current to the compressor and winding temperature.

### 8. Fan Motor

The air conditioning unit has one double end shaft fan motor. On one shaft end is mounted a centrifugal or squirrel cage blower which draws air (return air) out of the recreational vehicle and blows the conditioned air down into the recreational vehicle. On the other end is mounted an axial flow or propeller type fan which circulates outdoor air

through the condenser coil.

\* Some models use a squirrel cage on both ends of the motor.

An important step in installing a replacement fan motor is to check the direction of rotation before it is installed. On all models, the condenser fan pulls the air through the coil.

### Fan Motor Check Procedure

If a fan motor refuses to perform properly, it can be checked in the following manner:

9. Be sure the motor leads are connected to the proper points –
  - a) The black wire from the motor connects to a black wire inside a wire nut then the black wire connects through the disconnect plug to the selector switch. The red wire from the motor connects to a red wire in a wire nut then the red wire connects through the disconnect plug to the selector switch.

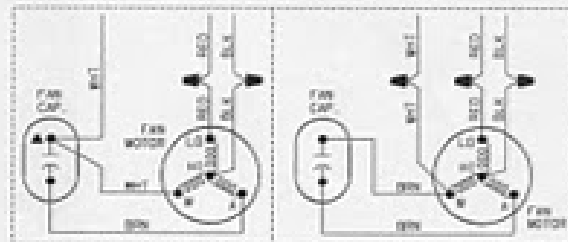

- b) The white wire from the motor connects to the fan capacitor or a white wire in a wire nut then the white wire connects through the disconnect plug to the thermostat.
- c) The brown wires from the motor connect to the fan capacitor.

2. To check the motor winding resistance carefully, check the resistance between each of the wires and ground (preferably a copper refrigerant tube for a good connection). These readings must be infinity. Any continuity means the windings are grounded.

If there is a reading of 0 between any two leads, the motor is shorted and is no good. If there is a reading of infinity (no meter reading at all) between any two leads, the winding is open and the motor is no good.

Note: A motor with 2 brown leads will have an  $\infty$  reading between 1 brown wire and either the black or white wire.



## 9. Run Capacitors

The purpose of the run capacitors is to give the motors starting torque and to maintain high power factor during running. The run capacitors are always connected between the start and run or main terminals of the motor.

On some older models, one of the terminals of the run capacitors will have a red dot (the identified terminal). The identified terminal should always be connected to the run or main terminal of the motor and to the neutral line.

### CAPACITORS

#### Capacitor Check

There are several capacitor test devices available. The ohm meter is one of them. The ohm meter cannot verify a capacitor's MFD (microfarad) value. However, the following procedures will show you how to use an ohm meter to determine if the capacitor is good, open, shorted or grounded.

Before testing any capacitor, always perform the following procedure:

- a. This test must be done with a analog type meter.
- b) Disconnect all electrical power to the air conditioner.
- c) Discharge the capacitor with a 20,000 ohm (approx. 3 watt) resistor or larger.
- d) You may discharge capacitors with a standard volt meter if you use a scale over 500 volts and touch the leads (one lead to each side of the capacitor). The volt meter will discharge the capacitor.
- e) Identify and disconnect the wiring from the capacitor.
- f) Set and zero the ohm meter on the "highest" scale.

When testing for a good, open or shorted capacitor, perform the following checks: Place the ohm meter leads across the capacitor terminals (one lead on each terminal) and perform a continuity test. Then observe the action of the meter needle or indicator. Reverse the leads and test again. The result should be the same. Note: If the capacitor had not been properly discharged, a false reading could be indicated on the first test. Always test several times (reversing the leads with each test). This will verify the capacitor's condition.

#### Good Capacitor

If the capacitor is good, the indicator will move from infinity (the left side), towards zero ohms and slowly return back to infinity. Reverse the leads and test again. The result should be the same.

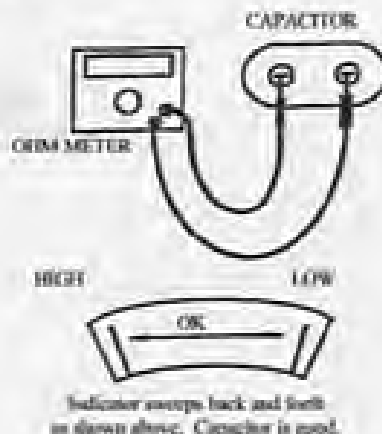

#### Open Capacitor

If the capacitor is open, the indicator will show no deflection or movement. Reverse the leads and test again. If there is no indicator movement on the second test, the capacitor is open. Open capacitors are defective and must be replaced.

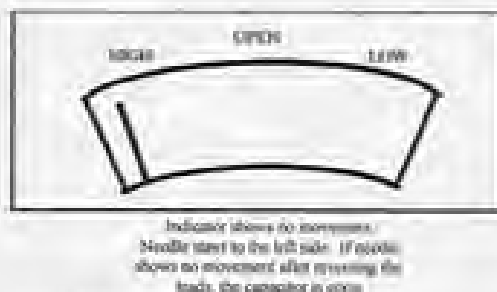

#### Shorted Capacitor

If the capacitor is shorted, the indicator will move towards and sometimes hit zero ohms, and will stay there. This indicates a completed circuit through the inside of the capacitor (shorted). Shorted capacitors are defective and must be replaced.



## 1. Ammeter And Its Use

An ammeter is an instrument for measuring electric current. Current electricity is actually electrons moving from one atom to another through a conductor. In order to intelligently use electricity, we must have a measurement of a quantity of electrons.

The instrument we use to measure the number of amperes is called an ammeter. These instruments have snap-around jaws that will allow you to read the current through a wire without detaching the wire from the system. Always buy an energizer with the instrument so that you can accurately read low current circuits. These meters also have volt meter and ohm meter attachments so they are an excellent multi-purpose meter. **NO TECHNICIAN SHOULD EVER ATTEMPT A SERVICE CALL WITHOUT ONE.**

## 2. Ohm Meter And Its Use

An ohm meter or resistance meter indicates the resistance of a circuit to current flow. Just as every water pipe or hose has a resistance to water flow or every air duct has resistance to air flow, so does every wire have resistance to the flow of electric current. There is no such thing as a conductor with zero resistance to electron flow although sometimes we will be measuring the resistance of a conductor and find it so low that we cannot detect any resistance; so we call the resistance zero. What we mean is that the resistance is so low that we can't find it. The amount of resistance or holding back force of the wire or conductor depends on:

- a) The material the conductor is made of; silver, copper and aluminum are good conductors. This means that in any given size wire, these materials will have low resistance. Silver has the lowest resistance, but its price is too high, so we use copper.
- b) The diameter of the wire. The longer the wire, the greater the resistance because there is more metal to carry the current.
- c) The length of the wire. The longer the wire, the greater the resistance. In fact, the resistance of any wire varies in direct ratio with its length.
- d) The temperature of the conductor. The resistance of most - but not all - conductors increases as the temperature of the conductor rises. Hence, the resistance of the filament of a light bulb is rather low when it is turned off and cooled down; but when the power is turned on, the filament temperature increases until it glows and the resistance increases.

Resistance to electron flow is measured in units called ohms. An ohm is actually the amount of resistance that will hold the current down to one ampere (one coulomb of electrons per

second) if there is one volt of pressure.

An ohm meter is really a resistance meter that is calibrated in ohms. The ohm meter has its own power source, a small dry cell, which forces a small amount of current through a conductor via the meter probes. The meter must be calibrated to read 0 ohms when the probes are touched together each time it is used because as the dry cell loses its charge, the meter will get out of calibration.

If the probes of an ohm meter are attached to the terminals of a closed switch, the meter will read 0. This means that there is virtually no resistance to current flow through the switch. Now, if the switch is turned off, the contacts will be open and there will be very high resistance. In fact, the resistance is so high it is an infinite number of ohms so we call this reading infinity.

With the switch open, there is not a continuous conductor through it so we say there is no continuity. If the ohm meter reads anything other than infinity, we say we do have continuity. As can be seen from the above example, an ohm meter is a good instrument for checking to see if the contacts of a switch, thermostat, relay, overload, etc. are closing properly or creating continuity.

The previous examples show two conditions that can be detected by an ohm meter; (1) a closed, 0 resistance conductor and (2) an open circuit which reads infinity or no continuity. Now let's consider something in between - the windings of a compressor. If we attach the ohm meter probes to the common and run terminals of the compressor, we can read the resistance of the main or run winding. The winding is a solid and continuous copper wire so there will be continuity through it; but instead of 0 ohms, as there was through the closed switch, this winding is of such small wire and so long that there is resistance. Now let's attach the probes to the common and start terminals to get the resistance of the start of phase winding. Since this winding is made of even smaller and longer wire, its resistance will be greater than the main winding. Now let's attach the probes to the start and run terminals to read the resistance through both windings. This reading is the same number of ohms as the total of the two previous readings.

If the reading between any two terminals is infinity, we can determine that the winding is open - the wire is broken or burned in two. If the reading between any two terminals is 0 ohms, the insulation is burned off the winding and we can determine that the compressor motor is shorted. If the reading between any terminal and the compressor housing is anything except infinity, we can determine that the compressor motor is grounded. An open, shorted or grounded compressor must be replaced. The fan motor windings can be checked by the same method as the compressor motor winding. The only difference being that the windings are made of smaller gauge wire and the resistance will be higher. The fan motor has no push on

### Grounded Capacitor

When testing for a grounded capacitor, perform a continuity check between each terminal on the capacitor and the bare metal of the capacitor case. Any indication of a circuit (constant resistance) from either terminal to case, indicates a grounded capacitor. Grounded capacitors are defective and must be replaced.

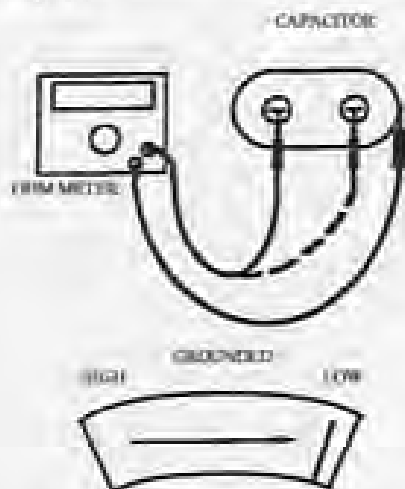

Indicator moves to the right side of the scale and stays there (indicating a completed circuit). The capacitor is grounded.

### 10. Start Capacitor

Most models use a start capacitor and a start relay to give the compressor high starting torque. The compressor will, therefore, start against normal pressure difference (head pressure minus suction pressure) even when shut down for a short period of time. The start relay will disconnect the start capacitor when the motor reaches approximately 75% running speed.

#### 11. (A) Start (Potential) Relay

The start relay consists of -

- 1) Normally closed contacts internally between terminals #1 and #2 which switch in the start capacitor in parallel to the run capacitor during shut down and then switch out the start capacitor when the motor reaches approximately 75% normal running speed.
- 2) A high voltage coil internally between terminals #5 and #2 to actuate the contacts. The coil is too weak on line voltage to actuate the contacts, but it is

connected in series with the start winding and it gets the generated voltage of the start winding portion of the compressor motor. This generated voltage is much higher than line voltage and varies with the speed of the rotor. Therefore, since the relay is designed to open the contacts at 75% of normal running voltage (measured between terminals #5 and #2), the contacts will open (thus disconnect the start capacitor) at approximately 75% of normal running speed.

#### 11. (B) Positive Temperature Coefficient Resistor (Commonly Known As PTCR Start Device)

The resistor acts like a potential relay in that it takes the start capacitor out of the start circuit, but uses resistance of electrical flow (back EMF from compressor) instead of opening a set of contacts. The service person should be careful handling the resistors. They will be hot during operation (up to 160 degrees F). The air conditioner needs to be off for 3-5 minutes during cycle time and when servicing to let the resistor cool down.

#### 12. Heating Element

The heating element is a resistance heater of 1600 watts (5600 BTU/H) capacity and is connected across the line when the selector is set for heating and the thermostat is calling for heat. The current draw of the heater (element only) will be 13.3 amperes at 120 volts (domestic USA models).

#### 13. Limit Switch

The limit switch is a safety switch and is mounted in the heating element frame. It will open and break the circuit on temperature rise in case the air flow through the heater becomes low enough to cause the heater to overheat.

## IV. TOOLS AND EQUIPMENT

In order to service the equipment covered by this Service Manual, a technician will need all the common mechanics tools such as wrenches, screwdrivers, hammers, etc.

In addition to the common mechanics tools, in order to do refrigeration and electrical work, he will need special tools and equipment such as:

1. Ammeter
2. Ohm Meter
3. Volt Meter
4. Refrigerant Recovery Equipment
5. Charging Cylinder
6. Vacuum Pump
7. Vacuum Gauge
8. Leak Detector
9. Brazing Equipment
10. Gauge Manifold

terminals, but we know by referring to the wiring diagram, that the black wire is the common terminal, the red wire is the start terminal and the white wire is the run terminal.

Notice that when we are using an ohm meter, the power must be turned off! It is also important to disconnect all wires from a conductor being checked with an ohm meter to prevent any chance of feedback.

An Ammeter is an essential instrument to have and use, and is a real bargain because it is three instruments in one.

### 3. Volt Meter And Its Use

A volt meter measures the amount of electrical pressure in an electrical conductor just as a tire gauge measures the amount of air pressure in an automobile tire. If we attach one volt meter probe to the hot line and the other probe to the neutral line of a standard circuit, the meter reading will be the electromotive (electron moving) force or pressure difference between the two lines. This is the amount of pressure we have available to push electricity (electrons) through the light bulbs to make the motors turn, etc. In the above example, we should find approximately 115 volts (domestic USA models) or units of electrical pressure. Remember, a volt meter always registers the voltage pressure difference between two points.

#### CAUTION

A volt meter is used on live circuits so use extreme care. **THINK SAFETY!**

### 4. Refrigerant Recovery Equipment

The Environmental Protection Agency has implemented strict regulations on refrigerant handling and refrigerant recovery equipment.

Check with your local EPA office regarding what type of certification you must have to open or work on the refrigerant sealed system.

In accordance to the Clean Air Act passed in 1980:

1. There shall be no venting of refrigerant into the atmosphere after July 1, 1992.
2. All recovery equipment must meet EPA standards (check with your local office).
3. Technician Certification deadline was November 14, 1993.

### 5. Charging Equipment

The amount of charge to any refrigerant system must be kept

accurate to within a fraction of an ounce to prevent damage to the compressor and insure proper performance. Systems must not be charged to a certain amperage pull. They must not be charged to certain suction line temperature.

The recommended field instrument for charging the right amount of R-22 into the system is either:

1. An electronic scale made especially for charging a/c systems of critical charge. (Note: The charge must not be weighed in with inaccurate bathroom scales, or,
2. A Dial-A-Charge of 5 lb. capacity. Do not use the Dial-A-Charge 10 lb. capacity or any other charging cylinder on which the graduations of the scale are such that the instrument cannot be read accurately.

Follow the charging cylinder manufacturer's instructions carefully.

### 6. Vacuum Pump

It has long been recognized that the worst enemy of a refrigeration system is water. R-22 (and other refrigerants) will break down and change to strong acids at elevated temperatures in the presence of water. The greater the concentration of water, the lower the temperature at which the refrigerant will break down. The only way to remove the water from a system to a satisfactory level is to vaporize it and draw it out of the system with a vacuum pump.

A good quality vacuum pump is one of the finest pieces of machinery there is, so it deserves the best of care. Keep it clean and protected. The oil should be changed each time before it is used.

### 7. Vacuum Gauge

To go with a good vacuum pump, a good quality vacuum gauge must be used. The pump may not pump a good vacuum due to contamination of the oil. Also a leak in the system or service hoses may prevent a deep vacuum from being reached. The length of time that it takes for the pump to evacuate a system will vary with the amount of moisture and air in the system. The gauge will not show a deep vacuum (under 200 microns) until all of the water has been boiled out. Also, if a system has even a very small leak, it cannot be properly evacuated. So a good gauge will indicate whether or not we have a dry system with no leaks. The vacuum gauge to get is a thermistor type. Remember, when you buy a gauge, it must be read accurately at 200 microns and below.

### 8. Leak Detectors

It is strongly recommended that a Service Technician carry two types of leak detectors at all times.

1. Most all electronic leak detectors are very sensitive and are field reliable. A word of warning – do not “give it a whiff of refrigerant” as a test to see if it is working because its sensitivity and life expectancy diminishes as it is exposed to refrigerant.

Always use this instrument as a final leak test. It will find the very small leaks that take several weeks to cause trouble but will cause a burn out if not repaired.

2. With an electronic leak detector, a leak is sometimes difficult to pinpoint – you can find the general area of the leak, but not its exact location. A soap bubble type leak detector will show its exact location.

#### 9. Brazing Equipment

For all brazing work, you need a torch type that burns with a soft flame that is easy to control and is hot enough for brazing refrigerant tubes. The easiest and most satisfactory brazing rod to use is Sil Flo or Stay Silv – 15% silver. This rod can be used to blend with any brazing rod that exists on today’s units.

#### CAUTION

Always have a dry powder fire extinguisher with you (not in your truck) while you are brazing.

#### 10. Gauge Manifold

Gauge manifold sets are used for checking pressures, evacuating and recharging the a/c.

Basically a gauge manifold consists of a compound gauge and a high pressure gauge mounted on a manifold with hand valves to isolate the common (center) connection or open it to either side as desired.

Connecting the gauge manifold to the system is necessary to read the suction pressure and head pressure, and to intelligently analyze a system for malfunction. Any service technician will naturally hesitate to connect his gauges because to do so involves opening a hermetic system.

The R-22 that is in the system will have to be released to a refrigerant recovery system (see equipment manufacturer’s guide for system access information).

### V. SERVICE PROBLEMS AND THEIR SOLUTIONS

When a recreational vehicle owner calls for service on his air conditioner, let him explain exactly what has happened; when the air conditioner first gave him trouble, what is sounded

like, how hot was the weather, what time was it, etc. He is a rich source of information. Listen to everything he says. You will compliment him and he will help you to identify the problem.

Always be alert for a customer who has been working on his own equipment. Check all wiring and visually inspect all motors, fans, capacitors, dampers, tubing, etc.

When a Service Technician gets all the information he can from the customer, he then examines the equipment for more facts that might lead to the cause of the problem (always be on the alert for loose or burned wires, smoke stains, kinked or broken tubes, oil stains, etc. – those things which would obviously cause a malfunction or would indicate a malfunction).

After he gets all the available information together, he starts asking himself questions:

“What causes has the information eliminated and why?” (For instance, if the compressor is running, that eliminates a tripped circuit breaker as the cause of the problem.)

“What are the possible causes?”

“Which of the possible causes are the most probable ones?”

“How should I check them out?”

For each of his questions, he expects an answer. Since there is no one else around qualified to answer his questions, he must supply the answers himself.

As his questions and answers eliminate the possible causes one by one, he will soon identify the reason for the malfunction. Then he can repair it.

ISOLATE THE PROBLEM - THE SOLUTION IS SIMPLE.

#### Problem

1. Nothing runs.

The customer turns the selector switch to the “Cool” position and the thermostat to a low temperature (below room temperature) and nothing happens. This is surely a serious problem, but it is usually the easiest to correct.

Question: “What are the possible causes?”

Answer:

1. “The power supply could be dead.” Check for open circuit breaker of fuse at service panel. Check for 115 volts domestic USA models or 240 volts export/overseas models between hot line (black) and neutral (white) at power entrance at unit.

2. "The selector switch could be open." Rotate the selector switch and check for continuity between the appropriate terminals.

<u>Terminals</u>	<u>Switch Position</u>
L-1-3	Lo Heat
L-1	Lo Fan
L-2	Hi Fan
L-1-4	Lo Cool
L-2-4	Hi Cool

Notice that when we are using an ohm meter, the **power must be turned off**. It is also important to disconnect all wires from a conductor being checked with an ohm meter to prevent any chance of feedback.

#### Problem

#### 2. Inadequate Cooling

The customer says he gets inadequate cooling for a while after he turns the system on and then it seems to quit cooling completely. As soon as the housing is removed from the unit with the system running, we observe that the suction line is coated with frost.

Question: "Could the system be low on charge or the cap tube plugged?"

Answer: "No."

Question: "Why not?"

Answer: "Because, if it were low on charge or if the cap tube was even partially plugged, the low side would be starved for refrigerant and therefore, the suction line would be warm. Also, the compressor housing would be hot."

Question: "Then why isn't it cooling properly?"

Answer: "Because the evaporator is not picking up the heat load."

Question: "What could cause the evaporator to not pick up the heat load?"

Answer: (possible causes and repairs)

1. "The filter could be dirty."

This is the most probable cause and, of course, the easiest to check and correct.

2. "The ceiling assembly louvers could be completely closed."

This problem is easy to find and it is usually corrected by opening the discharge louvers.

3. "The fan could be at fault."

A mechanical problem such as the wheel (squirrel cage) loose on the shaft is usually rather obvious. Checking why a fan motor does not come up to speed is a little more involved.

- A) Seized bearings – This does not often occur; but if it does, a few drops of oil will usually free them temporarily. If the shaft is scored in the bearings, it will soon tighten up again. Now is the time to replace the motor.
- b) Partially burned motor windings – See fan motor check procedure.
- c) Shorted or open capacitor – See capacitor test.

4. "The evaporator coil face could be coated with lint, dirt, etc."

Dirt or lint on the coil will restrict the flow of air through the coil and the unit must be removed from the recreational vehicle and the coil must be thoroughly cleaned with strong detergent (Coil X, Calclean, etc.) and water. Be sure to protect the fan motor and electrical controls during cleaning by covering them with polyethylene sheet. After the system is cleaned, allow it to thoroughly dry for several hours (before turning it on) to prevent electrical shorts.

Before system is put back into operation, be sure the filter is properly installed to prevent recurrence of dirty coil.

#### Problem

3. No compressor (Does not try to start).

The customer turns the selector switch to "Cool" and the thermostat to a low temperature (below room temperature). The fan runs OK, but the unit does not cool. When the unit housing is removed, we observe that the compressor does not run and it does not hum (the compressor is completely dead).

Question: "What are the possible causes?"

Answer:

1. "The selector switch may be open to the compressor."  
  
Rotate the switch to the compressor position and check the selector switch terminals (1. to 4) with ohm meter for continuity.
2. "Thermostat may be open."  
  
Rotate the switch and check the thermostat terminals with ohm meter. The contacts should open and close if the ambient air temperatures are between 60 and 90 degrees F.
3. "Overload switch may be open."  
  
Check around overload switch with ohm meter.
4. "Compressor winding may be open."  
  
Check out compressor windings with ohm meter (See page 8).  
  
Notice that when we are using an ohm meter, the power must be turned off. It is also important to disconnect all wires from a conductor being checked with an ohm meter to prevent any chance of feedback.

#### Problem

#### 4. No Cooling.

The customer turns the selector switch to "Cool" and the thermostat to a low temperature (below room temperature). The fan runs OK, but the unit does not cool. When the unit housing is removed, we observe that the compressor does not run; however, it periodically hums for 15 to 30 seconds.

Question: "Could the cause of the trouble be the circuit breaker or fuse, the selector switch or the thermostat?"

Answer: "No - because we know that power is getting to the common and run terminals of the compressor to make it hum and the Thermal-Current Overload switch is breaking the circuit to protect the compressor from burn out."

Question: "What are the possible causes of the problem?"

Answer: The possible causes are -

1. "The voltage could be low -"
  - a) Check the voltage between #1 on the overload switch and the "R" terminal of the compressor while it is not humming. This voltage must be 115 volts domestic USA models or 240 volts export/overseas models. No less than minus 10% is allowable.
  - b) Check the voltage from "C" or "R" of the compressor while it is humming (trying to start). The latter reading will probably be lower, but it still must be 103.5 volts minimum domestic USA or 216 volts minimum export/overseas models.

If the first reading is above 103.5V domestic USA and the second is under 103.5V domestic USA, there is too much voltage drop in the lines - a situation which must be corrected for the air conditioner to perform safely and satisfactorily.

2. "A capacitor could be shorted, weak or open."

#### Turn the power off.

Caution - There is always a chance that a capacitor is holding a residual charge, so before touching a terminal, discharge the capacitor as explained earlier in this booklet.

Remove capacitors, visually examine them and test them per instructions given in earlier section on capacitor testing (See page 9).

If the capacitors test OK, replace them and carefully reconnect the wires. Be sure the wires are connected to the right terminals.

3. "Start relay contacts could be open - " if so equipped.  
  
Turn off all power, then check for continuity with ohm meter between terminals 1 & 2.
4. "Compressor start winding could be open or grounded."  
  
Check compressor windings per instructions. See the section on the compressors (See page 8).
5. "Compressor could be mechanically stuck."  
  
This very rarely occurs and when it does, it is usually after a lengthy shutdown. This should be considered only after all the above possible causes have been positively eliminated. To free a stuck compressor, use your hermetic analyzer according to the manufacturers instructions.

**Problem**

5. Compressor trips breaker or thermal current overload.

Compressor trips circuit breaker or thermal current overload immediately (no hum). Note that this problem is different from the previous one in that in the previous problem, the compressor did hum for several seconds.

With the selector switch in "Fan Only" position, the fan works OK.

Question: "What are the possible causes?"

Answer:

1. "The compressor winding is shorted or grounded, or"
2. "The circuit breaker or thermal current overload is weak, (this rarely occurs, but it can occur after the switch has tripped out many times. The only repair is to replace the circuit breaker or overload)."

Question: "How do I repair it?"

Answer:

1. "With the power turned off, check the resistance between all three compressor terminals and ground. If any continuity is found, locate the ground and correct it."
2. "Check compressor windings per instructions (See page 8)."
3. "If the above checks are OK, replace the switch that is tripping out."

**Problem**

6. Compressor makes loud growling noise.

Customer has turned the unit off and called for service because he believes the air conditioner is surely burning up since it makes such a loud noise. On inspection, we find that the compressor starts but draws high current and continues to make the growling noise until the thermal current overload trips out.

Question: "Which components can we determine are working OK from the symptoms?"

Answer:

1. "The power is getting to the compressor."
2. "The start circuit is starting the compressor OK."
3. "The capacitors and relay are providing the starting torque."

Question: "Then why the noise?"

Answer: "The start capacitor is staying in the circuit and the compressor is running with too much capacitance. This condition is caused by; 1) the compressor does not come up to speed and does not supply adequate voltage to actuate the potential relay, or 2) the potential relay contacts are welded shut, or 3) the potential relay coil is open."

Question: "How do I repair it?"

Answer:

1. "Check the voltage between "C" and "R" terminals of the compressor. Low voltage can cause the compressor to not come up to speed."
2. "Check out the potential relay with hermetic analyzer or try a new potential relay."
3. "Check compressor windings per instructions."

**Problem**

7. Fan Vibration.

The customer complains that the unit vibrates excessively. We turn selector switch to fan/low or fan/high and the vibrations are not appreciably reduced (we quickly eliminate the compressor as the source of vibration).

The fan motor and fans were carefully balanced at the factory, but they are fragile enough that they can be bent by rough handling.

Question: "How can I determine which part of the fan assembly is causing the vibration?"

Answer: "By removing the fan wheels one at a time and running it each time until the vibration stops. To correct the problem, replace the faulty part."

**Problem**

8. Fan won't run.



The customer turns the system to fan/low or fan/high and nothing happens. When he turns the selector switch to "Cool", the compressor starts but still no fan.

**Question:** "What could cause the fan to be dead?"

**Answer:**

1. "The selector switch could be open."

The safest way to check a selector switch is to turn off all power, remove the wires and with an ohm meter, check for continuity between terminals L&1 for low speed fan connection and terminals L&2 for high speed fan connection. The meter should read 0 ohms.

<u>Terminals</u>	<u>Switch Position</u>
------------------	------------------------

L-1-3	Lo Heat
-------	---------

L-1	Lo Fan
-----	--------

L-2	Hi Fan
-----	--------

L-1-4	Lo Cool
-------	---------

L-2-4	Hi Cool
-------	---------

2. "Fan motor windings could be open, shorted or grounded."

Be sure power is off. Check motor windings per instructions (See page 8).

3. The electrical circuit to the fan motor leads could be open. Check all connections (including wire nuts) to the fan motor red, black and white wires.

4. "Fan capacitor may be shorted, weak or open."

To check fan capacitor, follow same procedure that is outlined for compressor run capacitors (See page 9).

#### **Problem**

9. Compressor runs but won't pump.

The customer turns the selector to a "Cool" position and the thermostat to a low temperature setting (below room temperature). The fan runs OK, but the unit does not cool. On examination we find that the compressor does run. It runs quietly and smoothly. We check the compressor current and find that it is below the FLA rating. The evaporator is warm, the suction line is warm. There are two possible problems, either the compressor valves are broken or the unit is completely out of charge. At this point, you must break into the system to locate the problem.

#### **Problem**

10. Compressor cycling off and on.

The customer says he gets inadequate cooling even though he has several times set the thermostat down to call for a lower temperature until it is now all the way down to the lowest possible setting.

On investigation, we find that the compressor is cycling off and on.

**Question:** "What could cause the compressor to cycle off and on?"

**Answer:** "Two things."

1. "The thermostat is out of calibration. Turn off power. Check with ohm meter."

2. "The compressor is cycling on the thermal current overload."

With the power on, check the voltage between the terminals of the overload while the compressor is not running. If the meter reads 115 volts domestic USA models or 240 volts export/overseas models, the compressor is cycling on this switch (see page 8 for description and function of this switch).

**Question:** "What could cause the switch to open and close?"

**Answer:** "Compressor is running hot or compressor is drawing excess current or both."

**Check by:**

1. Feeling the compressor dome - it will normally (during warm weather - above 85°) be too hot to be comfortable if you keep your hand on it. If it is burning hot, it is probably overheating. The normal compressor housing temperature varies with outside temperature and evaporator load so determining whether or not it is too high is a matter of judgement based on experience.

2. Measuring the current (amperes) through the black wire which leads from #5 on the potential relay to the overload switch. This current may be compared to the unit FLA rating.

Remember that the overload switch is sensitive to both high temperature and high current. Since this is true, we can't specify a definite temperature or amperage at which the switch will open. As the temperature rises, the current at which the switch will open goes down. As the temperature goes down, the current at which the switch will open goes up.

Question: "What could cause the compressor to draw overcurrent or to overheat?"

Answer:

1. "Dirty condenser coil."

Check the appearance of the coil. If it is coated with lint, cottonwood fuzz, leaves, etc., it is insulated and it cannot give up its heat to the outside air. A dirty condenser will cause high head pressure which will in turn cause both high current draw and high temperature at the compressor.

2. "Condenser fan does not come up to speed."

Check fan blade, fan motor and capacitor.

3. "High or low voltage."

High voltage can drive excessive current through the motor windings. Low voltage can cause the compressor to slow down, overload and draw excessive current. Check the voltage between "C" and "R" terminals on the compressor while it is running. The volt meter must read between 103.5 volts and 126.5 volts (domestic USA models - plus or minus 10%).

4. "Overcharge or non-condensables in the system."

Either an overcharge of refrigerant or non-condensables in the system will cause high head pressure and consequently, excessive current. Be especially suspicious if you discover evidence of the

system having been open (service valves in the system, extra pinch off marks, etc.).

The indications of overcharge are:

- Overcurrent which may be checked as previously outlined.
- Cooler than normal suction line. With an overcharge, the suction line will usually sweat all the way to the compressor.
- Cooler than normal discharge line. The discharge line should be highly superheated and therefore, at high temperature.

Feeling lines with your fingers is a very inexact method of gathering information and cannot be considered accurate. So use this information only to form preliminary judgments in your diagnosis of trouble and consider as many indicators as possible

in coming to a conclusion.

The indications of non-condensables in the system are:

- Overcurrent
- Higher than normal discharge line temperature
- Higher than normal liquid line temperature
- Higher than normal compressor temperature

5. "Low Charge."

This very rarely occurs and should be considered **only** after all other possible causes have been positively eliminated.

The compressor is dependent on a good supply of cool suction gas for cooling. If the system charge is low, there will be less than a normal amount of refrigerant passing through the compressor, less compressor heat will be carried away by the refrigerant, and therefore, the compressor will overheat. **NOTE - LOW CHARGE WILL NOT CAUSE OVERCURRENT.** It will, in fact, cause the current to be low.

Indicators of low charge are:

- The evaporator will be starved for liquid refrigerant so the suction line and a portion of the evaporator coil will be warmer than normal. This is the condition we refer to as too much superheat. How much of the evaporator coil will be starved for liquid refrigerant depends on the degree of undercharge.
- The active portion of the evaporator coil which does have some liquid refrigerant will be colder than normal and many times will frost because the suction pressure will be low. How much of the coil is active depends on the degree of undercharge.
- The compressor temperature will be noticeably higher than normal.

Note: Low charge situations may be mimicked by problems such as dirty filters, dirty evaporator coils, air flow restrictions and low load conditions. Do not attempt to tap into the system unless you are specifically trained in refrigeration system repairs.

6. "Plugged up cap tube."

A cap tube can become stopped up by oil sludge or contaminants in the system. This will only occur if the system has been open to allow moisture or other contaminants to enter the system or if the compressor has been overheated for a lengthy period of time.

It is difficult to determine the difference between a stopped up cap tube and a low charge because the symptoms will be nearly the same.

To repair either a low charge or stopped up cap tube, we will have to install service valves and attach gauge manifold. If after the correct amount of refrigerant has been charged into the system, and it has low charge symptoms, we will know the cap tube is plugged and will have to be replaced.

**Problem**

12. No heat - Heat Strip.

The customer says that he has turned the selector switch to "Heat" position and the blower works OK, but no heat.

**Question:** "What are the possible causes of "no heat" problem?"

- Answer:**
1. "The limit switch or the heating element could be open." Check with continuity.
  2. "The selector switch could be open (See page 7)."
  3. "The thermostat could be open (See page 7)."

In all three cases, turn off power and check for continuity with an ohm meter.

**Problem**

13. Cooling Performance Check

Make sure the filters, the evaporator coil and the condenser coils are clean and all supply air registers are open wide.

1. Start the air conditioning unit and allow it to run for at least one-half hour. Possibly longer if it is extremely warm outside (the objective is to saturate the evaporator coil before we begin running a temperature test).
2. With a standard dial type or digital thermometer, measure the temperature of the air immediately

entering the return air grille of the air conditioning unit.

3. Subtract from this temperature the temperature of the air immediately leaving the supply air louvers (if it is a ducted air conditioning unit, use the closest discharge register and make sure the temperature sensing device is measuring supply air temperature only).
4. A properly running air conditioning unit should have a temperature difference of approximately 18 to 22 degrees F. Note: Slightly less temperature differences are possible under extremely humid conditions. (The unit may have to run longer to remove moisture).
5. Temperature differences greater than 22 degrees are possible in warm dry weather. Restricted air flow over the evaporator may also cause greater than 22 degree temperature differences.
6. Compressor running amps should be checked as follows. Note the amperage listed on the air conditioner rating plate (R.L.A) is determined at design conditions only. These conditions are 95 degrees outdoor temperature and 80 degrees indoor temperature.

Since the outdoor temperature is mostly responsible for the amount of compressor amperage, this figure will have to be adjusted for changes in outdoor temperature approximately 1 amp for every 5 degrees in temperature change (from 95 degrees) up or down accordingly.



6798-7XX, 6798A7XX SERIES  
 6799-7XX, 6799A7XX SERIES  
 6799-8XX SERIES  
 AIR CONDITIONERS & CEILING ASSEMBLIES

RECREATION VEHICLE PRODUCTS, INC.  
 P.O. BOX 4020, WICHITA, KS 67204

DANGER! SHOCK HAZARDS DISCONNECT POWER SUPPLY  
 BEFORE SERVICING ANY ELECTRICAL COMPONENT.

AVIS! DÉBRANCHEZ LES FILS ÉLECTRIQUES AVANT L'É  
 INTRETIEN ET DE TOUT COMPARTIMENT OU ORGANES  
 ÉLECTRIQUES.

SUPPLY WIRES 10 AWG. MIN. USE COPPER CONDUCTORS ONLY.

CHECK TERMINAL LOCATIONS FOR CORRECT CONNECTIONS  
 AND SPACING BEFORE OPERATION.

USE TIME DELAY FUSE MAX. AMP 20  
 OR CIRCUIT BREAKER MAX. AMP 20  
 U.L. H.A.C.R. TYPE MAX. AMP 20

	INDICATES IDENTIFIED TERMINAL OF CAPACITOR.
	EXHAUST MOTOR EQUIPPED ON EYE SERIES ONLY.
	INDICATES FIELD WIRING NECESSARY.
	INDICATES FACTORY WIRING.
	INDICATES WIRING FOR EYE SERIES ONLY.

WIRING DIAGRAM FOR 6798 & 6799 SERIES R.V. ROOFTOP AIR CONDITIONER.

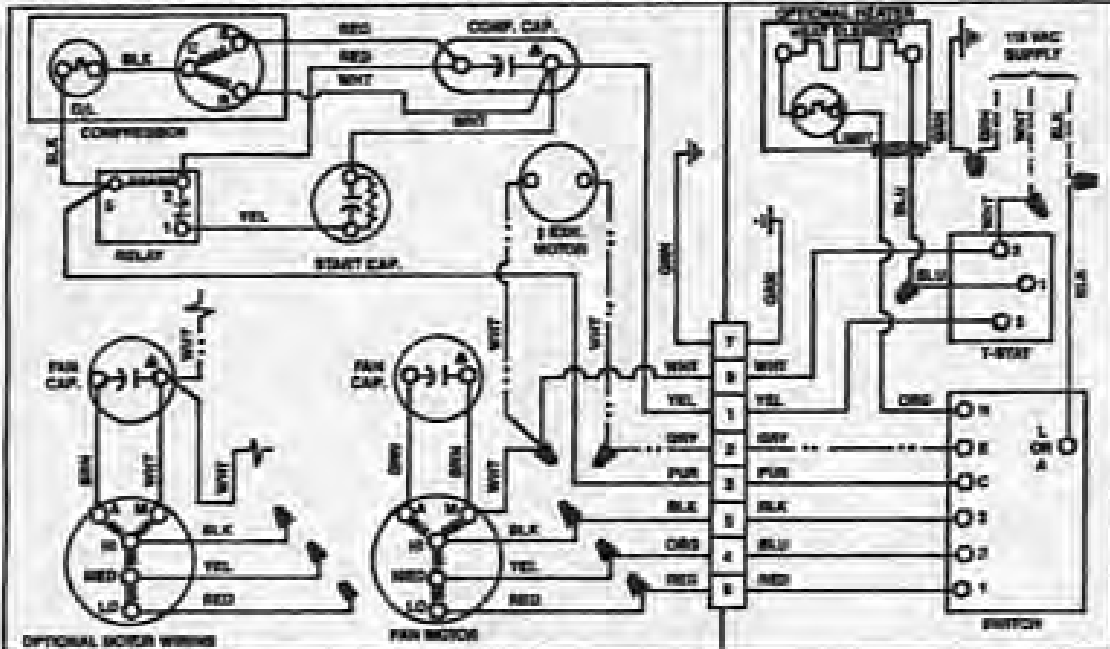

WESCAM Rev. 1 (10-77) P.L.

LITHO IN U.S.A.

**7000 & 8000 SERIES  
6799A8XX SERIES  
6799B8XX SERIES  
AIR CONDITIONERS**

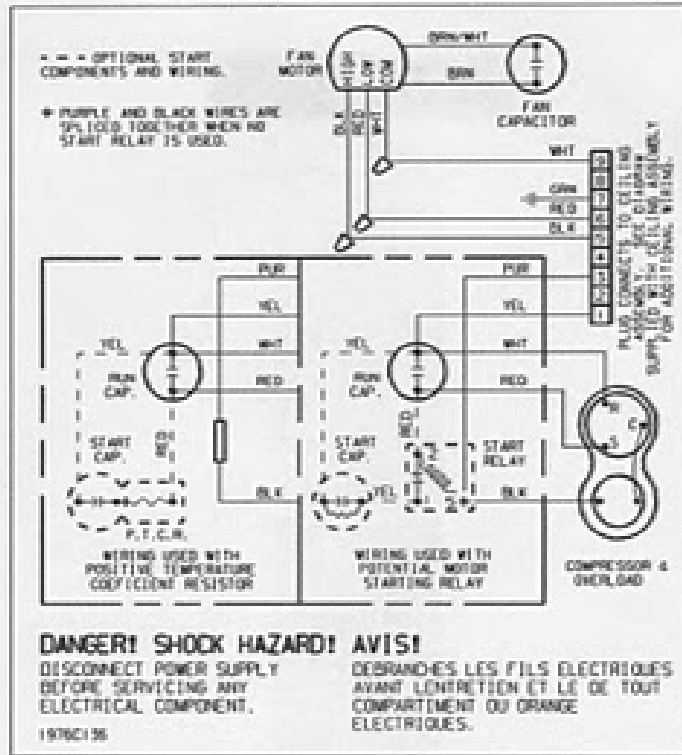

## CEILING ASSEMBLY WIRING DIAGRAMS

### 6759, 7000, 8000 SERIES COOL ONLY

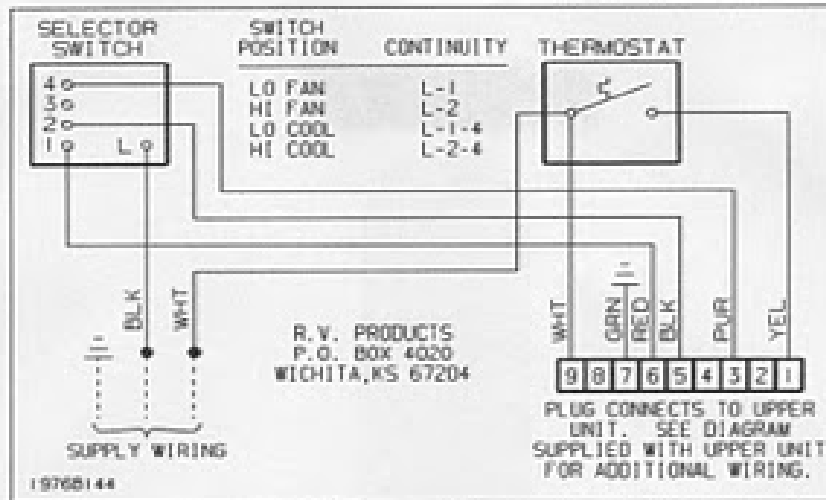

### 6759, 7000, 8000 SERIES HEAT/COOL

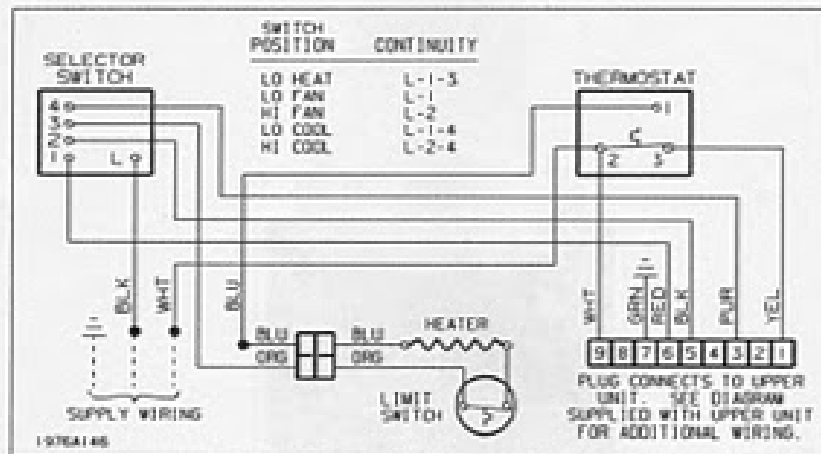

## WIRING DIAGRAM FOR 9000 SERIES ROOF MOUNT AIR CONDITIONERS

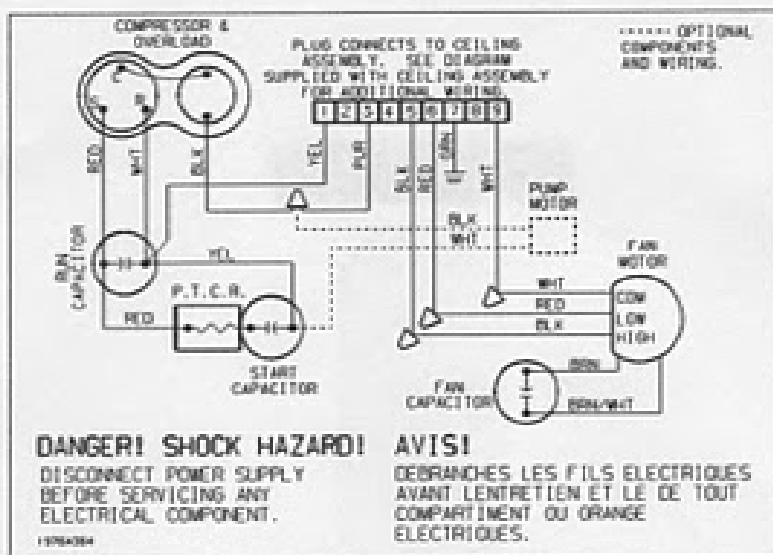

## WIRING DIAGRAM FOR 9330X715, 9330X716 HEAT/COOL CEILING ASSEMBLIES

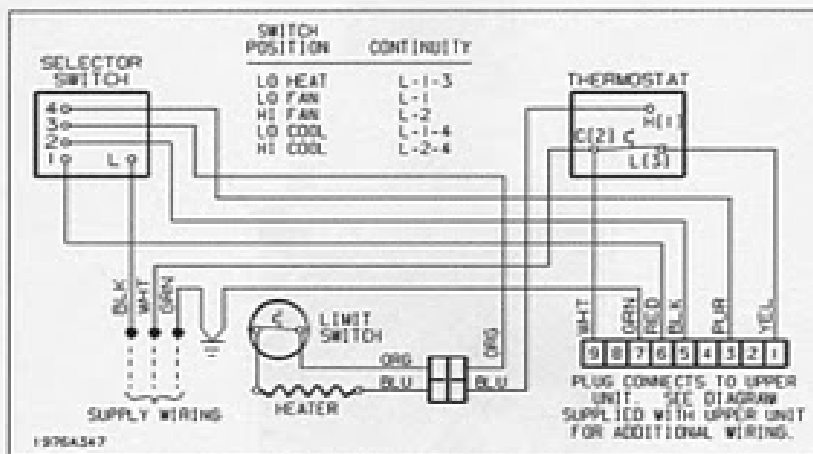



**WIRING DIAGRAM**  
**9330X713, 9330X714 COOL ONLY**  
**CEILING ASSEMBLIES**

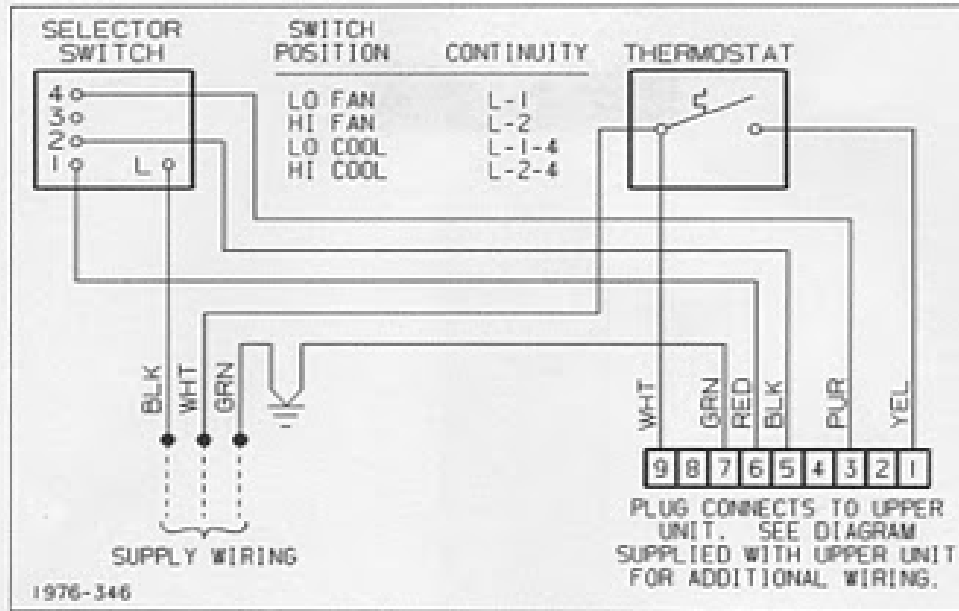



**RV Products**  
A Division of Aircel, Inc.  
P. O. Box 4020  
Wichita, KS 67204

1976F141 (12-03)